

INSTRUCTIONS

TANDEM UNI - DRILL

DP400A / DP600A



PLEASE READ CAREFULLY BEFORE USING THE MACHINE

June 2005 stdpa version 2.0

Dear Customer

Thank you for trusting our equipment and choosing the Tandem UNIDRILL.

To ENSURE correct operation, and make full use of your seed drill's capabilities, we recommend that you read this operators manual carefully.

Please do not hesitate to make suggestions or comments based on your experience; they will always be of use to us, and will help us improve our products.

Please return the duly completed guarantee form to us.

We wish you success with your seed drill.

Yours sincerely

Sam Moore
Managing Director

Guarantee Form



Drill Limited

33 Kirk Road , Ballymoney,
Co. Antrim , N. Ireland, BT53 6PP
Tel : +44(0)28276 64444
Fax +44(0)28276 65696

Machine Width: _____

Serial Number: _____

Customer Name: _____

Address: _____

Tel: _____

Mobile No: _____

E. mail : _____

Post Code : _____

I HAVE RECEIVED THE ABOVE MACHINE IN AN ACCEPTIBLE CONDITION AND TO THE CORRECT SPECIFICATION.

I HAVE RECEIVED AND READ THE OWNERS MANUAL FOR SAFE AND CORRECT OPERATION OF MACHINE.

I WISH TO REGISTER MY MACHINE FOR WARRANTY

SIGNED :- _____

CUSTOMER

DATE : - _____

1. To be completed, detached and returned to Moore Uni Drill within 14 days of customer receipt / purchase.
2. It is essential that all details be completed.
3. Failure to complete and return this form will prevent claim settlement

Declaration of Conformity

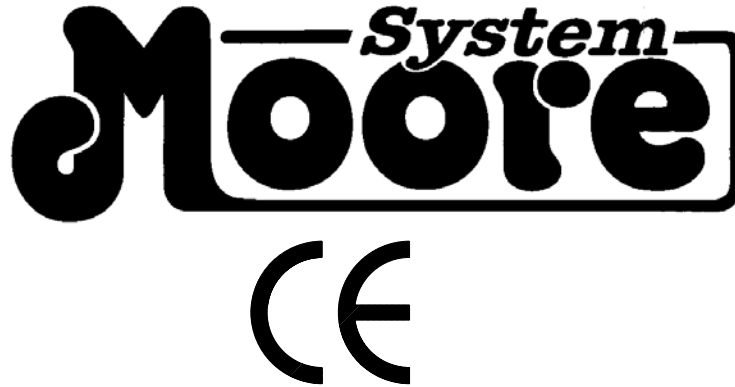

Declaration of Conformity

Moore Uni Drill Limited,

Of 33 Kirk Road, Ballymoney, Co. Antrim, N. Ireland. BT53 6PP

hereby declare that

Model

Serial No

Date

conforms with the following Directives and Regulations, and has been certified accordingly.

The Essential Health and Safety Regulations Directive. 98 – 37 - EC

The Proposed Seed Drills Safety Document 2000
(00/714171 DC)

Certified on behalf of Moore Uni - Drill Limited

James A O' Kane

Technical Engineer

Safety Regulations



Risk of accident



Risk of damage to the machine

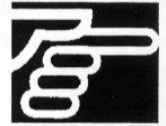

Operating tip

- These symbols are used in these instructions every time recommendations are provided concerning your safety, the safety of others or the correct operation of the machine.
- These recommendations must be given to all users of the machine.

GENERAL SAFETY REGULATIONS

Every time the tractor/machine assembly is to be started up and used, you should ensure beforehand that it complies with current legislation on safety at work and Road Traffic regulations.

GENERAL

1 - In addition to the instructions contained in this manual, legislation relating to safety instructions and accident prevention should be complied with.

2 - Warnings affixed to the machine give indications regarding safety measures to be observed and help to avoid accidents.

3 - When traveling on public roads, abide by the provisions of the Highway Code.

4 - Before starting work, it is essential that the user is familiar with the control and operating elements of the machine and their respective functions. When the machine is running, it may be too late.

5 - The user should avoid wearing loose clothing, which may be caught up, in the moving parts.

6 - We recommend using a tractor with a safety cab or roll bar conforming to standards in force.

7 - Before starting up the machine and beginning work, check the immediate

surroundings, particularly for children. Make sure that visibility is adequate. Clear any persons or animals out of the danger zone.

8 - It is strictly forbidden to transport any persons or animals on board the machine whether it is in operation or not.

9 - The machine should only be coupled up to the tractor at the specially provided towing points and in accordance with applicable safety standards.

10 - Extreme care must be taken when coupling or uncoupling the machine from the tractor.

11 - Before hitching up the machine, ensure that the front axle of the tractor is sufficiently weighted. Ballast weights should be fitted to the special supports in accordance with the instructions of the tractor manufacturer.

12 - Do not exceed the maximum axle weight or the gross vehicle weight rating.

13 - Do not exceed the maximum authorized dimensions for using public roads.

14 - Before entering a public road, ensure that the protective and signaling devices (lights, reflectors, etc) required by law are fitted and working properly.

15 - All remote controls (cords, cables, rods, hoses etc) must be positioned so that they cannot accidentally set off any manoeuvre, which may cause an accident or damage.

16 - Before entering a public road, place the machine in the

transport position, in accordance with the manufacturer's instructions.

17 - Never leave the driver's position whilst the tractor is running.

18 - The speed and the method of operation must always be adapted to the land, roads and paths. Avoid sudden changes of direction under all circumstances.

19 - Precision of the steering, tractor adhesion, road holding and effectiveness of the braking mechanism are influenced by factors such as the weight and nature of the machine being towed, the front axle stage and the state of the land or path. It is essential, therefore, that the appropriate care is taken for each situation.

20 - Take extra care when cornering, taking account of the overhang, length, height and weight of the machine or trailer being towed.

21 - Before using the machine, ensure that all protective devices are fitted and in good condition. Damaged protectors should be replaced immediately.

22 - Before using the machine, check that nuts and screws are tight, particularly those for attaching tools (discs, flickers, deflectors, etc). Tighten if necessary.

23 - Do not stand in the operating area of the machine.

24 - **Caution!** Be aware of any crushing and shearing zones on remote-controlled and particularly hydraulically controlled parts.

Safety Regulations

25 – Before climbing down from the tractor, or before any operation on the machine, turn off the engine; remove the key from the ignition and wait until all moving parts have come to a standstill.

26 – Do not stand between the tractor and the machine until the handbrake has been applied and/or the wheels have been wedged.

27 – Before any operation on the machine, ensure that it cannot be started up accidentally.

28 – Do not use the lifting ring to lift the machine when it is loaded.

PROPER USE OF THE MACHINE

The seed drill must only be used for tasks for which it has been designed. The manufacturer will not be liable for any damage caused by using the machine for applications other than those specified by the manufacturer. Using the machine for purposes other than those originally intended will be done so entirely at the user's risk. Proper use of the machine also implies:

- complying with instructions on use, care and maintenance provided by the manufacturer;
- using only original or manufacturer recommended spare parts, equipment and accessories.

The seed drill must only be operated, maintained and repaired by competent persons, familiar with the specifications and methods of operation of the machine. These persons must also be informed of the dangers to which they may be exposed.

The user must strictly abide by current legislation regarding:

- accident prevention
- safety at work (Health and Safety Regulations)
- transport on public roads (Road Traffic Regulations).

Strict compliance with warnings affixed to the machine is obligatory.

The owner of the equipment shall become liable for any damage resulting from alterations made to the machine by the user or any other person, without the prior written consent of the manufacturer.

HITCHING

1 – When hitching or unhitching the machine from the tractor, place the control lever of the hydraulic lift in such a position that the lifting mechanism cannot be activated accidentally.

2 – When hitching the machine to the three-point-lifting mechanism of the tractor, ensure that the diameters of the pins or gudgeons correspond to the diameter of the tractor ball joints.

3 – **Caution!** In the three-point lifting zone, there may be a danger of crushing and shearing

4 – Do not stand between the tractor and the machine whilst operating the external lift control lever.

5 – When in transport, lifting mechanism stabilizer bars must be fitted to the machine to avoid floating and side movement.

6 – When transporting the machine in the raised position, lock the lift control lever.

DRIVE EQUIPMENT

(Power take-off and universal drive shafts)

1 – Only use universal drive shafts supplied with the machine of recommended by the manufacturer.

2 – Power take-off and universal drive shaft guards must always be fitted and in good condition.

3 – Ensure that the tubes of the universal drive shafts are properly guarded, both in the working position and in the transport position.

4 – Before connecting or disconnecting a universal drive shaft, disengage the power take-off, turn off the engine and remove the key from the ignition.

5 – If the primary universal drive shaft is fitted with a torque limiter or a free wheel, these must be mounted on the machine power take-off.

6 – Always ensure that universal drive shafts are fitted and locked correctly.

7 – Always ensure that universal drive shaft guards are immobilized in rotation using the specially provided chains.

8 – Before engaging power take-off ensure that the speed selected

and the direction of rotation of the power take-off, comply with the manufacturer's instructions.

9 – Before engaging power take-off, ensure that no persons or animals are close to the machine.

10 – Disengage power take-off when the universal drive shaft angle limits laid down by the manufacturer are in danger of being exceeded.

11 – **Caution!** When power take-off has been disengaged, moving parts may continue to rotate for a few moments. Do not approach until they have reached a complete standstill.

12 – On removal from the machine, rest the universal drive shafts on the specially provided supports.

13 – After disconnecting the universal drive shafts from the power take-off, the protective cap should be fitted to the power take-off.

14 – Damaged power take-off and universal drive shaft guards must be replaced immediately.

HYDRAULIC CIRCUIT

1 – **Caution!** The hydraulic circuit is pressurized.

2 – When fitting hydraulic motors or cylinders, ensure that the circuits are connected correctly in accordance with the manufacturer's guidelines.

3 – Before fitting a hose to the tractor's hydraulic circuit, ensure that the tractor-side and machine-side circuits are not pressurized.

4 – The user of the machine is strongly recommended to identify the hydraulic couplings between the tractor and the machine in order to avoid wrong connection.

Caution! There is a danger of reversing the functions (for example: raise/lower).

5 – Check hydraulic hoses once a year, for:

- Damage to the outer surface
- Porosity of the outer surface
- Deformation with and without pressure

- State of the fittings and seals
The maximum working life for hoses is 6 years. When replacing them, ensure that only hoses with the specifications and grade recommended by the machine manufacturer are used.

Safety Regulations

6 – When a leak is found, all necessary precautions should be taken to avoid accidents.

7 – Pressurized liquid, particularly hydraulic circuit oil, may cause serious injury if it comes into contact with the skin. In the case of injury, consult a doctor immediately. There is a risk of infection.

8 – Before any operation on the hydraulic circuit, lower the machine, release the pressure from the circuit, turn off the engine and remove the key from the ignition.

MAINTENANCE

1 – Before commencing any maintenance, servicing or repair work, or before attempting to locate the source of a breakdown or fault, it is essential that the power take-off is disengaged, the engine turned off and the key removed from the ignition.

2 – Check regularly that nuts and screws are not loose. Tighten if necessary.

3 – Before carrying out maintenance work on a raised machine, prop it up using appropriate means of support.

4 – When replacing a working part (seed drill coulter or disc etc) wear protective gloves and only use appropriate tools.

5 – To protect the environment, it is forbidden to throw away oil, grease or filters of any kind. Give them to specialist recycling firms.

6 – Before operating on the electric circuit, disconnect the power source.

7 – Protective devices likely to be exposed to wear and tear should be checked regularly. Replace them immediately if they are damaged.

8 – Spare parts should comply with the standards and specifications laid down by the manufacturer. Only use Moore spare parts.

9 – Before commencing any electric welding work on the tractor or the towed machine, disconnect the alternator and battery cables.

10 – Repairs affecting parts under stress or pressure, (springs, pressure accumulators, etc) should be carried out by suitably qualified engineers with special tools

Danger

- A = Risk of crushing**
- B = Marker operating zone**
- C = Moving parts**
- D = Do not travel on the platform**
- E = Rotating agitator shaft**

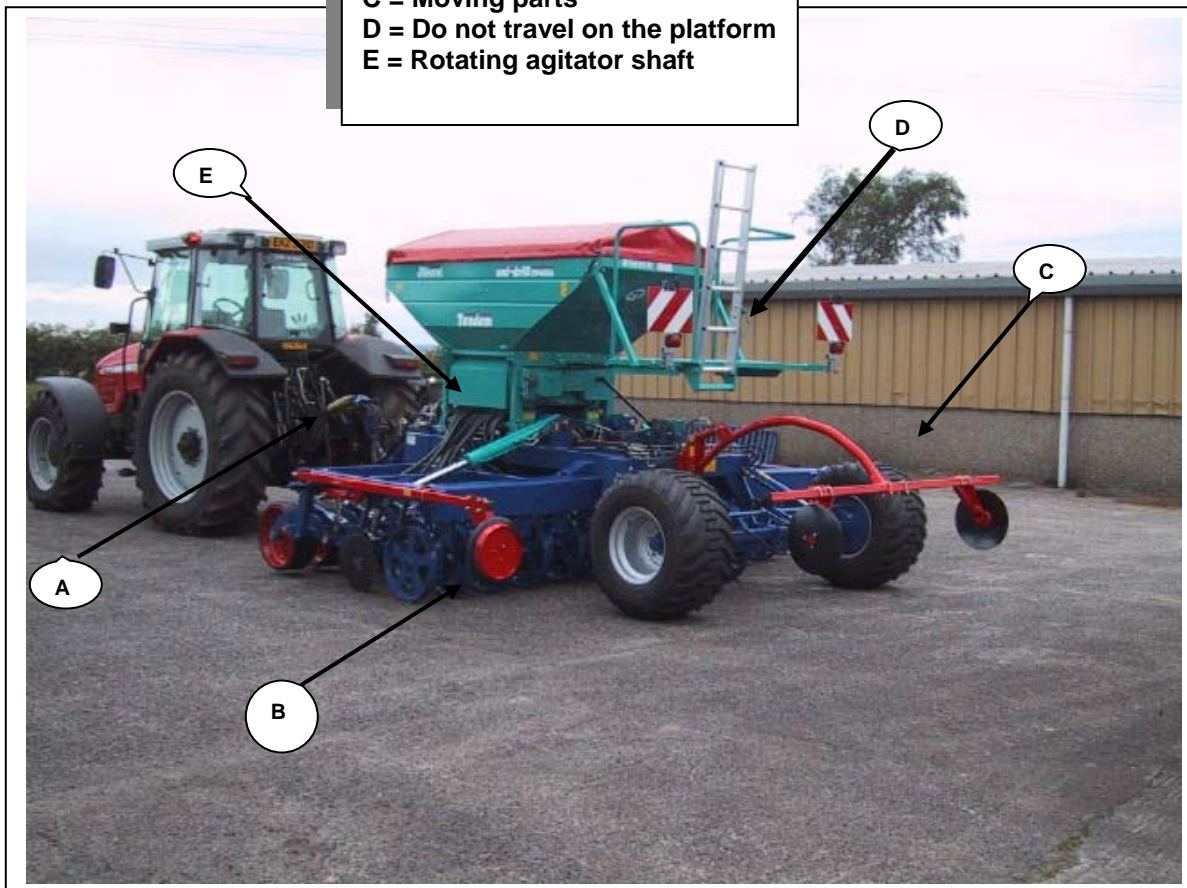

Safety Regulations

Safety Stickers

Warning notices relating to safety are affixed to your machine.

Their aim is to contribute to your safety and to the safety of others.

Know their contents and check their location.

Review the safety notices as well as the instructions contained in this operating manual.

If any safety notices become illegible or lost they should be replaced.

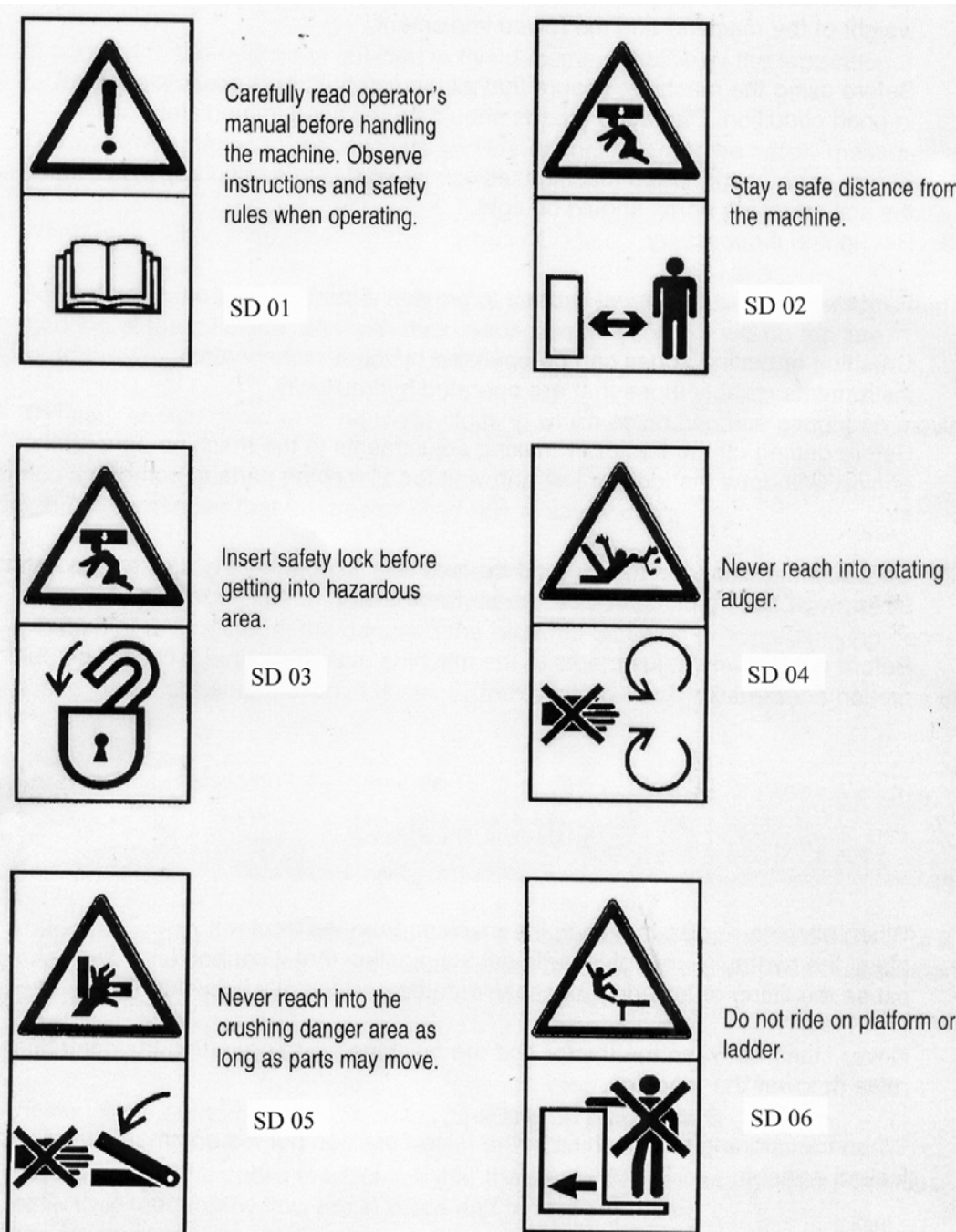

Safety Stickers

SD 07

Tighten implement wheel studs after the first 4 working hours and then daily thereafter

Ensure wheel nuts are tight

SD 08



DANGER
TRANSPORT PINS MUST BE USED BEFORE WORKING ON THE MACHINE WHILST IN THE RAISED POSITION

Ensure transport pins are used when working under raised machine

SD 09



Do not work under raised marker

SD 10

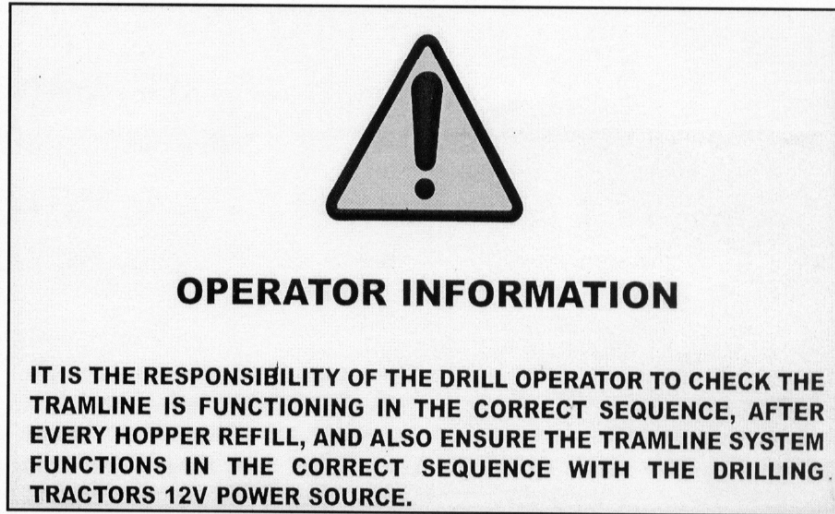

OPERATOR INFORMATION
IT IS THE RESPONSIBILITY OF THE DRILL OPERATOR TO CHECK THE TRAMLINE IS FUNCTIONING IN THE CORRECT SEQUENCE, AFTER EVERY HOPPER REFILL, AND ALSO ENSURE THE TRAMLINE SYSTEM FUNCTIONS IN THE CORRECT SEQUENCE WITH THE DRILLING TRACTORS 12V POWER SOURCE.

Ensure the tramline system is functioning correctly after each fill

SD 11

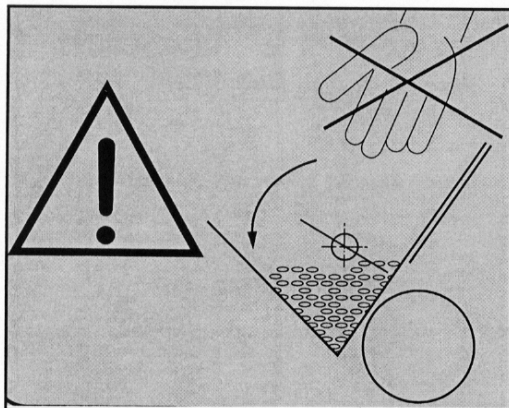

Never reach into rotating auger

SD 12

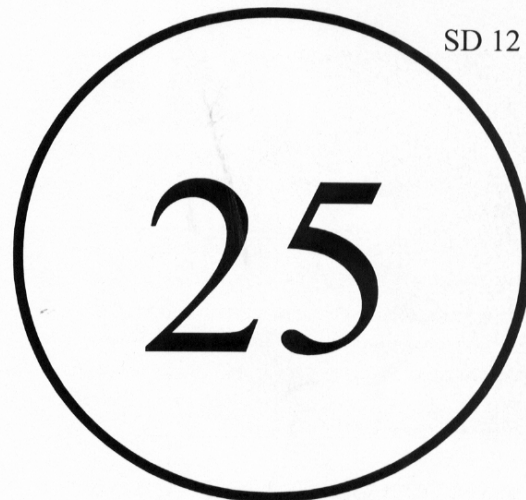

Forward speed should not exceed 25 KPH

Contents

Start Up

		Pages
A	Technical Specifications	11
B	Operator Check List	12
C	Hitching	13
D	Transport	14
E	Hydraulic Connections	15
F	Hopper Cover	16
G	Turbine	17 - 19

Settings

A	Distribution	20 - 25
B	Sowing Depth	26
C	Weight Transfer	27
D	Coulter Adjustment	28
E	Markers	29
F	Half Width Shut Off	30
G	Electronic Tramlines	31
H	Tramline Track Width	32

Maintenance

A	Wear Check	33
B	Seed Distribution	34
C	Greasing and Lubrication	35

Optional Equipment

A	Multiplier	36
B	Flexible Agitator	37
C	Pre Emergence Marker	38
D	Moore Headland Control	38-46

Practical Recommendations **47 – 48**

Flow Rate & Calibration Procedure **49 - 55**

Warranty **55 - 56**

A : Technical Specifications

When accepting ownership of your machine note the following information:

Serial Number: _____

Type of machine _____

Accessories: _____

MOORE UNIDRILL	DP400A	DP600A
Width (m)	4	6
Number of rows	24	36
Row spacing (cm)	16.6	16.6
Width in transport (m)	3	3
Hopper capacity (l)	1600	2200
Weight (Kg)	3750	5750
Horse Power Required (HP)	130	180

B : Operator Check list

It is the owner / drill operators responsibility to set up the drill for:

- 1. Sowing depth according to conditions in each soil type and pre worked condition**
- 2. Tramline bout number to suit tramlines**
- 3. Tramline track width**
- 4. Number of rows shut off whilst tram lining**
- 5. Marker width setting to allow matching of bouts**
- 6. Operation of half width shut off**
- 7. Folding the machine in and out of work without damage**

It is also the owner / operator's responsibility to check the operation of the various functions of the machine between each hopper fill, or at least once every hour to check the machine is operating correctly.

C : Hitching

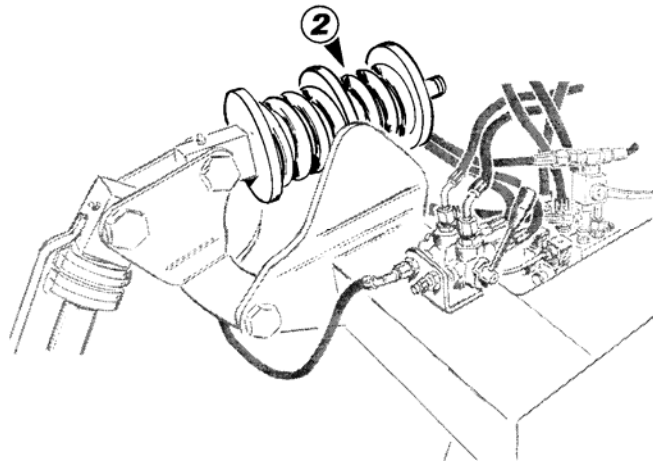
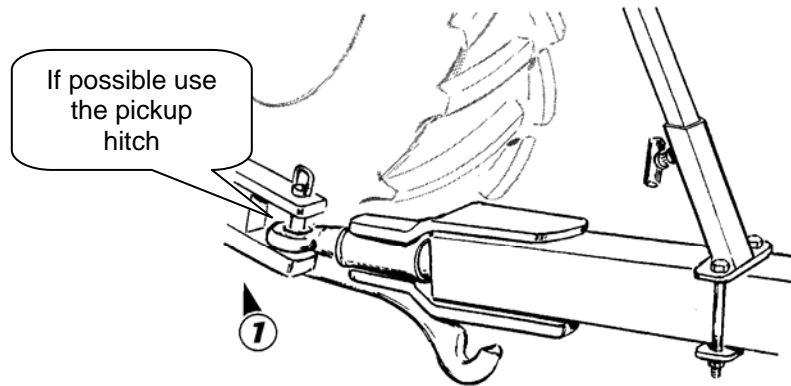

- To unhitch, set the machine with the transport wheels resting on the ground
- Beware of the drawbar motion

1 Hitching height

The height of the hitching point greatly influences the performance of the device (+/- 450 mm).

- The hitching point must be fixed.
- Low hitching heights should be preferred,
- The drawbar should be preferred when twin wheels or wide tyres are used, to make field-end manoeuvring easier.

2 Damper

- This was set in the factory

D : TRANSPORT

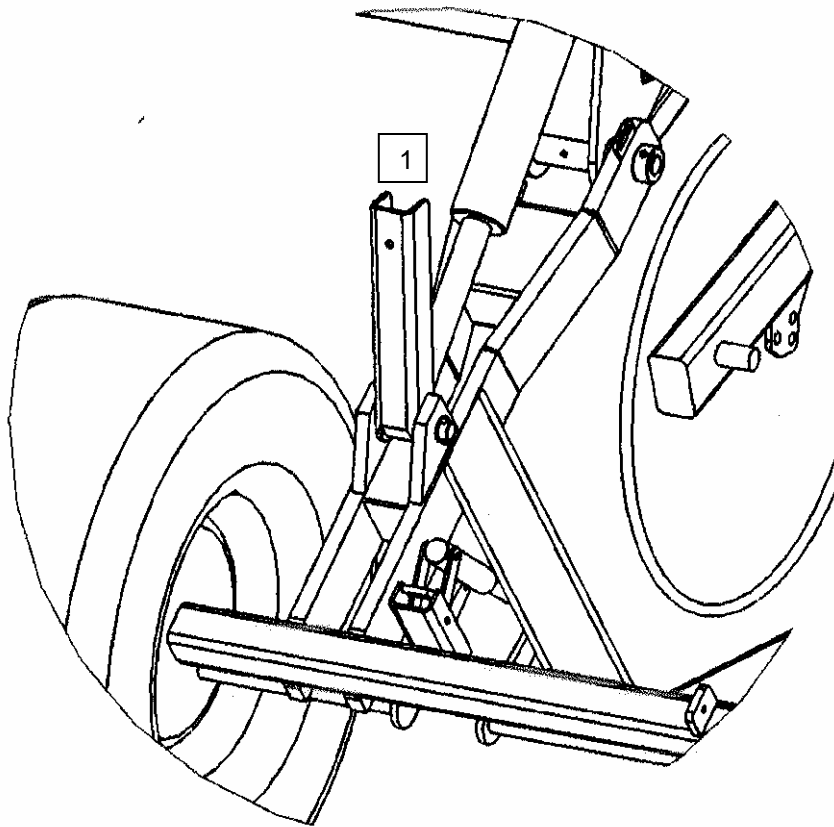

Users must scrupulously observe traffic regulations on open roads.

Travel only with an empty hopper.

Users must also use the transport pins when making adjustments to the drill

Important: Do not exceed 25 Kilometers per hour **TRANSPORT SPEED**

TRANSPORT

- Positioning the transport locks (1)
 - Raise the seed drill
 - Insert the transport locks
 - Lower the machine to rest mandatorily on transport locks

Do not stand near the axle during operation

E : HYDRAULIC CONNECTIONS

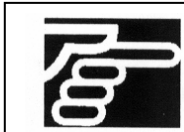
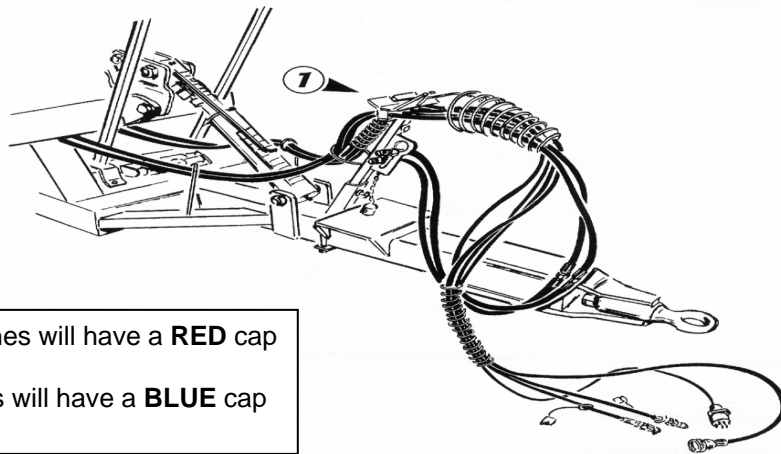

Pressure lines will have a **RED** cap
Return lines will have a **BLUE** cap

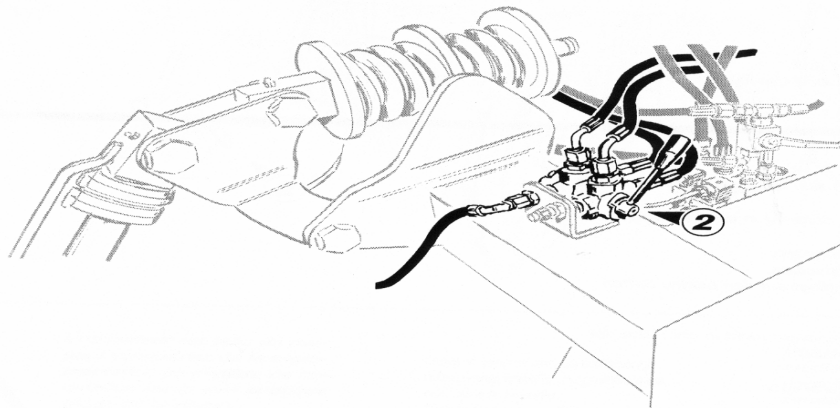

Hydraulic connections

- 1 Double-action spool valve to operate valve block
- 1 Motor spool valve for hydraulic fan, c/w free flow back to tractor
- 1 hydraulic brake connection



When folding the machine in and out of work, park the tractor and drill on a level surface, lift the drill fully on the front and rear, insert the transport pins and then fold/unfold the drill with extreme caution.

F : HOPPER COVER

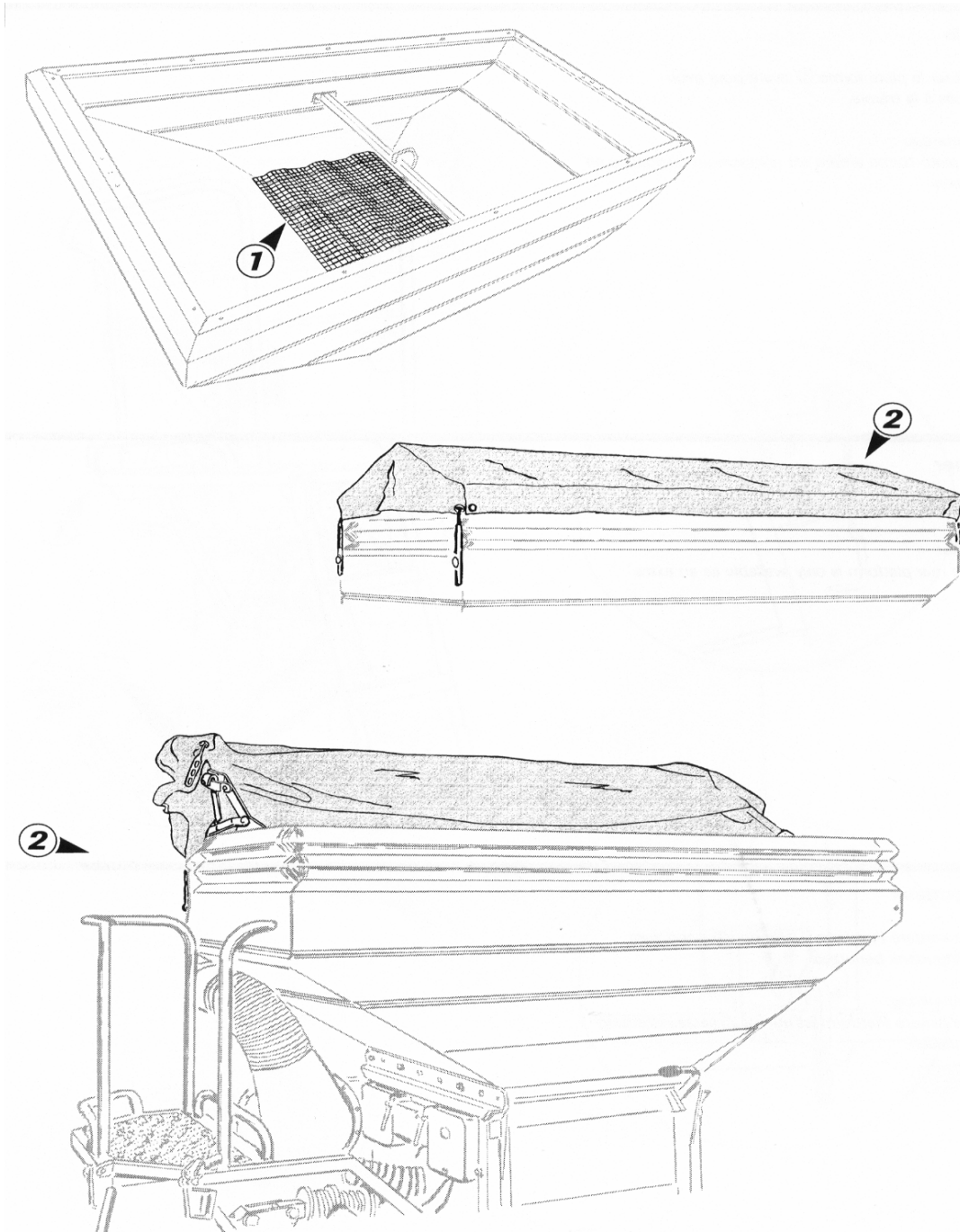

- Ensure that sieve (1) is in place in the bottom of the hopper bottom.
 - Operate with tarpaulin (2) sealed.

G : TURBINE

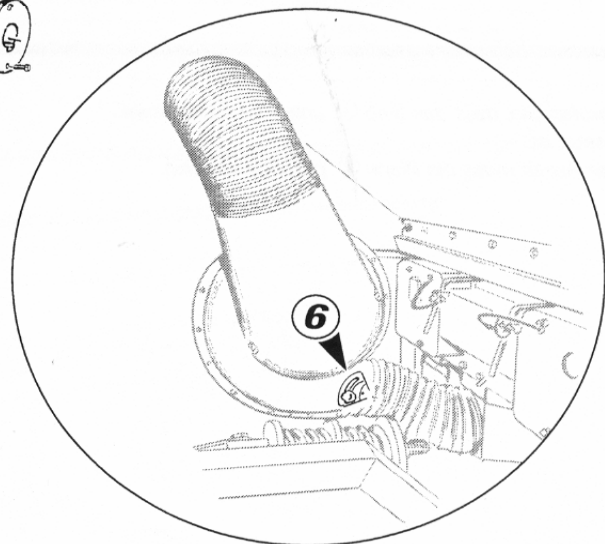
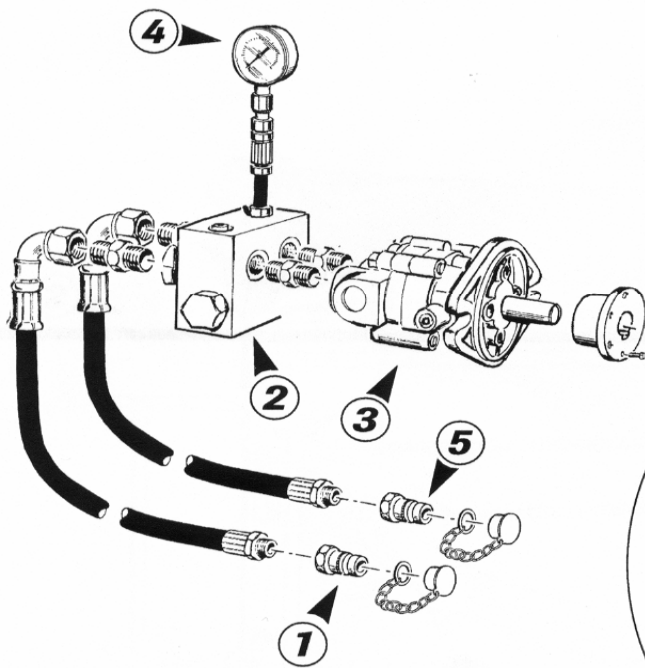
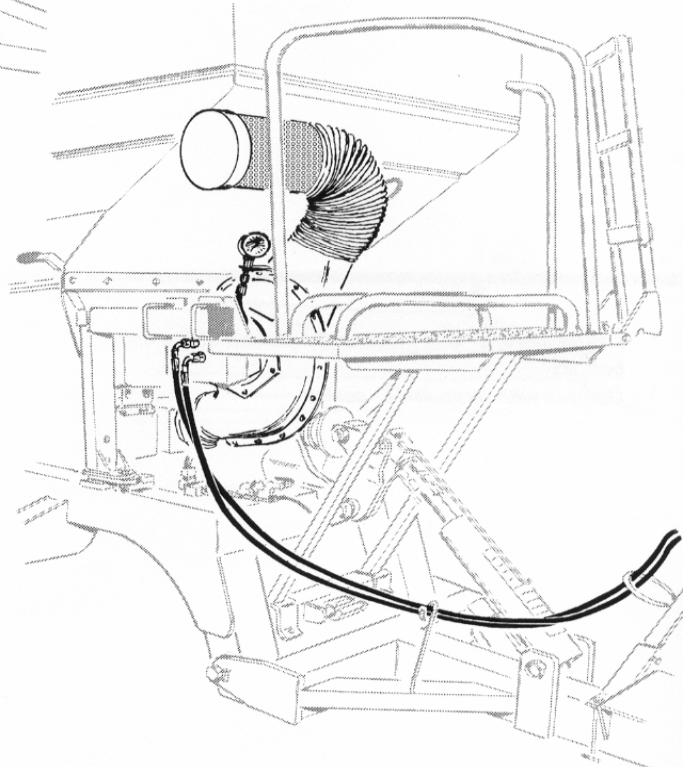
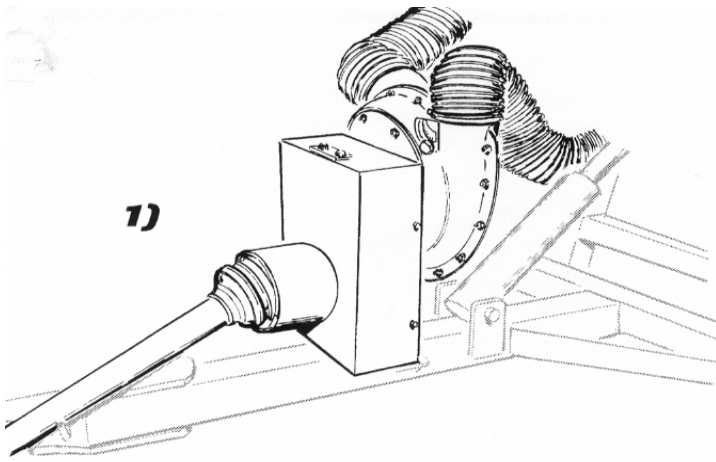

Start Up

G : Turbine – Operating Instructions

1) Mechanical

- Use the 1000 RPM power take-off
- Maintain tractor engine rate during work
- Do not engage the PTO on full load

2) Hydraulic

a) Specification

Warning and reminder: a number of checks need to be made on the tractor when using the hydraulic turbine drive system. Consult your dealer.

- 1) The minimum oil flow rate required at working RPM is 30 liters/min
- 2) The oil pressure rises to 180 bars on start-up
- 3) **Feedback must imperatively be below 15 bar; otherwise extensive damage will be caused to the hydraulic motor. If possible always try to run the oil back into the tractor, without any restriction, i.e. put the return pipe for the hydraulic fan motor directly into the back of the tractor without going through the spool valve.**
- 4) When using a tractor with open center hydraulics, use the oil flow regulator on the tractor to control the speed of the fan and **free flow the oil back to tank**. If there is no flow regulator on the tractor, an inline flow regulator will be required for the motor, again free flow back to tank.
- 5) When using a tractor with closed center hydraulics (John Deere) use a Series 3 SCV valve (motor Spool). If this is not fitted refer to your John Deere Dealer
- 6) When using the spool lever to control the hydraulic fan consider the points listed below.
 1. Engage the fan N to P
 2. Disengage the fan P to F
 3. To get the tractor back to N stop the engine and return manually.

Key: T = Tank
N = Neutral
P = Pressure
F = Float

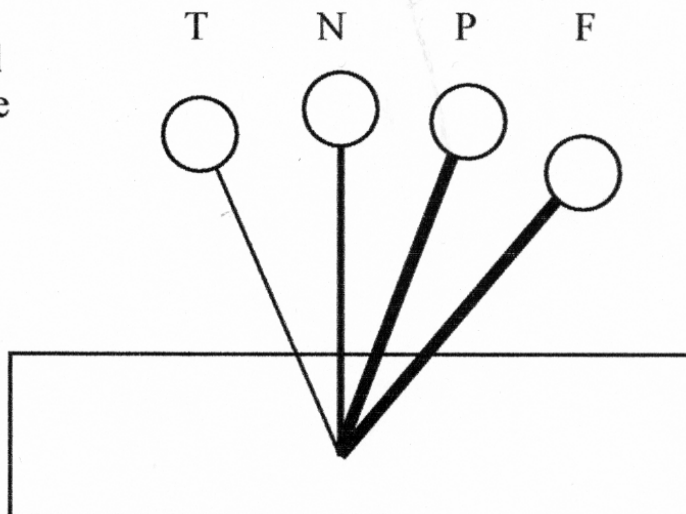

Failure to disengage the fan through the float facility on the spool lever, will 'dead head' the hydraulic motor, this may then destroy the manometer or damage the fan motor seals.

Start Up

G : TURBINE – Operating Instructions

- 7) Always clean the hydraulic connection correctly
- 8) When putting into service for the first time, the number of revolutions must be corrected between start-up (cold oil) and normal operation (warm oil)
The turbine speed is checked on the Moore Tronic unit.
- 9) Tractor connection
 - The fan rate can be adjusted with the tractor-metering device regulating valve.

b) Description of operation

- (1) Intake with Push Pull connector (red plug on rubber strap)
- (2) Divider unit
- (3) Motor
- (4) Pressure gauge on hydraulic feedback (< 15 bar)
- (5) Free feedback hose (blue plug on rubber strap)

c) Using the hydraulically-driven turbine

- Adjusting air flow rate
 - Using the tractor oil rate control valve, adjust the rotation to a rate between 3300 and 3600 rpm max
 - Depending on the type of seed: operate the air baffle (6) to adjust air flow
 - 5 settings are available depending on the type of seeds

Mark No :

1. .
2. .
3. Linseed, Ryegrass, Rape, Lucern
4. Wheat, Barley
5. Peas, Field Beans

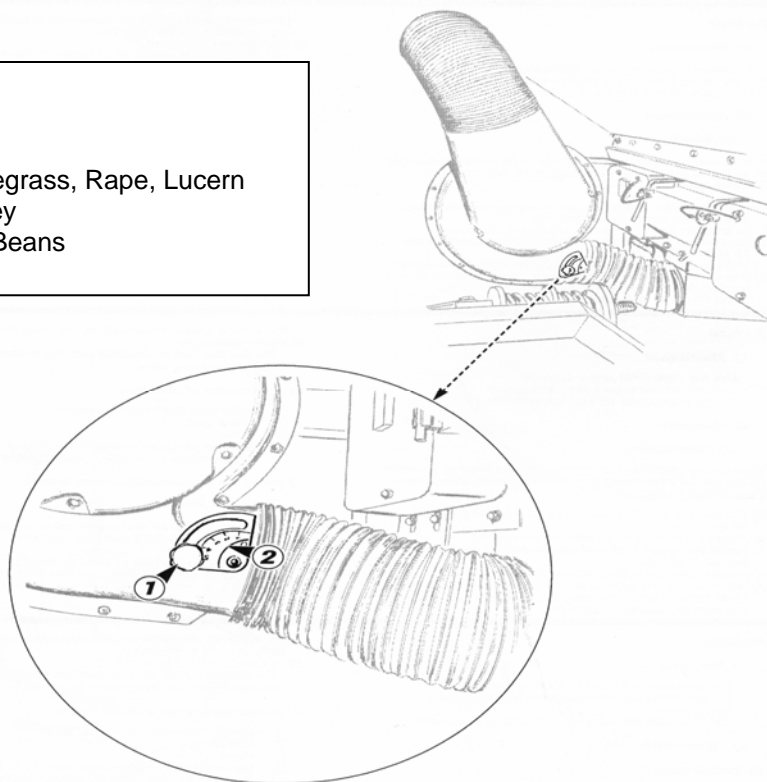

A : Distribution Settings

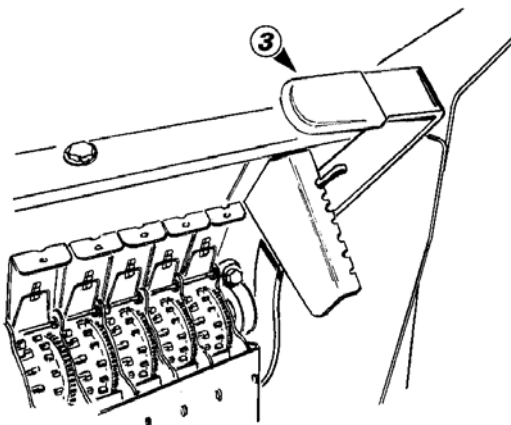
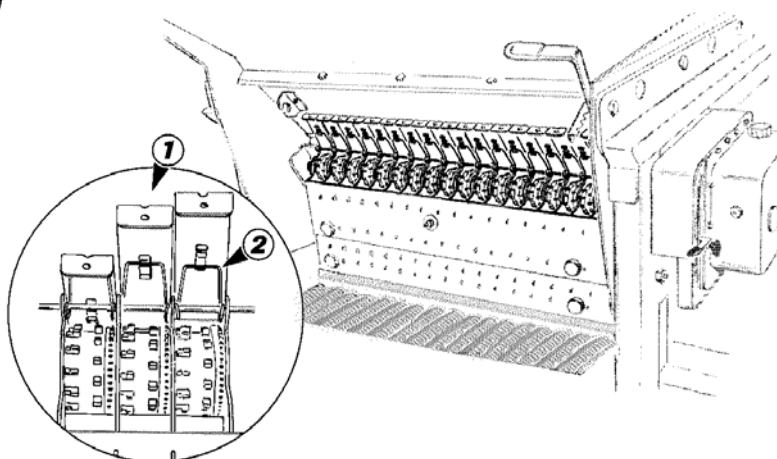

FOLLOW SETTING INSTRUCTIONS

1) Distribution shutter

- Raise or lower shutter (1) according to recommendations.

2) Clip spring (2) in the corresponding notch

- It is a three-position shutter
- Index
 - 0) Closed (e.g. sowing every other row)
 - 1) Small seed <8 kg/ha
 - 2) Large seed

3) Flap

- Move lever (3) slightly to the right and set it to the corresponding notch
- Index
 - 1 Cereals
 - 2
 - 3
 - 4 Preserve peas
 - 5 Peas
 - 6 Field beans
- Max Low position, Hopper emptying
- Seek to lead the seed with the peg wheel while tightening the flap as much as possible (e.g. index 1 for wheat, barley).
However if seeds are continually being projected, set the lever one notch higher than recommendations (e.g. index 2 for wheat, barley).

A: Distribution Settings

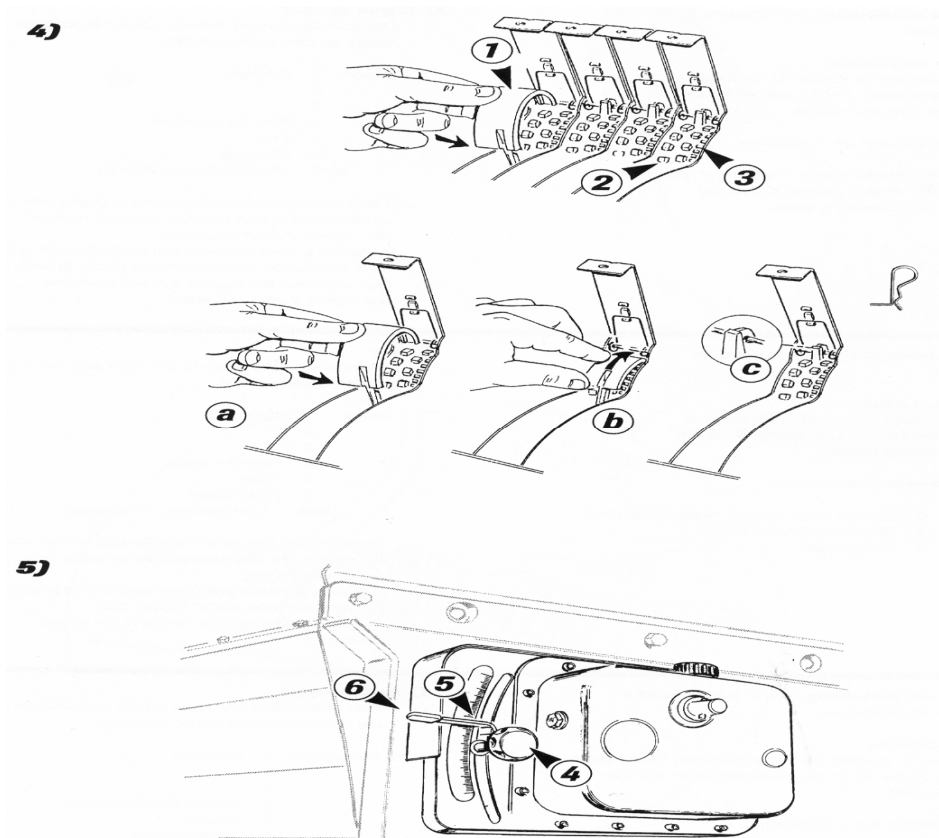

Follow setting instructions. Store rape shutters in a dry place and away from any deterioration risks

4) Selecting the peg wheel

- Rape Shutter fitting is to be carried out:
 - with the hopper empty
 - shutters to position 2
 - flaps to maximum opening position
 - a) Engage plug (1) on the peg wheel so as to cover it
 - b) Rotate
 - c) Engage the spring pin
 - d) Set the flaps to position 1
- Dismantling is done by reversing the procedure
- Use pin B to unclip
- Index
 - Standard peg (2) (large seed/cereals)
 - Fine peg wheel (3) rate < 8 kg/ha

5) Variator

- Set the flow rate trial index using knurled wheel (4), and lever
- Read values above the flat plate (5)
- Each index change must be followed by a flow rate test. For information 3 vernier grades correspond to about 10 kg/ha of cereals
- Index from 0 to 90

Settings

A : Distribution Settings

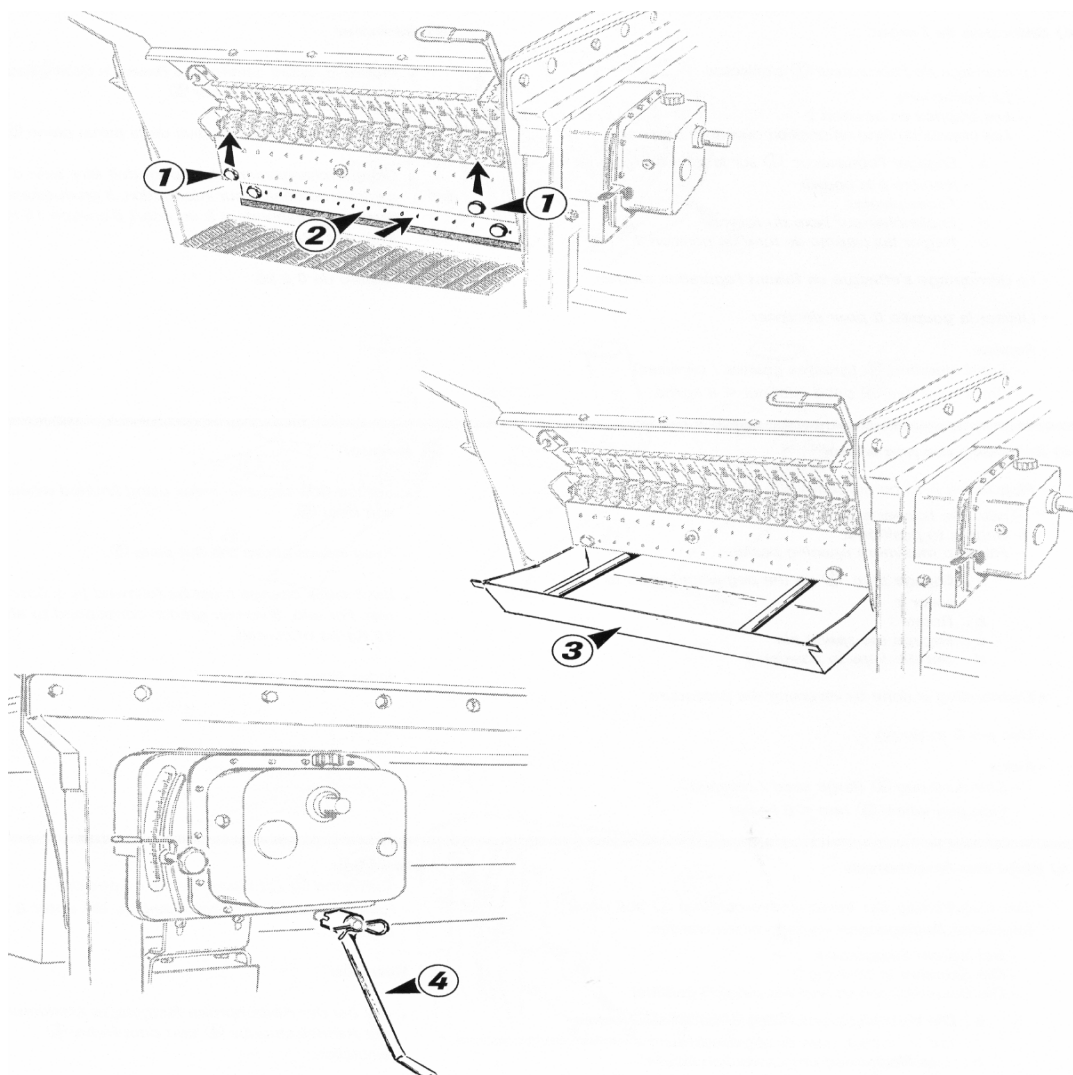

For very accurate sowing, a flow rate test must be carried out. Check the precision of your scales.

Setting up the calibration test

- Use accurate scales and a container.
- Before carrying out the test, check that there is no-one around the seed drill.
- Procedure:
 - a) Remove the wheels (1)
 - b) Push the injectors (2)
 - c) Put the trough (3) beneath the metering device
 - d) Fit the crank (4) on to the variator shaft
- Check that the metering devices used are engaged.
- Perform the flow rate test with both trays and according to the recommendations of the following pages.
- Close the injectors.
- Bring the trough back to the guard position.
- **NOTE:** It is possible to do the test on one side only by disengaging the left half-distribution system. The amount of seed collected in kg will have to be doubled.

Settings

A : Distribution Settings

1

Colza			
Rape	1	1	2
Raps			
Luxerne			
Lucern	1	1	1
Lucerne			
Ray grass			
Rye grass	1	1	1
Gras			
Blé			
Wheat	2	1	1
Welzen			
Orge			
Barley	2	1	1
Gerste			
Pois			
Pees	2	5	1
Erbisen			

5

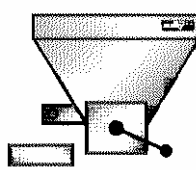

1 tr / s

m	2,50	3,00	3,50	4,00	4,50	4,80	5,00	6,00	6,66
tr	60	80	43	37,5	33,3	31,25	30	25	22,5

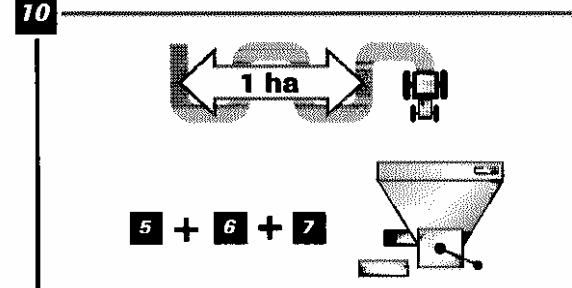
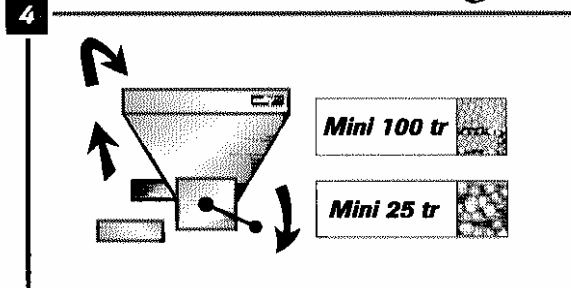
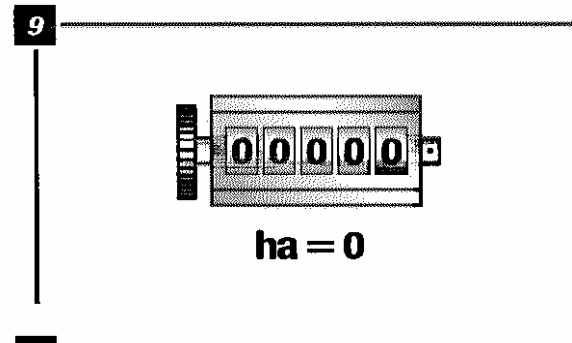
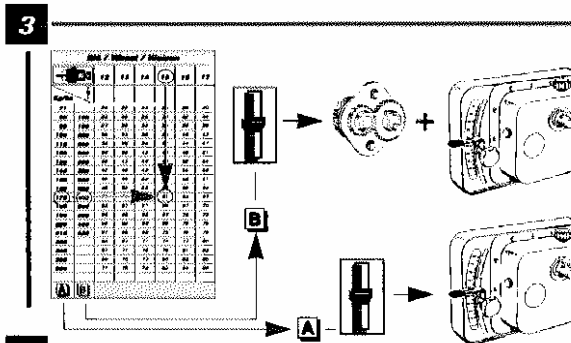
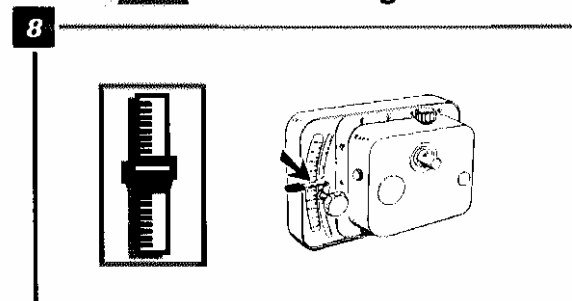
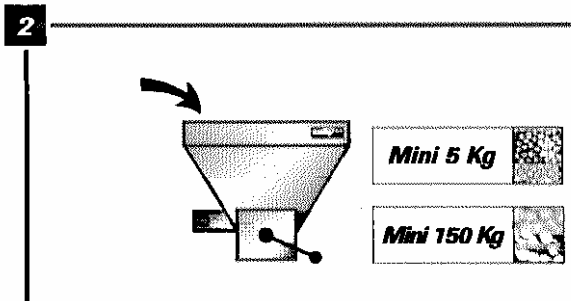
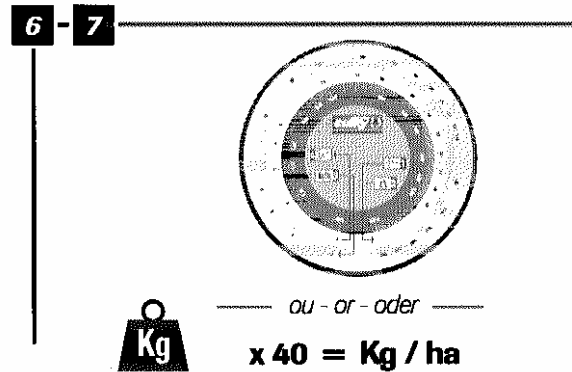

Settings

A: Distribution Settings

Carrying out the calibration test

1) Fixed unit test

- 1 Set the distribution as indicated in the manual (plugs, baffle, plate, shutters etc.).
- 2 Put the grain in the seed box **on the day of sowing** (5 kg of rape, 150 kg of cereal) and carry out the following test.
- 3 **Set** the variator to the mark indicated in the table (see flow rate table and calibration).
- 4 **Start** distribution: a **minimum of 25 turns** of the crank (the trough may be filled), or **100 turns** for rape.
- 5 **Carry out** the test by completing the appropriate number of turns for the width of the seed drill. **N B** Turn steadily at **1 turn per second**.
- 6 **Weigh** the quantity collected in the trough using accurate scales.
- 7 **Multiply by 40** to obtain the quantity per hectare or use the calculator (see next page).
- 8 **Correct** the variator setting (lower the lever completely then bring it back up to the required value).
- 9 **Reset** the area meter to zero after the calibration test.
- 10 The most representative test is one carried out under real working conditions.

After sowing a hectare, carry out a further check (proceed as above from step 5).

Checking the distribution system

Distribution of seed to the seed tubes should be checked at regular intervals through out the day, for example every hour.

- Check both sides of the drill appear to be delivering the same amount of seed to each coulter.
- Manually turn the drive wheel with the fan running to ensure seed is blown out of each coulter.
- Engage tramline mechanism and repeat the above procedure, Note the voltage the tramline system receives from the tractor affects the way in which the tramline will work, **IF THE TRACTOR IS SUPPLING AN INVERSE POLARITY VOTAGE TO THE TRAMLINER, THE TRAMLINER MECHANISM WILL WORK IN THE OPPOSITE MANNER ,i.e TRAMLINER WHEN IT SHOULD'NT AND NOT TRAMLINER WHEN IT SHOULD**
- When calibrating the seed box check each side of the drill is delivering the right amount of seed.

Settings

A : Distribution Settings

SLIDE RULER

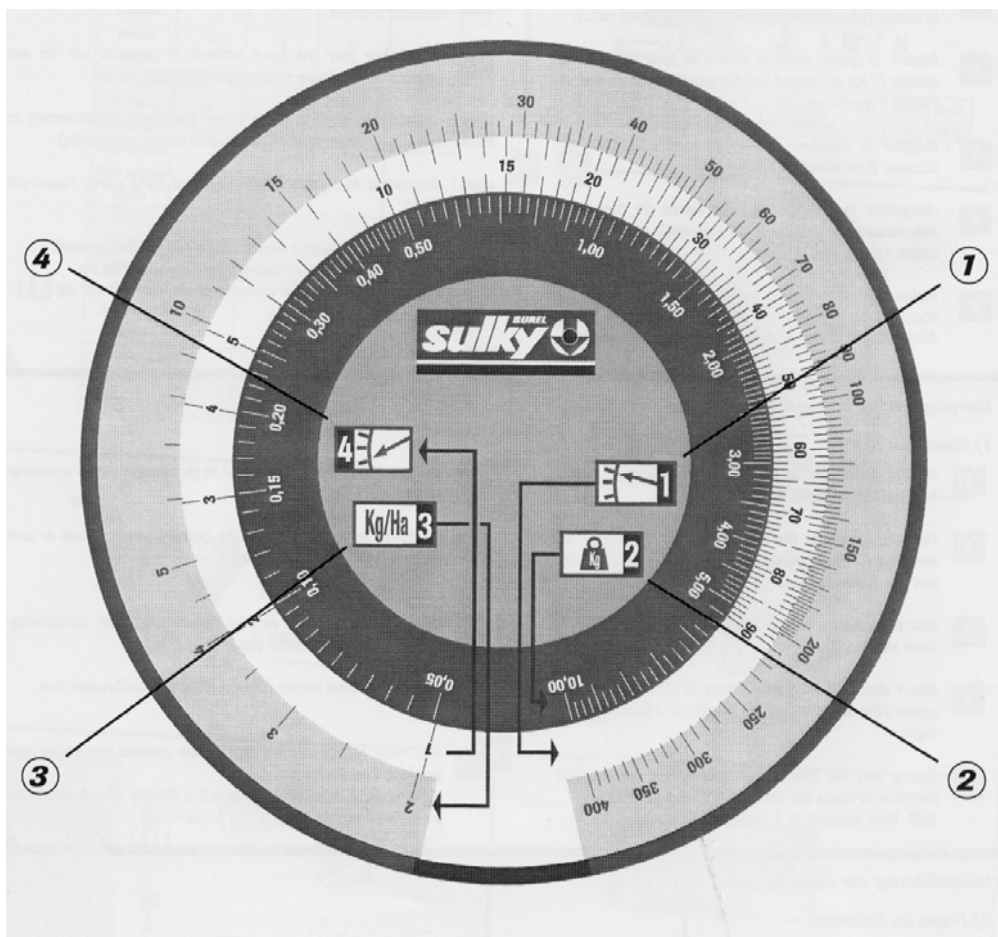

Test using the slide ruler

- This slide ruler enables you to determine the new variator index after the first flow rate test.
- Adjust distribution settings and carry out a test according to the recommendations contained in the preceding pages.
- Operation:
 - Set line (1) of the variator index used for the first flow rate test on line (2), which corresponds to the amount in kg collected in the tray during that test
 - Without moving the slide ruler discs, find the target flow rate in Kg/ha on the line (3)
 - On line (4), read the new variator index corresponding to your seed and conditions
- After sowing one hectare, perform another verification test.
- If you want to change the rate/ha with the same seed but on another plot, use the slide ruler to determine the new variator index from the weight value of the first flow rate test.

Settings

B : Sowing Depth

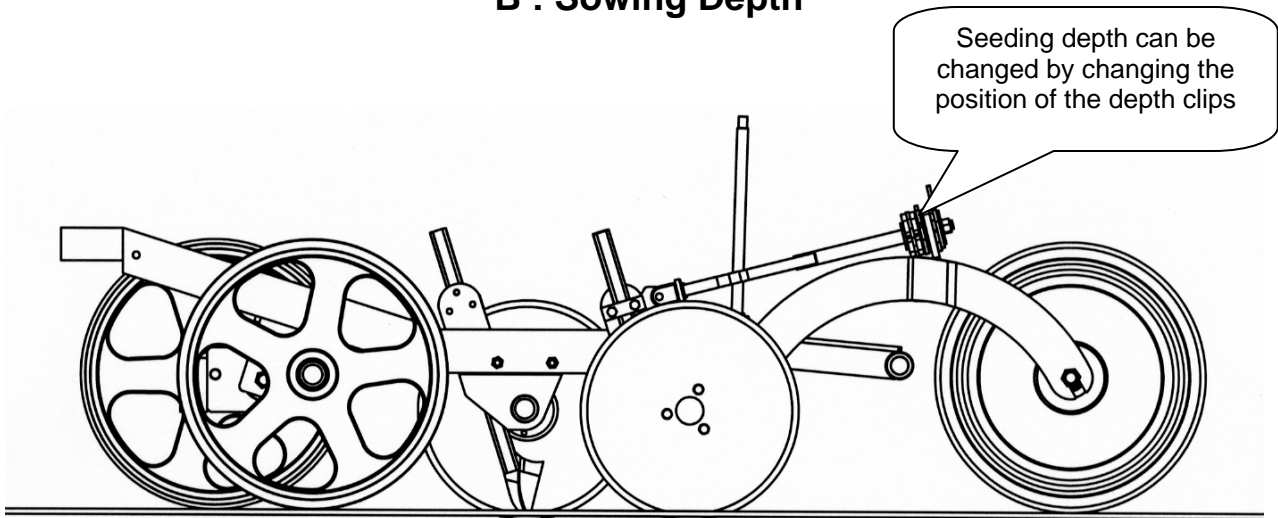

By moving depth clips from the 'A' side to the 'B' side and vice versa the seeding depth can be adjusted

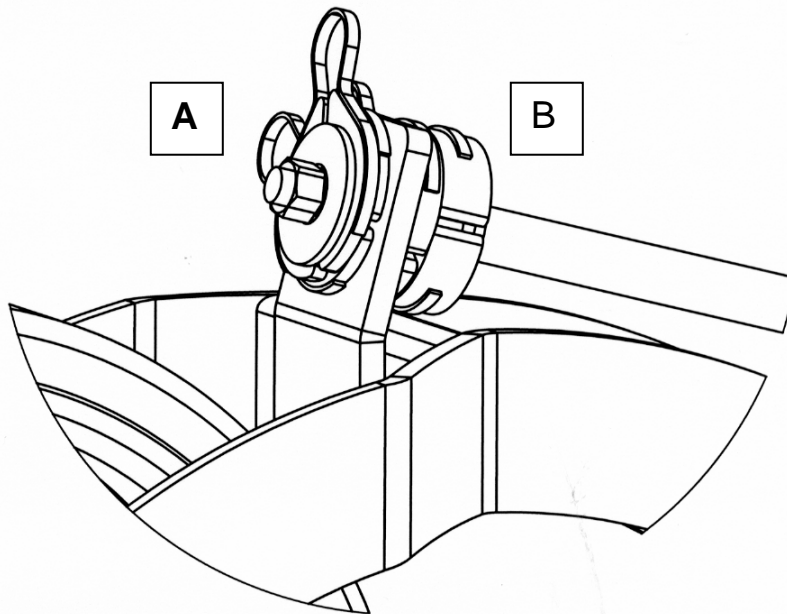

The table on the right shows how it is possible to get a range of depth stages from the depth clips

'A' side	'B' side	Depth stage
1/4", 1/4" 1/2", 1"		1 (Deep Sowing)
1/4", 1/2", 1"	1/4"	2
1/2", 1"	1/4", 1/4"	3
1/4", 1"	1/2", 1/4"	4
1"	1/4", 1/4", 1/2"	5
1/4", 1/2"	1/4", 1"	6
1/4", 1/4"	1", 1/2"	7
1/4",	1/4", 1/2", 1"	8
	1/4", 1/4", 1/2", 1"	9 (Shallow Sowing)

The sowing depth should be checked regularly throughout the day, for example every 4 hectares. Check sowing depth midway between tractor tracks, within a tractor track and at each side of the seed drill.

C : Weight Transfer

Using the front ram, it is possible to transfer weight, onto the front or rear press wheels, this is done by inserting stroke control segments onto the front ram to limit its stroke.

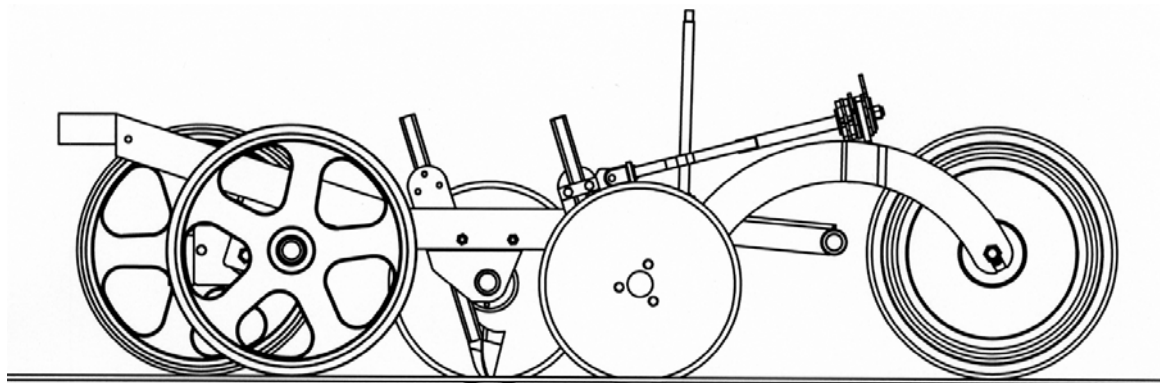
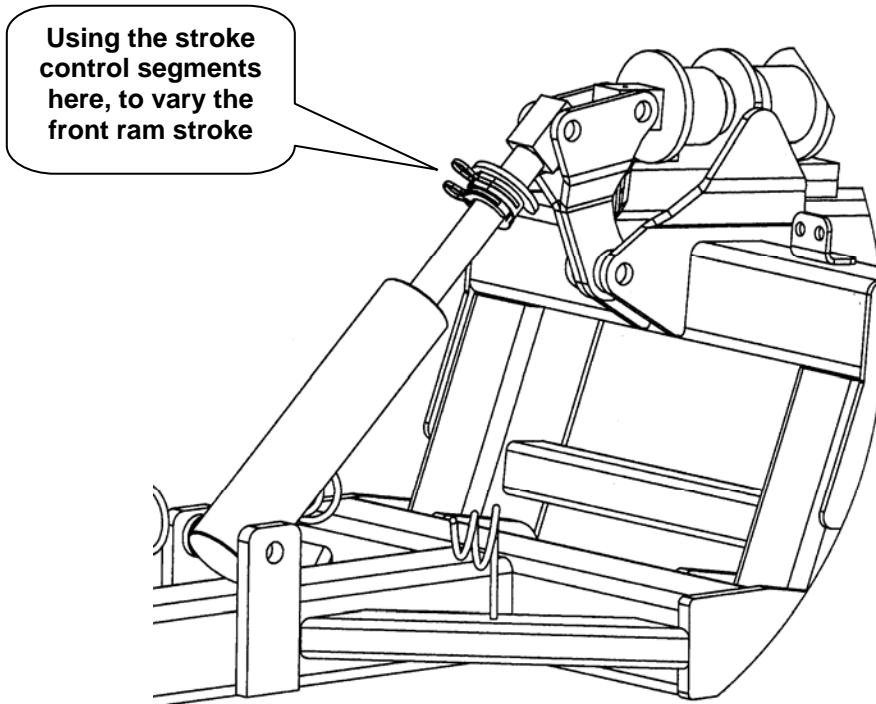

Using the stroke control clips to limit retraction of the front ram, will increase the weight transferred onto the rear press wheel and reduce the weight on the front press wheel

Using the stroke control clips to allow retraction of the front ram, will increase the weight transferred to the front press wheel and reduce the weight on the rear press wheel

D : COULTER ADJUSTMENT

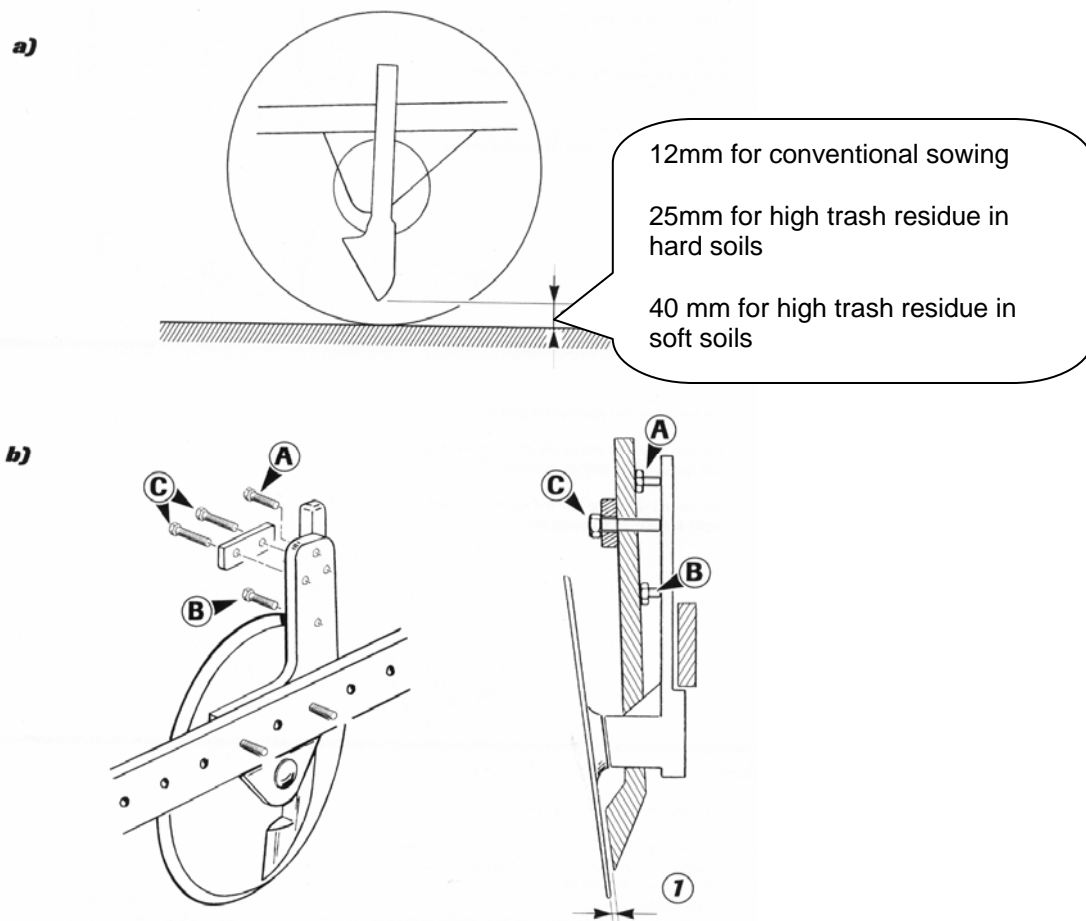

Coulters adjustment

a) Adjusting coulters height:

The tip of the coulters is approximately 20 mm above the disc edge for drilling in high trash volumes, it should be set 12mm above the disc edge, when being used in conventional seed beds.

- This is the minimum clearance that must imperatively be observed to protect the coulters from impacts
- Adjusting that clearance is easy, the machine being set on a flat and level area with a block under the coulters

Note: When operated on very soft soil encumbered by trash, it is recommended to raise the coulters to 40 mm above the disc edge to facilitate disc motion.

b) Recline adjustment:

The coulters (1) leading edge should be:

- Parallel to the disc
- As close as possible to the disc but not hampering its rotation

Should the discs jam, coulters adjustment is necessary. Use screws A and B to set the coulters closer to or further from the disc.

Ensure that the coulters leading edge is parallel to the disc:

- Use C screws to adjust parallelism by swiveling the coulters around A and B screws

E : Markers

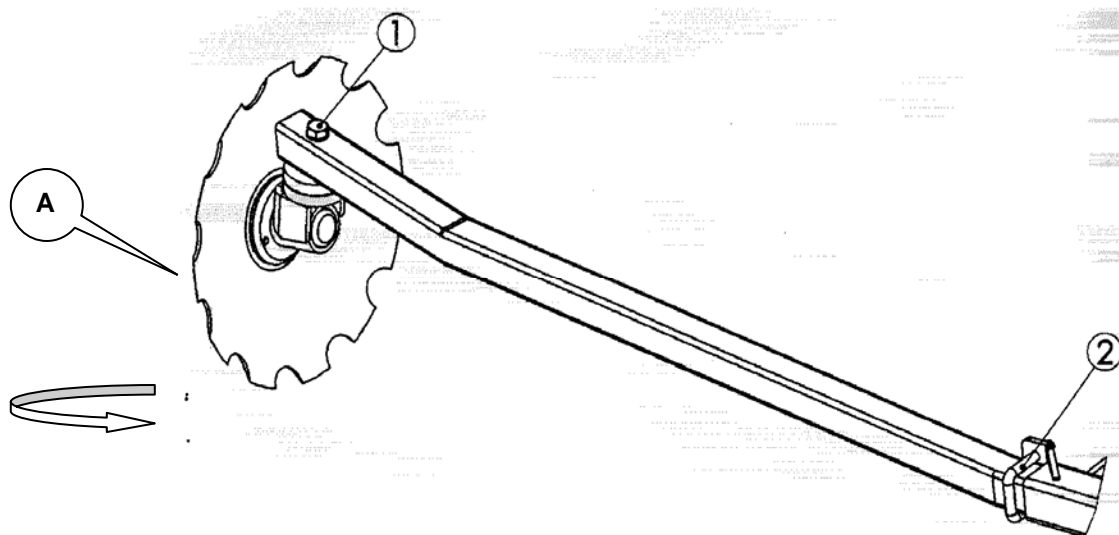

Setting Markers to working position

Markers are designed for marking the tractor centerline.

Markers are pre-adjusted in the factory, but they need to be checked in the field, if adjustment is required move the disc bracket (A) along the tube. This can be done by slackening the U bolt (2)

The distance between the first sowing row and the marker disc equals $\frac{1}{2}$ sowing width plus $\frac{1}{2}$ the seed row spacing.

The disc angle can be changed by loosening bolt (1) and increasing the disc angle to get the desired marking intensity.

Operation of markers using Moore headland Control

See page 46 for operation of markers on the Moore Headland control



The markers should be operated in a gentle manner, beware of obstacles when drilling, turning at the headlands should be carried out with the markers in the home position

F : Half Width Shut off

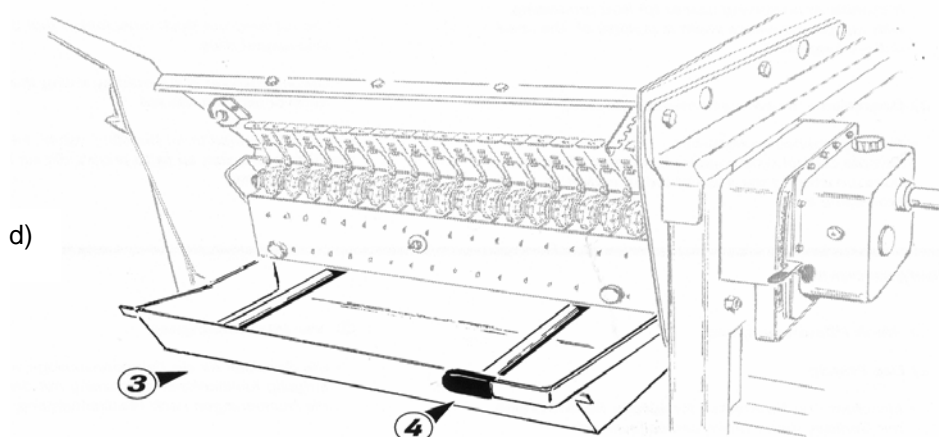
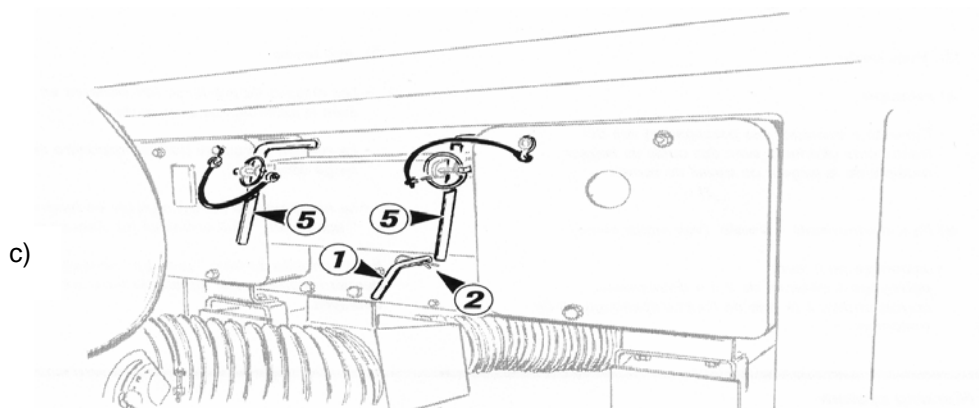

The hopper must be emptied after work, to avoid rodent damage.

c) Half-seed drill disengagement

- Only the right side is declutchable.
- Remove the clip. Pull lever (1) and put clip (2) back in place.
- After completing your $\frac{1}{2}$ pass, do not forget to re-engage the lever. Make sure both shafts are rotating again.

d) Emptying the hopper

- The hopper is emptied into tray (3)
 - Position the tray under distribution and lower lever (4) all the way downwards.
 - To stop seed flow while the hopper is not empty, slightly raise the lever without seeking to put it in the top position.
- For faster emptying, levers (5) can be used.
 - Set the seed drill to transport position
 - Place a container under the distribution hoses.
 - Pull levers (5)
 - Take care to lock those levers with the pins after use.

G : Electronic Tramlines



See page 41 to set tramline rhythm on the Moore Headland Control

The electronic tramliner disengages 2 or 4 seed flow outlets to form tramlines to facilitate further crop treatments

The table below shows typical tramline rhythms for different widths of tramline bouts

Drill (meters)	Width of Sprayer	Half drill shut off for tram lining	Target Bout	No. of bouts to start tramline
	12	No	3	2
	16	Yes	4	2
4	20	No	5	3
	24	Yes	6	3
	28	No	7	4
	32	Yes	8	4
	36	No	9	5
	12	Yes	2	1
6	18	No	3	2
	24	Yes	4	2
	36	Yes	6	3

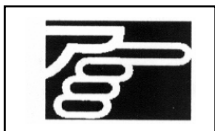

When using half width shut off begin on the left of the field. Don't forget to re – engage the half width shut off before the second drilling bout

Settings

H : Tramline Track Width

Tramline Track Width

The tramline track width is not set in the factory. This will have to be changed to correspond with your own sprayer.

Please make the following measurements

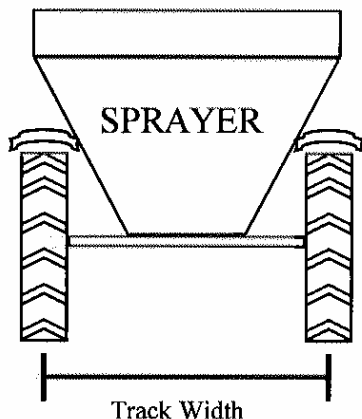

The above measurement can then be used to determine the coulters on each side of the drill that will allow a tramline track width approximately equal to your sprayer track.

Take one half of the sprayer track width, and use this measurement from the centre of the drill to determine the coulters that will be used to tramline on. Repeat this procedure on the other side of the drill.

The selected coulters must then be attached to the tramline pipes on either side of the drill.

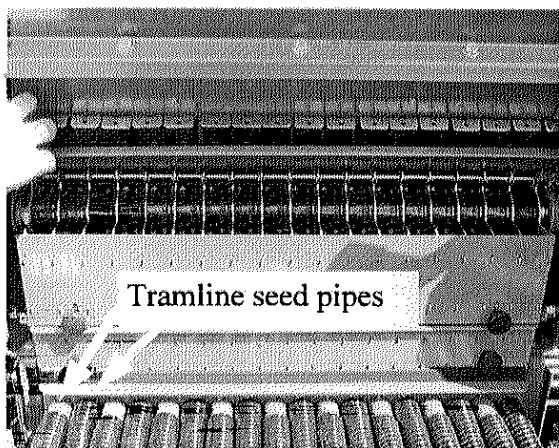

Please ensure that if the seed pipes are changed onto different coulters that they have sufficient length for working position as well as transport position.

Please note: All seed boxes are set up for double row tramlining.

This can be changed to single row if required by closing the appropriate shutters. (W400)

Consult the Manufacturer for further information on changing a W600.

A : Wear Check

e)

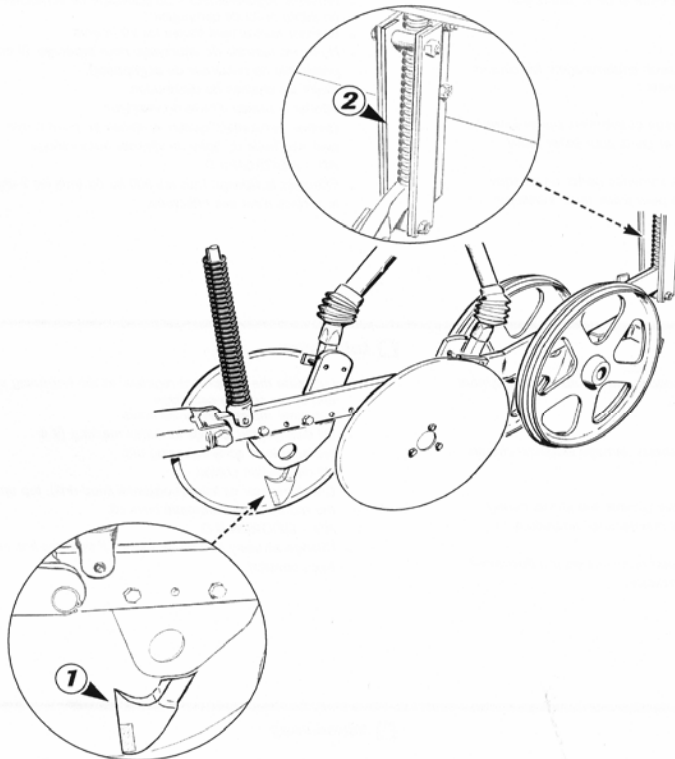

These checks should be regularly repeated, especially when the seed drill has been used on hard or stony soil.

e) Checks

Wear check

- of coulters (1)

Coulters are the essential furrowing part and must retain aggressive shape. Coulters can be rebuilt with suitable welding rods before wear becomes too pronounced.

- of seed drill arm rear guides (2)

NEVER LUBRICATE.

- turn or replace the plates as soon as their thickness is significantly reduced.

Tightening check

- After 10 hours of operation:

Check the tightening of the furrowing system screws: disc securing screws and check tapered roller bearings.

If those roller bearing have play, they should be tightened:

- Remove the dust cover
- Tighten the nut until the disc rotates forcibly
- Release the nut by ¼ turn
- After 20 hours of operation : Check the tightening of the main nuts.

Periodically check wheel rim tightening and tyre pressure:

- Tyres – 500/50-17 (W400): 2 bar
- 500/55-20 (W600): 2 bar

B : Seed Distribution

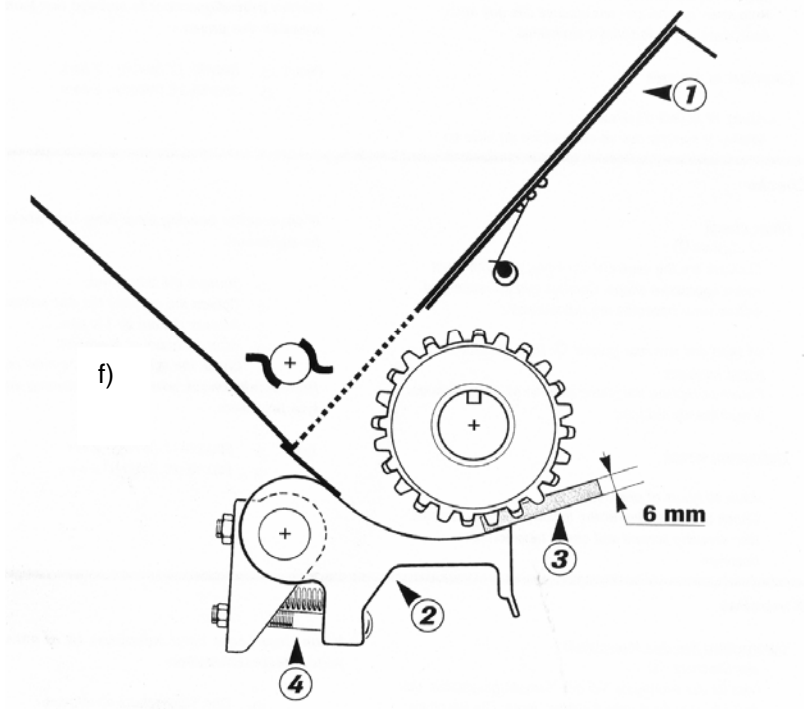

f) Metering devices

- Never leave seed for any length of time in the hopper
- Open shutters (1) and flaps (2) during the storage period
- Never lubricate or grease metering devices and seed pips
- Checks – Incorrect setting of flaps (2) may induce oversowing in the course of work.
 - It is recommended to check and adjust if necessary after each sowing period-
 - Set the flap lever to index 1
 - Begin with visually assessing the distance between the flap and the peg wheel
 - If necessary, insert a 6mm spacer (3) between the flap and large space peg wheel.
 - Adjust the distance with screw (4).

C : Greasing and Lubrication

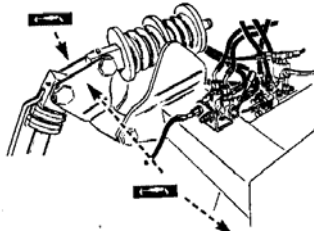
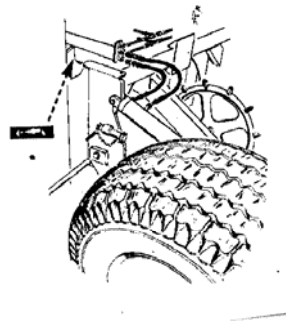
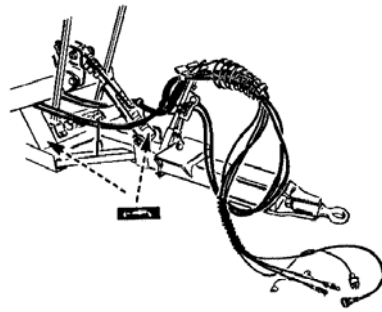
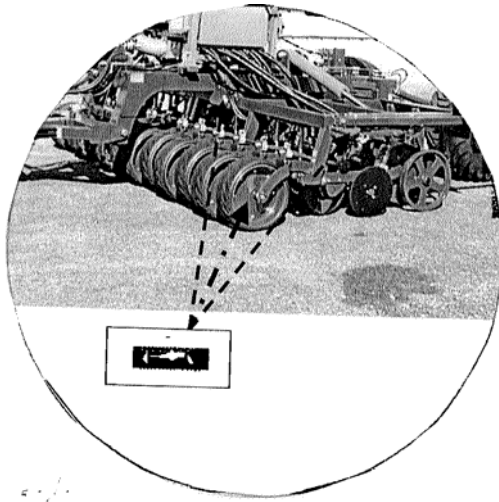

- Lubricate the sowing equipment regularly at the beginning and end of the sowing campaign
- Grease the front Otico press wheels every 120 hours
- Lubricate markers every 20 hours
- Oil tramline springs with spray releasing oil
- Oil distribution chains
- Check variator oil level [horizontal seed drill], top up the red dot with ATF – DEXTRON II D
- Change oil every 500 ha or 2 years if the area has not been covered.

Practical Recommendations

A : Multiplier

g)

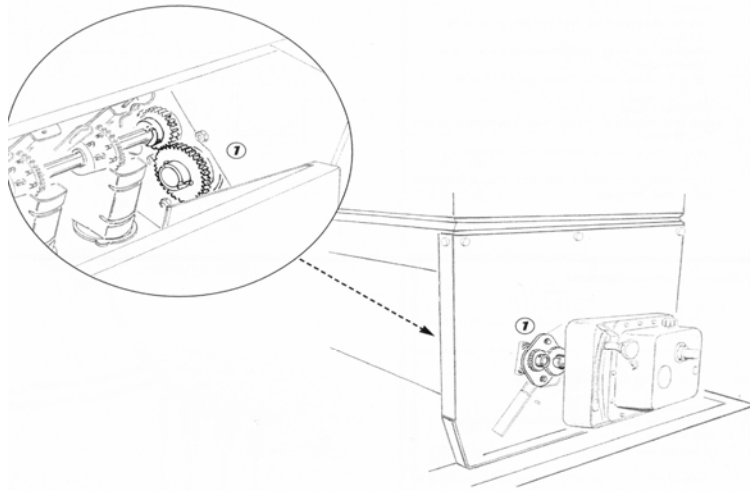

h)

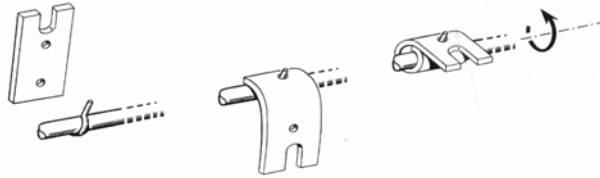

Follow the mounting instructions

g) Variator rate multiplier

- Multiplier (1) is to be used for high-speed operation (≥ 12 km/h) with high seed rate.

Fitting

- Remove the variator (3 screws accessible through the hopper)
- Remove the couplings
- Fit the multiplier from the outside
- Check alignment and tighten the multiplier and variator securing screws.

Operation

- In relation to baseline settings, the flow rate is doubled.
- Follow the column [B] in flow rate tables.

h) Flexible agitator

- Use the flexible agitator with very poorly flowing seed, eg, Rye grass

Fitting

- Hold the rubber flap and roll it around the agitator finger according to the diagram
- Beware of the rotating direction

Practical Recommendations

C : Pre – Emergence Marking

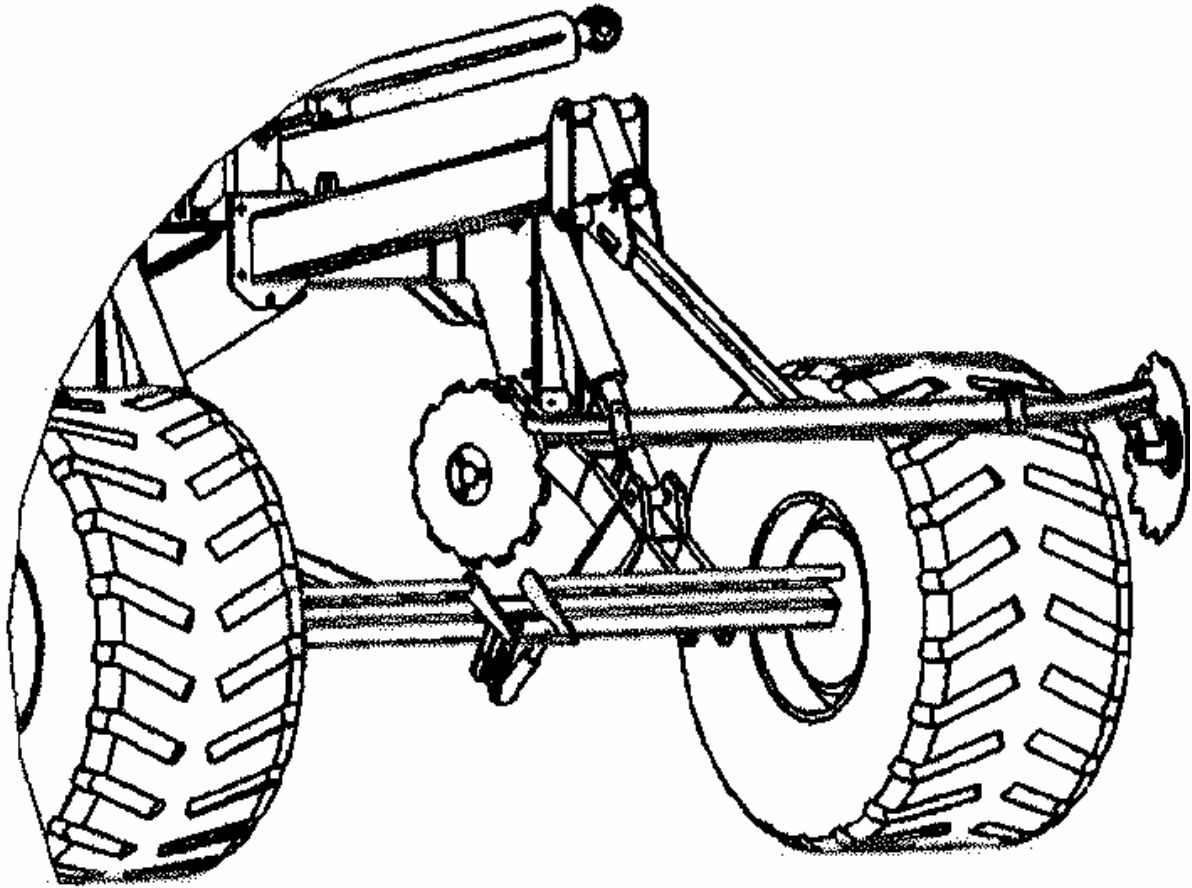

- Pre – Emergence discs operate simultaneously with post – emergence marking out. (Tramlines)
- The marking out track must match that of the disengaged rows
- Ground marking is adjusted by letting the discs “catch” more or less soil.

It is recommended to let the disc “catch in the edge of the first seeded row, so as to project soil

Practical Recommendations



HOW TO PREVENT COMPACTION

- 1. Generalise the use of low-pressure tyres on field equipment to restrict surface compaction.**
Fitting wide tyres or twin wheels is not enough; pressure has to be adapted.
The target is 0.6 bar, in agreement with the tyre manufacturer. When in tow, UNIDRILL does not load the rear wheels of the tractor and weights are not needed in the front!
- 2. Reducing axle load to reduce deep compaction.**
The target load is 6 tonnes per axle; leave all heavier loads on the track. Light tractors are preferable; UNIDRILL is perfect for moderate power, hence lighter tractors.
- 3. Working on dried-out soil.**
Be patient and wait for the right moment to intervene. According to researchers, the soils resists better to compaction as soon as its surface changes colour. After 4-5 years of conservation tillage, the soil drains water faster and becomes more bearing, which reduces waiting.
- 4. Bring calcium and magnesium supplements to compensate medium acidification.**
Aim to maintain pH between 6.5 and 7 to ensure good stability of the clay-humic complex.
- 5. Enrich the soil with organic matter to protect it from compaction and improve resistance.**
Return straw and harvest residues, bring manure, grow forage, avoid plowing...



HOW TO BURY STRAW

- 1. Select the right variety.**
Depending on variety the amount of straw produced varies, as does its resistance to impact. A disease-resistant variety that does not necessarily need end-cycle fungus protection will also be more vulnerable to decomposition agents.
- 2. Fit and adjust the combine.**
Faster rolling and beating breaks down straw more. Well dried, straw is more brittle: harvest those plots first. Fit the harvester with a small straw distributor. Shred the straw in 5-6 mm bits (sharpen the shredder blades, tension the belts...) and distribute it evenly.
- 3. Shred straw and thatch behind the harvester.**
In particular, when catch-crop is short, cutting high and straw poorly distributed, when planning to use a toothed tool...
- 4. Thoroughly mix the straw in the soil and press.**
Do not exceed 5-6cm in depth to facilitate decomposition and not to dilute residues. Pressing with a heavy roll promotes soil/straw contact and decomposition agent action.



HOW TO FEND OFF SLUGS

Practical Recommendations

1. **Plough up stubble early to restrict slug feeding sources.**
2. **Work surface soil rather finely and press to upset and make slugs uncomfortable.**
3. **Keep soil clean by mechanical and chemical destruction and sow early.**
4. **Detect the presence of slugs upon the first rainfall and set traps.**
5. **Sow a little deeper and under fast-emergence conditions.**
6. **Properly close up the sowing furrow, possibly roll. In a risk situation, treat with an appropriate agent.**
7. **Carefully monitor growth after sowing, especially under humid conditions.**



HOW TO FIGHT WEED

1. **Setup conservation tillage only in clean plots**

In particular, perennial weeds should be controlled during the preceding crop.

2. **Plan fighting weed within the cropping cycle.**

Alternate cereals with dicotyledon plants (peas, rape, beet...) as well as winter and spring crops. Take advantage of dicotyledon crops to take effective action against graminaceous weed, and of cereal crops to destroy dicotyledons.

3. **Perform blank sowing between crops to get rid of annual weeds and regrowth.**

Upon combine passage, prepare a bed of homogenous seed with fine, superficial and pressed dirt to obtain an even and as comprehensive emergence of weed seeds as possible. A week before sowing, destroy the emerged plants mechanically or with a total non-remanent weed killer

4. **Do not sow too early to optimize blank seed effectiveness.**

The longer the catch-crop, the more effective the weed killing. Sow the foulest plots last. Trust the swiftness of UNIDRILL action and the quality of its emergences and sow on schedule without any risks.

5. **Setup a clean and strong crop upon sowing**

Use clean, weed-free seed with high germination potential. Lay the seed to obtain fast and grouped emergence, competing with weed.

6. **Use a seed drill that moves little soil, like UNIDRILL**

UNIDRILL only works the seed row, thus reducing the risk of blank-seed-escaped seed emerging. Wide intervals between rows are preferable, like those of the UNIDRILL (16.6cm). Only use the seed drill near harrow when necessary.

7. **Closely monitor flora evolution during growth**

With conservation tillage, usual weeds no longer occur in the same amounts and on the same dates; furthermore, other species may occur. Be prepared for that evolution by updating your botanical knowledge. Do a weekly tour of growing crops, progress through plots along large W-shaped patterns, identify plants and their growing stage, take notes and keep a record for each plot.

8. **Vary the weed-killer chemical family from one year to another.**

9. **Trim borders, fallows and crops before seeding.**

Mow, shred embankments, borders, ditches, fallows rather than applying total weed-killers; this could lead to perennial weed selection and make them hard to eliminate. Some prefer growing Ray-grass on borders; it smothers weeds and is easily controlled with a mower. In crops, destroy residual weed patches by tropical treatment with a regular spraying equipment or manual atomizer.

10. **Avoid disseminating weed seed at harvest.**

Start with cropping the cleanest plots. In weed-infested plots, crop the cleanest parts first. Clean the combine after each passage in a fouled plot.

Flow Rate Tables & Calibration Procedure

A : Reminder of Pre Settings

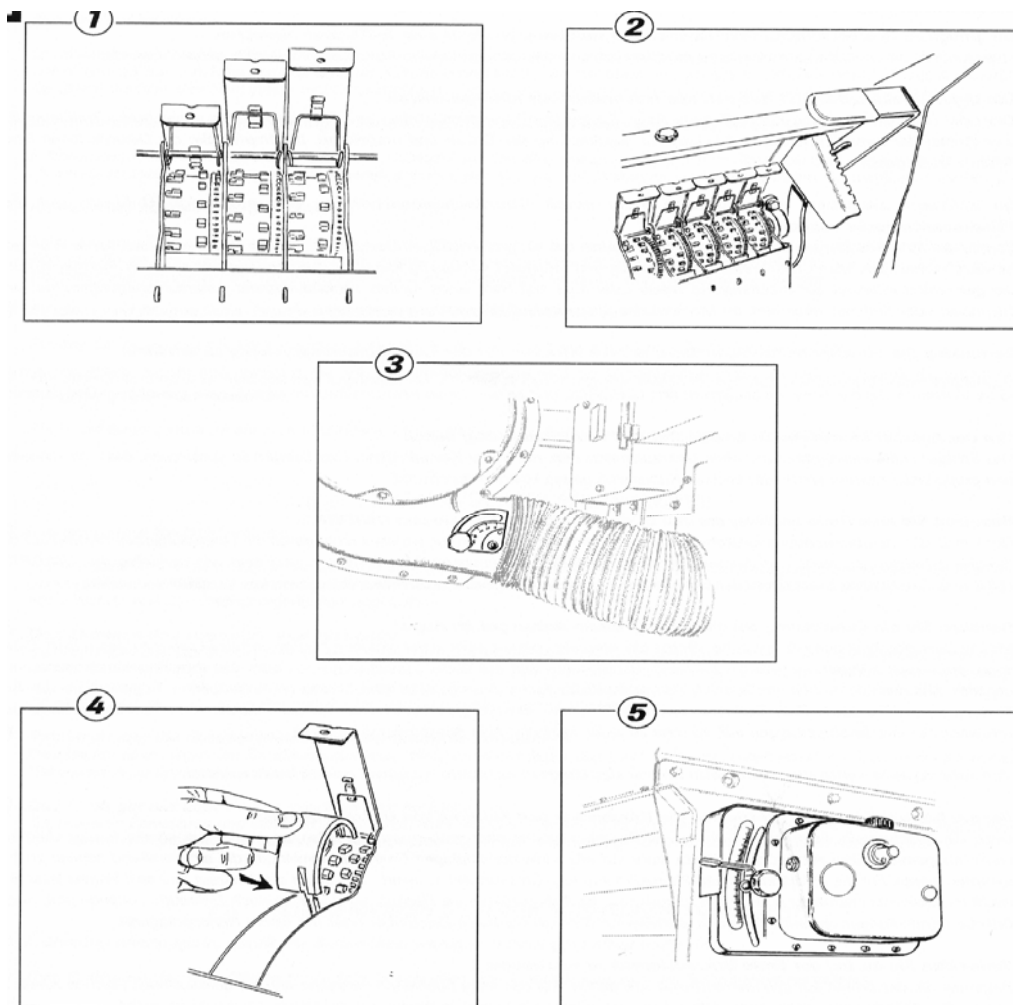

Table settings are merely indicative. Check you flow rate/ha.

REMINDER OF PRE-SETTINGS

- [1] Shutters (3 positions)
- [2] Flap (6 positions)
- [3] Turbine (5 positions)
- [4] Pegs (2 positions)
- [5] Variator (Indices 0 - 90)

FLOW RATE TABLES

- Wheat
- Rapeseed – Barely – Peas – Field peas
- Oats – Mustard – Phacelia – Radish
- Alfalfa – Linseed – Ray-grass – Clover

Flow Rate Tables & Calibration Procedure

				
Colza Rape Raps	1	1	2	3
Luzerne Lucern Luzerne	1	1	1	3
Ray grass Rye grass Ray gras	1	1	1	3
Blé Wheat Weizen	2	1	1	4
Orge Barley Gerste	2	1	1	4
Pois Peas Erbsen	2	5	1	5
Phacélie Phacelia Phazelia	1	1	1	3
Avoine Oat Hafer	2	1	1	4
Lin Linseed Leinsaat	1	1	1	3
Radis Radish Radieschen	1	1	1	3
Moutarde Mustard Senfsamen	1	1	2	3
Féverole Field beans Ackerbohnen	2	6	1	5
Trèfle Clover Klee	1	1	1	3

Flow Rate Tables & Calibration Procedure

An example detailing how to use the calibration chart.

Setting Chart for Wheat.

Note: Row spacing is 16 for both 3/4 metre Unidrill

Working width. No of rows. Row spacing

Working width	No of rows	Row spacing
2,50	17	16
	21	12
3	18	17
	19	16
	21	14
	25	12
3,50	23	15
	29	12
4	24	17
	27	15
	29	14
	33	12
4,5	29	15,5
	33	14
4,8	33	14,5
5	33	15
6	40	
	44	
	48	
6,66	44	
	48	

Blé / Wheat / Weizen							
Seed Rate Kg/ha	12	13	14	15	16	17	
71		20	22	24	26	28	30
80	160	23	25	28	30	32	34
90	180	27	29	32	34	36	39
100	200	30	33	35	38	40	43
110	220	33	36	39	42	44	47
120	240	36	39	42	45	48	51
130	260	39	43	46	49	52	54
140	280	42	46	49	52	55	58
150	300	45	49	52	55	58	61
160	320	48	52	55	58	62	64
170	340	51	54	58	61	64	67
180	360	53	57	61	64	67	70
190	380	56	60	63	67	70	73
200	400	58	62	66	69	72	75
210	420	61	65	68	72	75	78
220		63	67	71	74	77	80
230		67	71	75	78	81	83
240		69	73	77	80	83	85
250		71	75	79	82	84	86

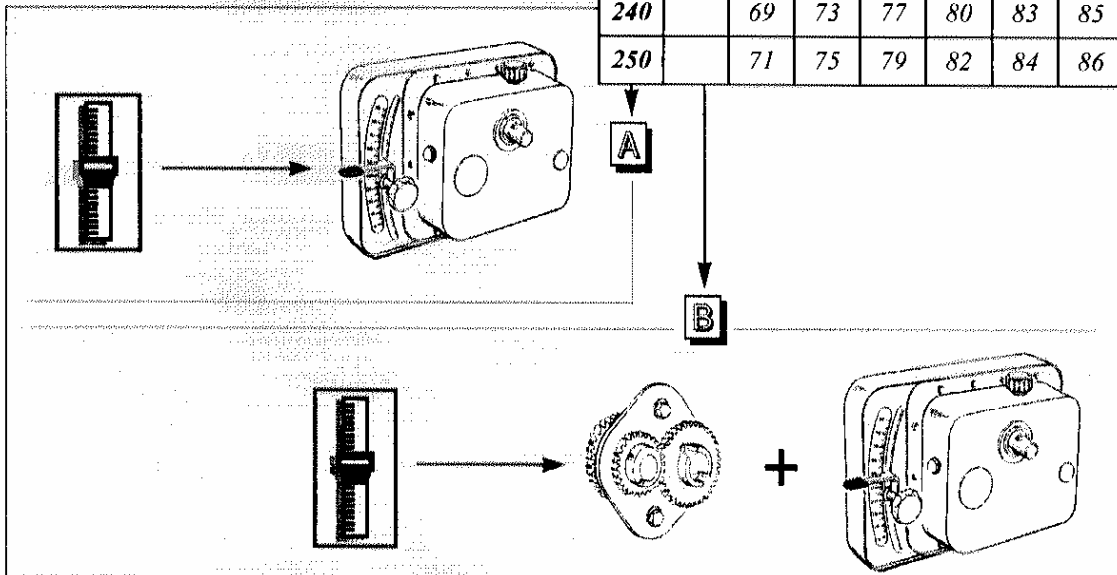

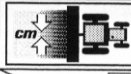
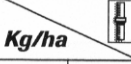

Flow Rate Tables & Calibration Procedure

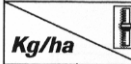
Colza / Rape / Raps							
		12	13	14	15	16	17
							
1	2	4	4	5	5	5	5
1,5	3	6	6	7	7	7	8
2	4	7	8	9	9	10	11
2,5	5	9	10	11	12	12	13
3	6	11	12	13	14	15	16
3,5	7	13	14	15	16	18	19
4	8	15	16	18	19	20	22
4,5	9	17	18	20	22	23	25
5	10	19	21	22	24	26	27
5,5	11	21	23	25	27	29	30
6	12	23	25	27	29	31	33
7	14	27	30	32	34	37	39
8	16	31	34	37	39	42	44
9	18	35	38	41	44	47	50
10	20	39	43	46	49	52	54
11		43	47	50	53	56	58
12		47	50	54	57	59	62
13		50	54	57	60	62	64
14		54	57	60	63	65	66
15		57	60	63	65	66	
A	B						

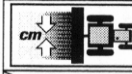
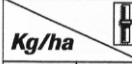
Orge / Barley / Gerste							
		12	13	14	15	16	17
							
90	180	33	36	38	41	44	47
95	190	35	38	41	44	47	49
100	200	36	40	43	46	49	52
105	210	38	42	45	48	51	54
110	220	40	44	47	50	54	57
120	240	44	48	51	55	58	61
130	260	48	52	55	59	62	65
140	280	51	55	59	63	66	69
150	300	55	59	63	66	70	73
160	320	58	62	66	70	73	76
170	340	61	65	69	73	76	80
180	360	64	68	72	76	79	83
190	380	67	71	75	79	82	86
200		70	74	78	82	85	89
210		72	77	81	85	88	
220		75	79	83	87		
240		79	84	88			
250		82	86				
160		84	89				
280		88					
A	B						

Pois / Peas / Erbsen							
		12	13	14	15	16	17
							
120	240		11	13	16	18	20
130	260	11	13	16	18	21	23
140	280	13	15	19	21	24	26
150	300	16	18	21	24	26	29
160	320	18	21	24	26	29	32
170	340	20	23	26	29	32	35
180	360	22	25	28	32	34	37
190	380	24	28	31	34	37	40
200	400	26	30	33	36	39	42
210	420	28	32	35	39	42	45
220	440	31	34	38	41	44	47
240	480	34	38	42	45	49	52
250		36	40	44	47	51	54
260		38	42	46	49	53	56
280		42	46	50	53	57	60
300		45	49	53	57	60	63
320		49	53	57	60	63	66
340		52	56	60	63	66	69
360		55	59	63	66	69	72
380		57	62	65	69	72	74
A	B						

Féverole / Field beans / Ackerbohnen							
		12	13	14	15	16	17
							
100	200	12	14	15	16	18	19
105	210	13	14	16	17	19	20
110	220	14	15	17	18	20	22
120	240	15	17	19	21	22	24
130	260	17	19	21	23	25	27
140	280	19	21	23	25	27	30
150	300	21	23	25	27	30	32
160	320	22	25	27	30	32	35
170	340	24	27	30	32	35	38
180	360	26	29	32	35	38	41
190	380	28	31	34	37	40	44
200	400	30	33	36	40	43	47
210	420	32	35	39	42	46	49
220	440	34	37	41	45	49	52
240	480	38	42	46	50	54	58
250		40	44	48	52	56	60
260		42	46	51	55	59	63
280		46	51	55	60	64	68
300		50	55	60	64	69	73
320		54	59	64	69	73	77
A	B						

Warranty

In this warranty Moore Uni-Drill is referred to as the Company.

1. Subject to the provisions of this warranty the Company Warrants each new machine sold by it to be sold free from any defect in material or workmanship.
2. If the machine or part there of supplied by the Company is not in accordance with the warranty given in clause 1 the Company will at its option;-
 - (a) Make good the machine at the Company's expense, or
 - (b) make an allowance to the purchaser against the purchase price, or replace the machine as soon as reasonably practicable.
3. This warranty shall not oblige the Company to make any repayment in respect of loss of profit or other consequential loss or contingent liability of the purchaser alleged to arise from any defect in the machine or impose any liability on the company other than that contained in clause 2.
4. Any claim under this warranty must be notified to the company in writing specifying the matters complained of within 12 months from the date of receipt by the purchaser or his/her nominee of the machine.
5. Any claim under this warranty must be made by the original purchaser of the machine and is not assignable to any third party.
6. If the purchaser hires out the machine to any third party the warranty shall apply only to matters notified to the Company within 90 days of the date of delivery and clause 4 shall be read as if the period of 90 days were substituted for the period of 12 months.
7. **The warranty will cease to apply if:-**
 - (a) **any parts not made, supplied or approved in writing by the Company are fitted to the machine, or**
 - (b) **any repair is carried out to the machine other than by or with the express written approval of the Company, or**
 - (c) **any alterations not expressly authorised by the Company in writing are made to the machine, or**
 - (d) **the machine is damaged by accident, or**
 - (e) **the machine is abused or overloaded or used for a purpose or load beyond its design capabilities.**
8. Any dispute as to whether the goods are sold free from any defect in workmanship or materials shall be referred to a single arbitrator to be agreed between the company and the buyer.

Warranty

Important

This instruction manual is based on experience and results obtained during development of the Tandem Uni – drill. Hints and guide lines are to be regarded as general advice, entailing no responsibility whatsoever on the part of Moore Uni drill and / or its representatives. All responsibility for usage, road transport, maintenance and repair of the drill rests with the owner/driver.

Local conditions affecting crop sequence, soil type, climate etc. may require procedures different to those mentioned in this manual.

The owner/driver is solely responsible for using the drill correctly in every respect. Moore Uni – Drills are subject to thorough quality assurance inspection and function testing before delivery. The user/purchaser shall retain sole liability for insuring the equipment is functioning correctly when in use. Moore Uni-Drill Ltd accepts no liability for losses arising from incorrect use of the drill, including its depth control and seed dosage equipment. Follow the instructions carefully for setting the depth control and seed rate dosage.

In accordance with the program of continuous development at Moore Uni-Drill Ltd, alterations in the specification may be made at any time without notice.

Therefore Moore Uni-Drill Ltd will not accept responsibility for any discrepancies which may occur between the specifications contained in this publication.

DP400A and DP600A Parts booklet



2002 seeding line

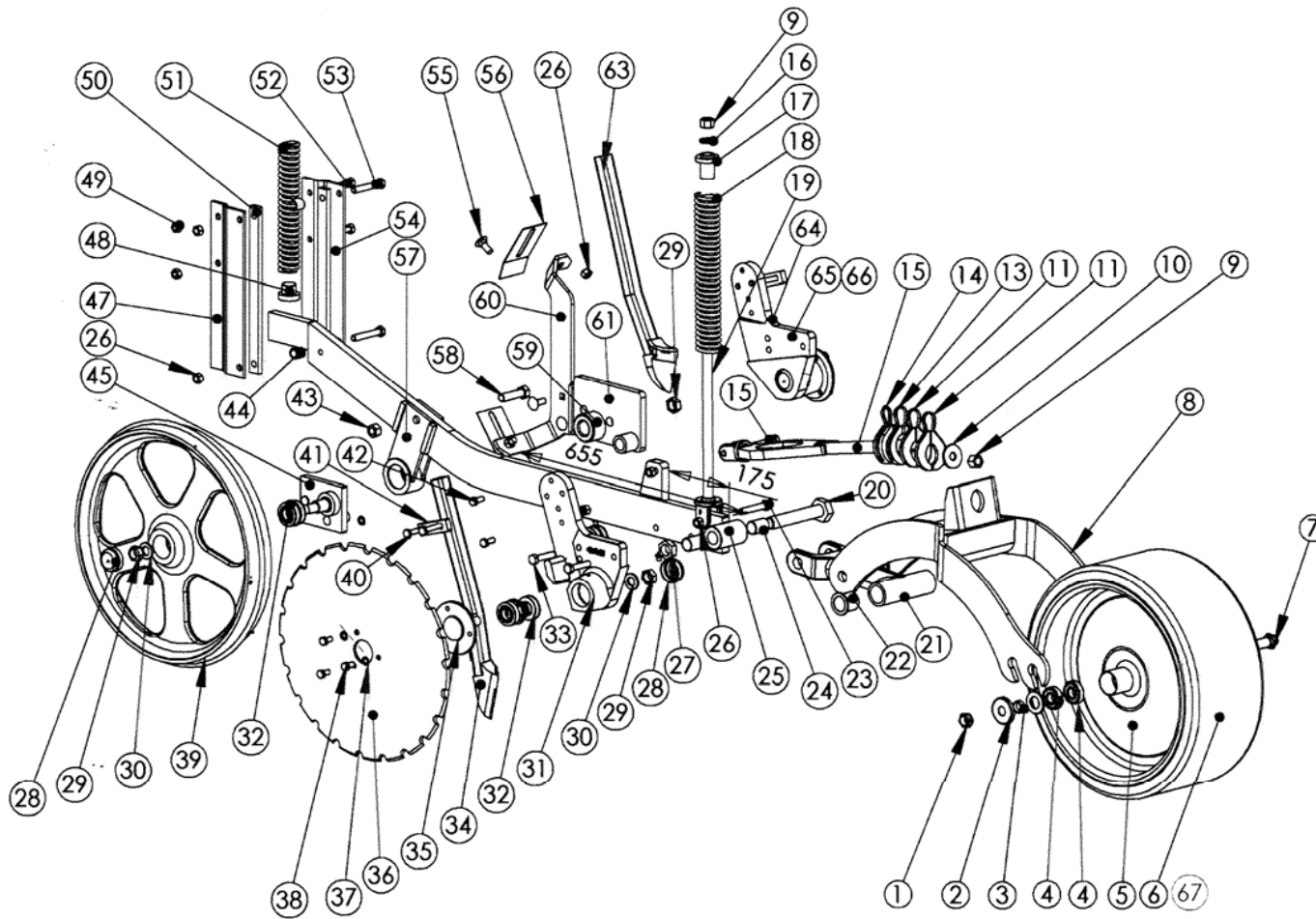

Ref	Part No	Description
1	010015	M20 Recessed Binx Nut
2	210007	Outer Washer
3	210006	Spacer Tube
4	210004	Farm flex Wheel Bearing
5	210002	Farm Flex Rim
6	210003	Farm Flex Tyre
7	010013	Farm Flex Wheel Axle
8	020005	Front Wheel Carrier
9	140017	M16 Nyloc Nut
10	010225	16mm Depth Clip Stopper
11	550003	¼" Depth Clip
12	N/A	N/A
13	550002	½" Depth Clip
14	550001	1" Depth Clip
15	020111	Fab Depth Control Lever
16	140016	M16 Nyloc Washer
17	720001	Tandem Front Spring Locator
18	690003	Tandem Front Spring
19	570005	Front Spring Rod
20	020015	Pivot Arm Bolt
21	020015	Tandem Pivot Arm Bolt
22	720002	Pivot Arm Bushes
23	140025	M12 x 70 Bolt
24	720004	Drag Arm Boss Bush
25	020107	Tandem MK1 Drag Arm
26	140030	M12 Nyloc Nut
27	010023	1" unF Slim Binx Nut
28	560004	Small Dust Cap
29	140057	¾" unF Nyloc Nut
30	140006	M20x35x5mm hd washer
31	570004	Disc Mounting Bracket Right Hand
32	180001	1" Timken Taper Roller Bearing
33	140029	M12 x 55 Bolt
34	020011	Right Hand Tungsten Coulter
35	010016	Disc Hub
36	600001	450mm Notched Disc
37	140039	3/8" Spring Washer
38	140055	3/8"x3/4" unF Set Screw
39	010222	Cambridge Press Wheel
40	140033	M10 x 70 Bolt
41	010017	Seed Tube Retainer
42	140040	M10 x 20 Set Screw
43	140018	M16 Binx Nut
44	010027	Distance Piece
45	020106	Uni drill Bogie Short Arm
46	N/A	N/A
47	010165	Drag arm Guide Plate r/h
48	720003	Rear Spring Locator
49	140041	M10 Nyloc Nut
50	010026	Steel Wear Bar
51	690002	Tandem Rear Spring
52	140033	M10 x 55 Bolt
53		
54	010024	Drag Arm Guide Plate l/h
55	140026	M12 x 30 Cup Square
56	010244	Super Scrapper Blade
57	020104	Uni Drill Bogie Mount
58	140011	M16 x 55 Bolt
59	180002	30mm Uni Pac Bearing
60	010223	Classic Bogie Scraper Mounting
61	020104	Uni Drill Bogie Long Arm
62	N/A	N/A
63	020009	Left Hand Tungsten Coulter
64	570003	Disc Mounting Bracket L/H
65	020048	Classic Left Hand Bracket
66	020085	Classic Right Hand Bracket
67	210001	Complete Farm Flex Wheel

53	140024	M12 x 80 Bolt
54	010024	Drag Arm Guide Plate l/h
55	140026	M12 x 30 Cup Square
56	010244	Super Scrapper Blade
57	020104	Uni Drill Bogie Mount
58	140011	M16 x 55 Bolt
59	180002	30mm Uni Pac Bearing
60	010223	Classic Bogie Scraper Mounting
61	020104	Uni Drill Bogie Long Arm
62	N/A	N/A
63	020009	Left Hand Tungsten Coulter
64	570003	Disc Mounting Bracket L/H
65	020048	Classic Left Hand Bracket
66	020085	Classic Right Hand Bracket
67	210001	Complete Farm Flex Wheel

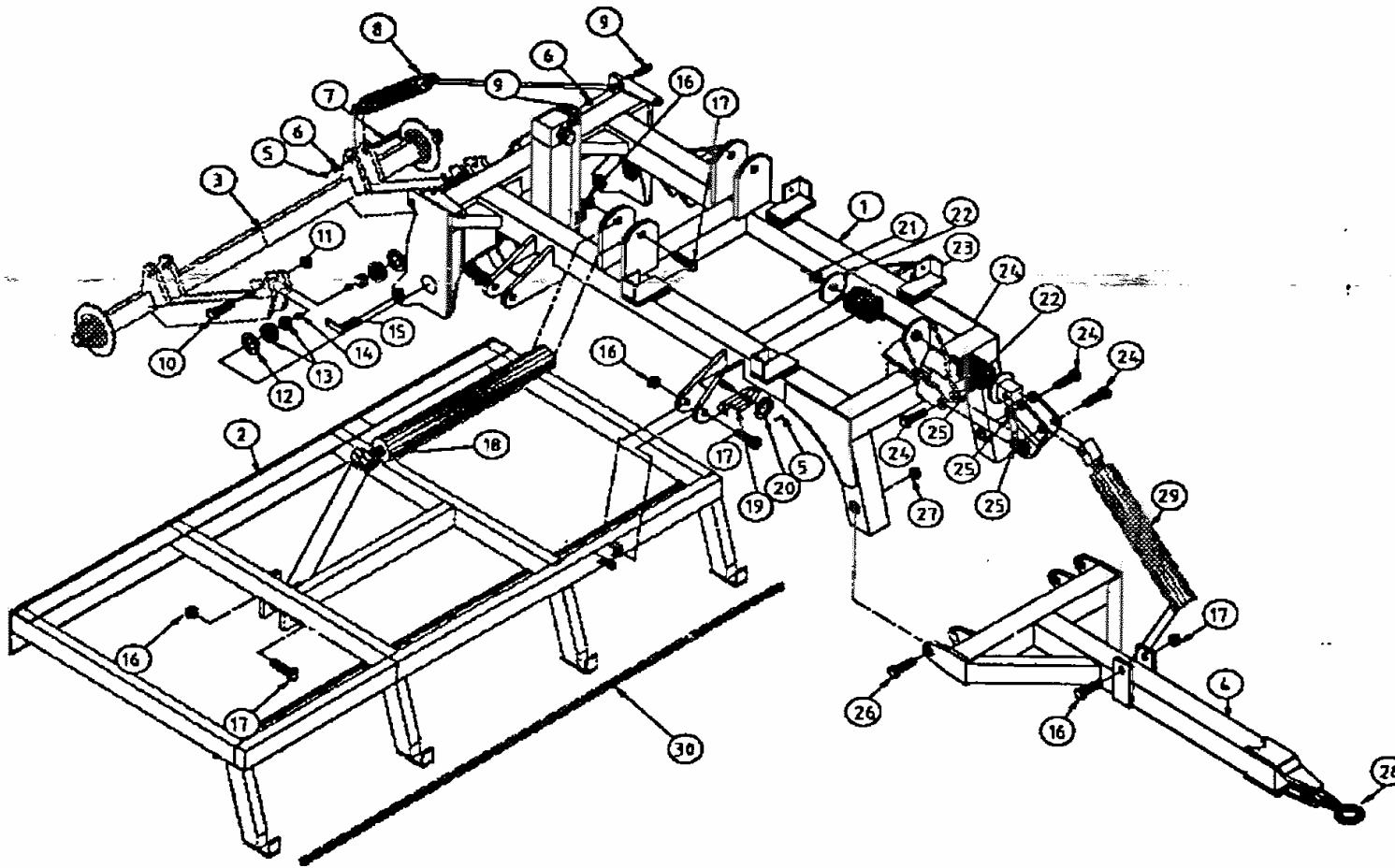

REF	Part No	Description
1	622-0004	6M HP Chassis
2	621-0004	6m HP wing
3	126-04	Axle Unit
4	624-0004	Draw Bar
5	A153	M8 x 40 roll pin
6	A199	1 1/4" x 1" tension bush
7	128-46	Ram to chassis pin
8	BAC358	Rear Axle Ram
9	128-46	Ram to chassis pin
10	A101	1" x 6" UNC bolt
11	A130	1" UNC Lock nut
12	130-1234	Pivot Collar axle unit
13	A156	1 3/8" Taper Bearing
14	131-1234	Pivot Bush axle unit
15	125-1134	Transport Pin
16	A129	1 1/4" UNC nyloc
17	A117	1 1/4" x 7 1/2" UNC Bolt
18	BAC 808	Wing Ram
19	422-11	Wing Lock Profile
20		1 1/4" washer
21		Spring unit collar
23		Spring Pressure adjuster
24		1 1/4" x 5" UNC bolt
25	A129	1 1/4" UNC nut
26		1 1/4" x 8" nut
27	A07-942	Swivel hitch
28	BAC 093	Depth Control Ram
29	161-8	Front Pivot bar

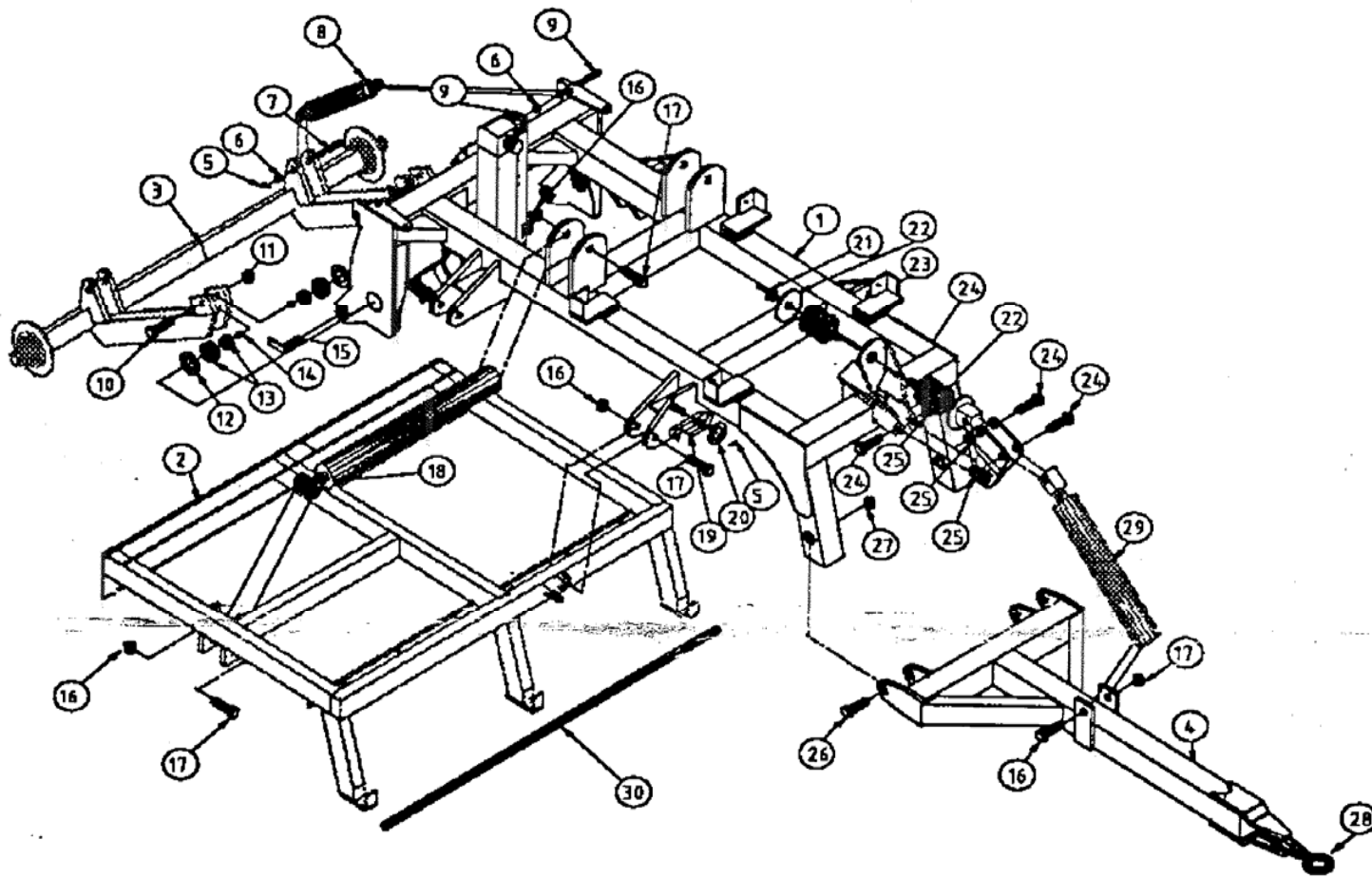

REF	Part No	Description
1	422-0004	6M HP Chassis
2	421-0004	6m HP wing
3	126-04	Axle Unit
4	424-0004	Draw Bar
5	A153	M8 x 40 roll pin
6	A199	1 1/4" x 1" tension bush
7	128-46	Ram to chassis pin
8	BAC358	Rear Axle Ram
9	128-46	Ram to chassis pin
10	A101	1" x 6" UNC bolt
11	A130	1" UNC Lock nut
12	130-1234	Pivot Collar axle unit
13	A156	1 3/8" Taper Bearing
14	131-1234	Pivot Bush axle unit
15	125-1134	Transport Pin
16	A129	1 1/4" UNC nyloc
17	A117	1 1/4" x 71/2" UNC Bolt
18	BAC 808	Wing Ram
19	422-11	Wing Lock Profile
20		1 1/4" washer
21		Spring unit collar
23		Spring Pressure adjuster
24		1 1/4" x 5" UNC bolt
25	A129	1 1/4" UNC nut
26		1 1/4" x 8" nut
27	A07-942	Swivel hitch
28	BAC 093	Depth Control Ram
29	141-8	Front Pivot bar

Moore Solo Marker Complete

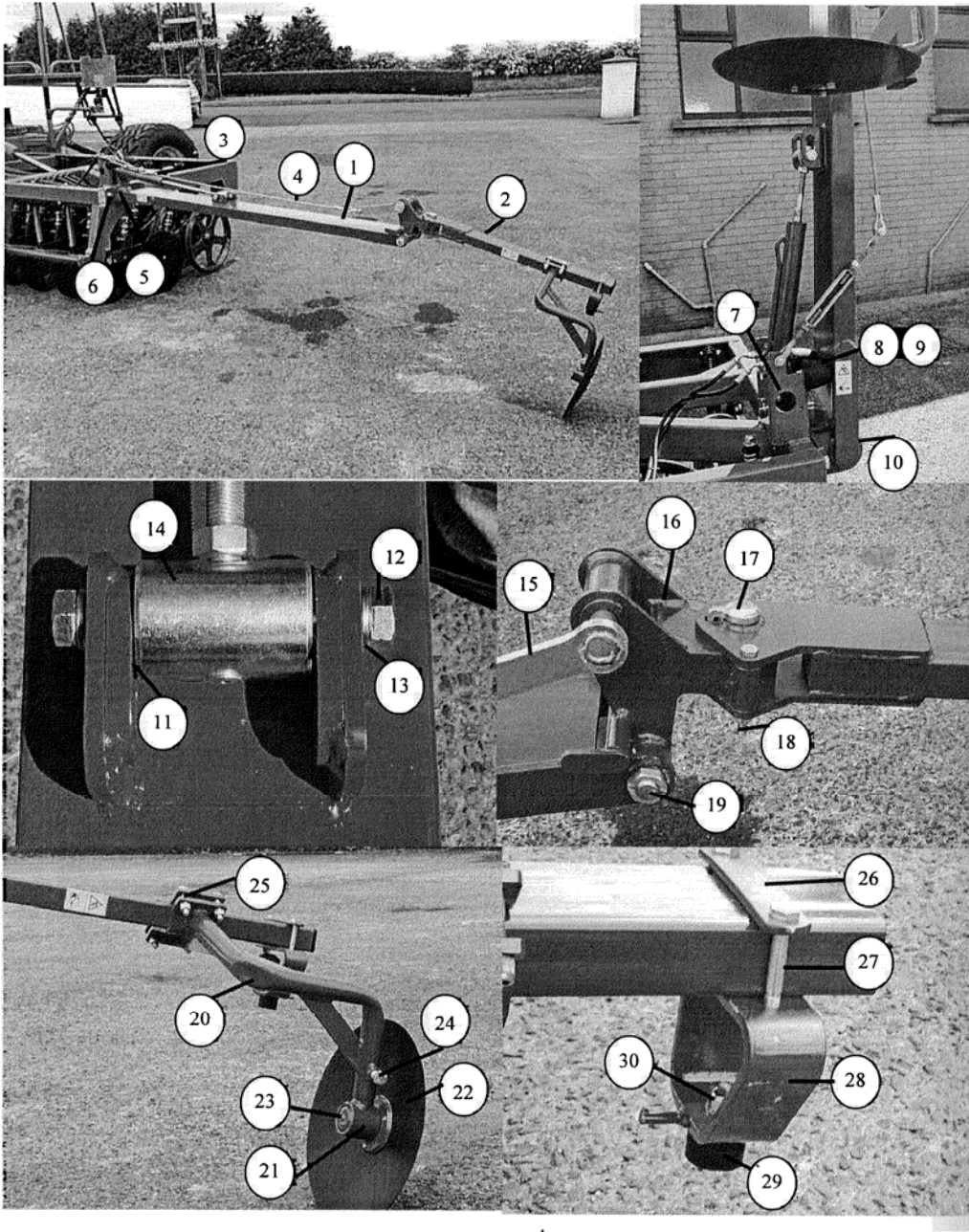

ITEM	PART No	DESCRIPTION	ITEM	PART No	DESCRIPTION
1	SM-03A	Main Marker Arm	17	SM - 12A	Break off pin
2	SM-06A	Outer Marker-Arm	18	A246	Shear Bolt M10 X 100
3	SPI - 01	Moore Solo Marker Ram	19	SM - 07A	Main Marker Pin
4	S720174	Retractor Cable	20	SM - 10A	Disc Mounting Arm
5	SM-02A	Marker Swivel Bracket	21	SM - 08A	Dished Disc hub Assembly
6	A102	Marker Swivel Bracket Bolt 3/4 X 4x1/2 UNC	22	A160D	Dished Disc
7	A107	Marker Ram Pivot Bolt M16 X 50	23	A182	Dust Cap - Small
	A137	M16 Nyloc Nut	24	A254	M16 X 40 Setscrew
8	KP5058-KP	Rubber Buffer 75 X 89	25	A111	M12 X 55 Bolt
9	A138	Nut M12 Nyloc		A138	Nut M12 Nyloc
10	A182	Dust Cap - Small	26	S996321	Buffer Support Bracket
11	SM - 26	Ram - Slot Bush	27	A214	M10 X 80 Bolt
12	A210	Ram Bolt M16 X 45		A139	Nut M10 Nyloc
13	A174	M16 Spring Washer	28	S1 091 542	Bottom Buffer Bracket
14	SM - 31	Ram Mounting Boss	29	S793704	Rubber Buffer
15	SM - 09A	Retractor Assembly	30	A139	Nut M10 Nyloc
16	SM - 05A	Solo Marker Knuckle			

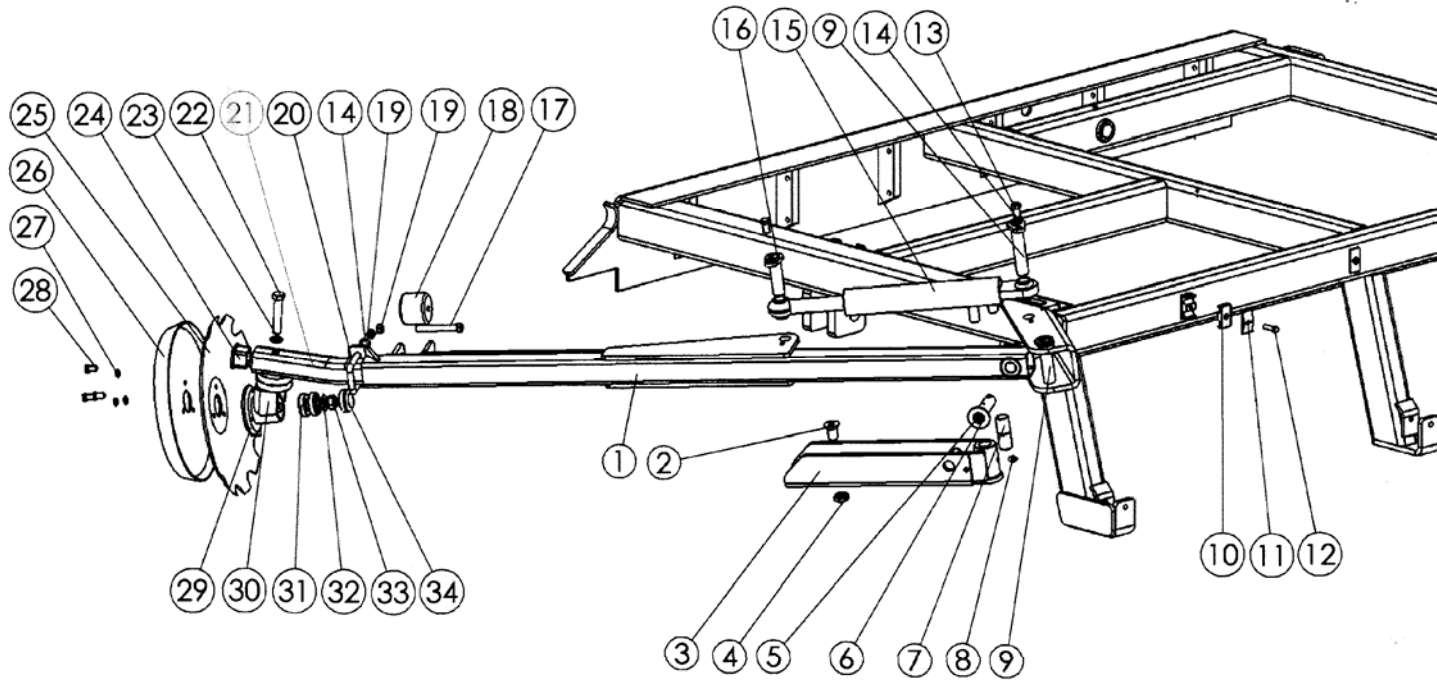

REF	Part No	Description
1	020043	DPA marker Main Arm
2	140142	M20 x 25 set screw
3	020044	DPA Marker hinge
4	140140	M20 half nut
5	140190	M8 Straight grease nipple
6	020133	DPA marker hinge pin assy
7	240003	Devol Drag Arm bush
8	140190	M8 Straight grease nipple
9	020068	DP Marker Swivel Pin Assy
10	400001	3/8 hyd pipe clamp
11	400003	3/8 hyd pipe clamp top clamp
12	140088	M8 x 35 set screw
13	140085	M12 x 25 set screw
14	140084	M12 washer
15	080014	DPA Series marker ram
16	020046	DPA marker arm ram pin
17	140082	M12 x 100 bolt
18	010106	Marker roller
19	140030	M12 nyloc
20	250001	U bolt 50 x 50
21	020134	DPA 400 outer marker arm
22	140086	M16 x 90 bolt
23	140087	M16 lock washer
24	480001	50 x 50 end cap
25	600002	Notched Marker disc
26	020132	Depth Ring
27	140039	3/8" h/d Spring washer
28	140055	3/4 x 3/8 set UNF screws
29	010016	Disc mounting hub
30	020125	Marker hub mounting assy
31	180001	1" Timken bearing pack
32	140006	M20 x 35 x 5 HD washers
33	140057	3/4 UNF cone lock
34	560004	Small dust cap

VUE ECLATEE

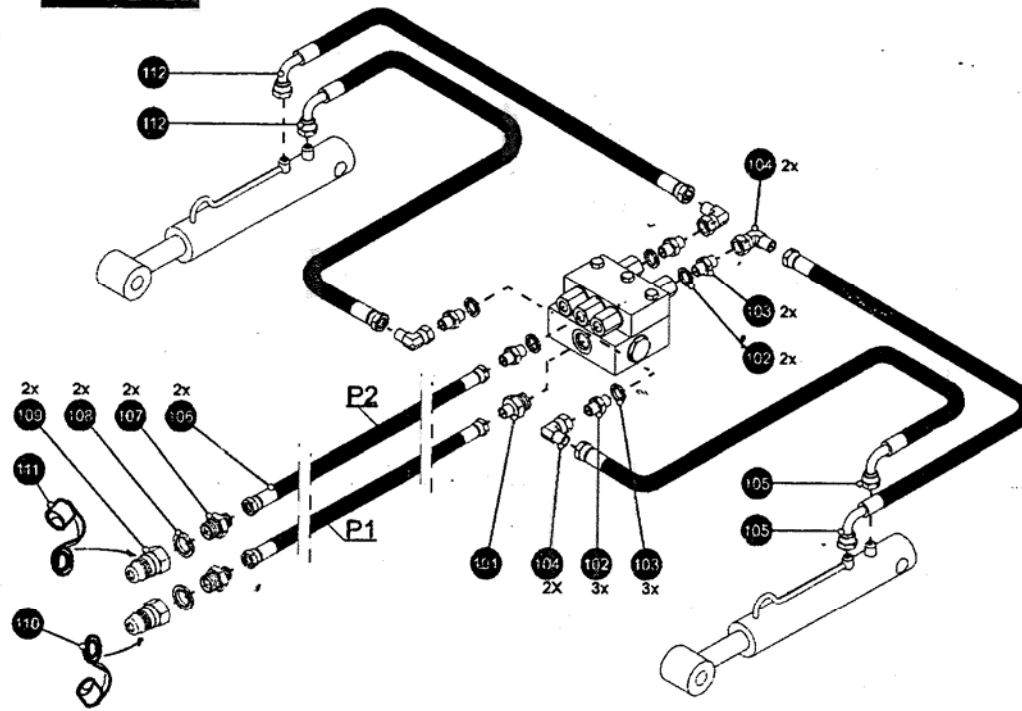

DÉTAIL BLOC 100

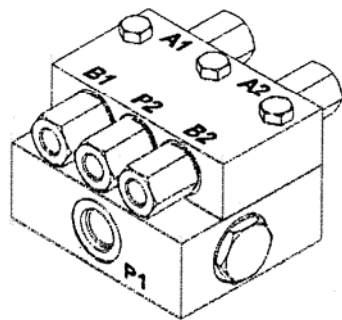

SCHEMA HYDRAULIQUE

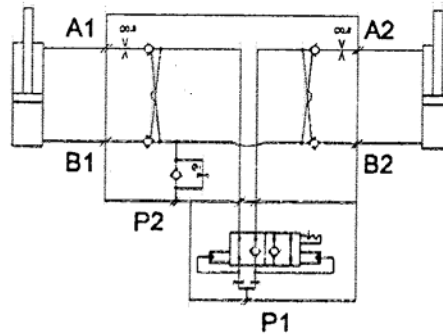

REF. 021020MP

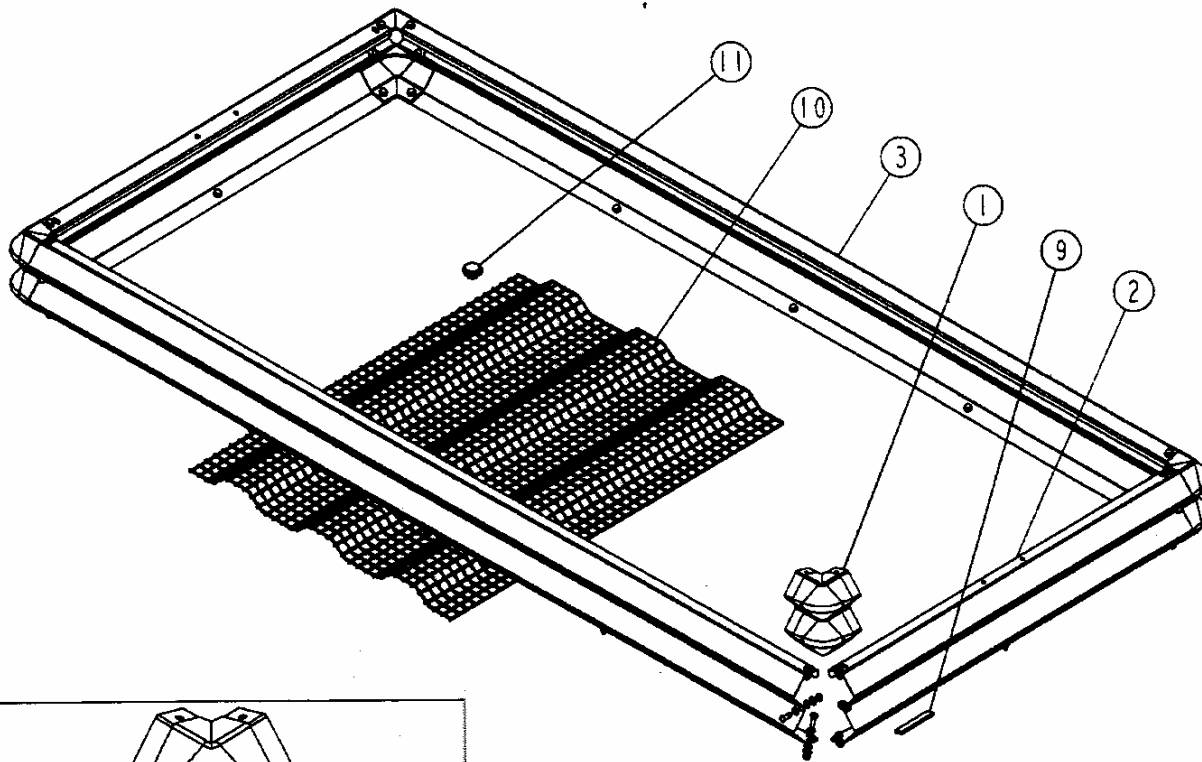

REP	CODE	DÉSIGNATION
1	973045	Coin rehausse double
2	997618	Rehausse2larg uw
3	997617	Rehausse2long uw
4	573008	Rondelle nylon pa66 8
5	573808	Rondelle m8 n inox a2 70
6	555825	Vis bhc 8x25 inox a2 70
7	558825	Vis h 8x25 inox a2 70 fp
8	571408	Ecrou frein nylon h8 inox a2 70
9	794021	Bande adhesif 1 face l 7m50
10	998183	Tamis uw
11	900010	Poignee de cmde h8 inox

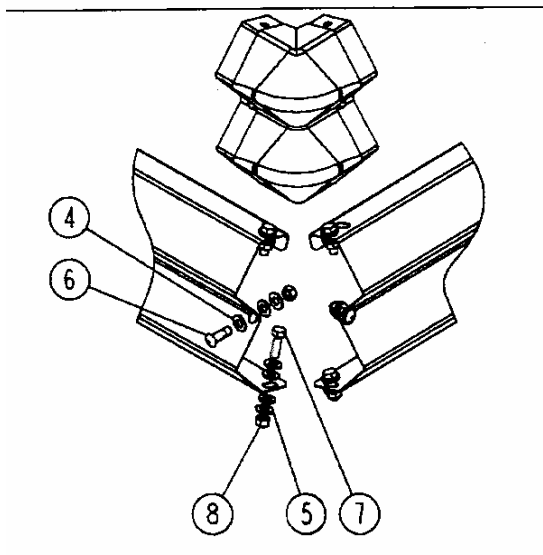

W Seed box hopper extension

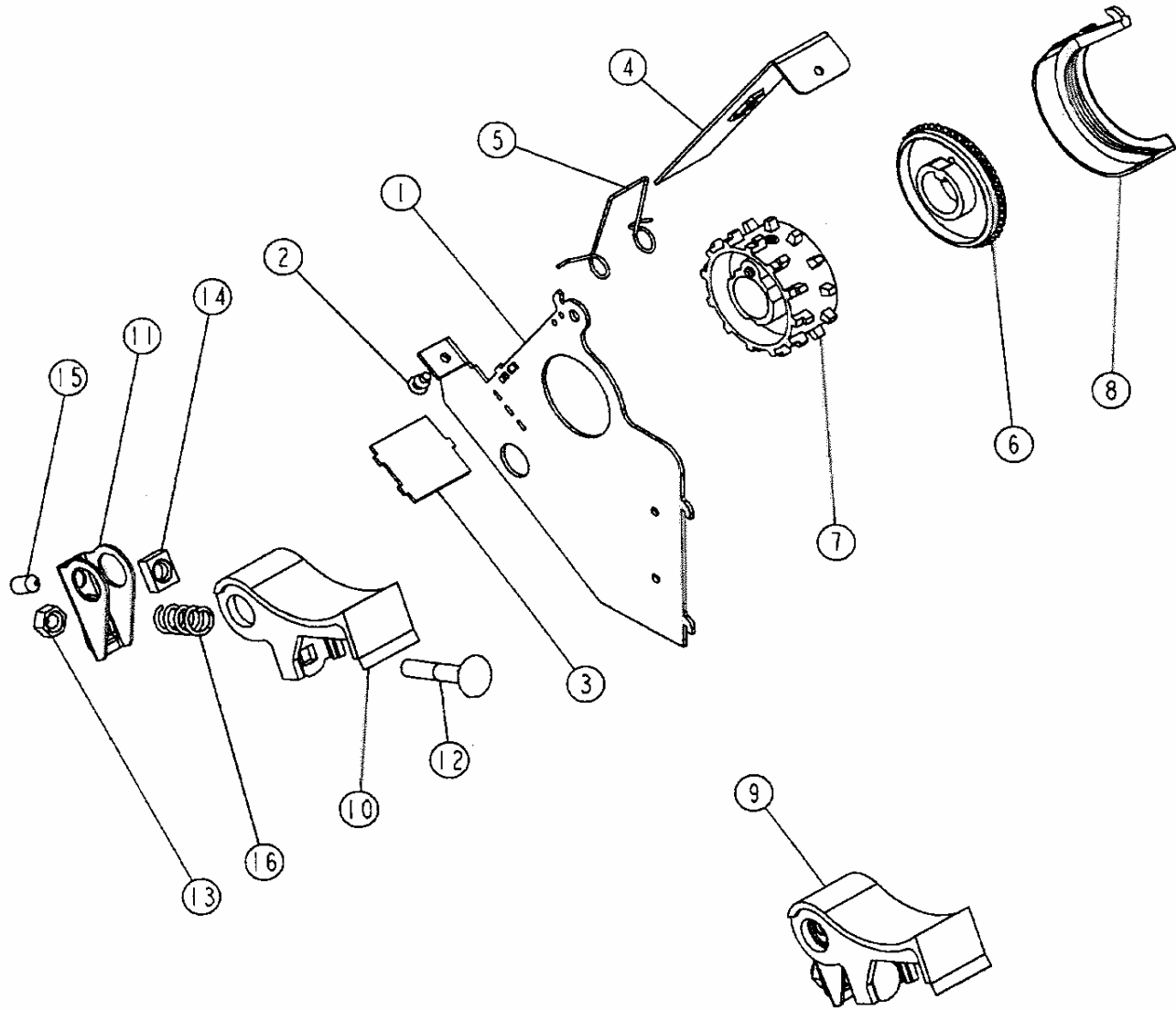

REP	CODE	DÉSIGNATION
1	971026	Boitier de distribution pi
2	598041	Rivet aveugle 4x10 alu
3	965056	Entretoise sp
4	907381	Trappe de trappe
5	981404	Ressort de trappe sp
6	901537	Roue fine
7	900520	Roue a ergot mo
8	985210	Obturateur sp
9	910100	Clapet de fond mo
10	985209	Clapet de fond
11	904599	Support de sabot
12	525895	Vis trcc 8x45 zn 6 c fe
13	571458	Ecrou frein h8 zn 6 c fe
14	571806	Ecrou carre m8 zn 6 c fe 15x6
15	540855	Vis sthc 8x15 zn 6 c fe bp90
16	909081	Ressort de sabot

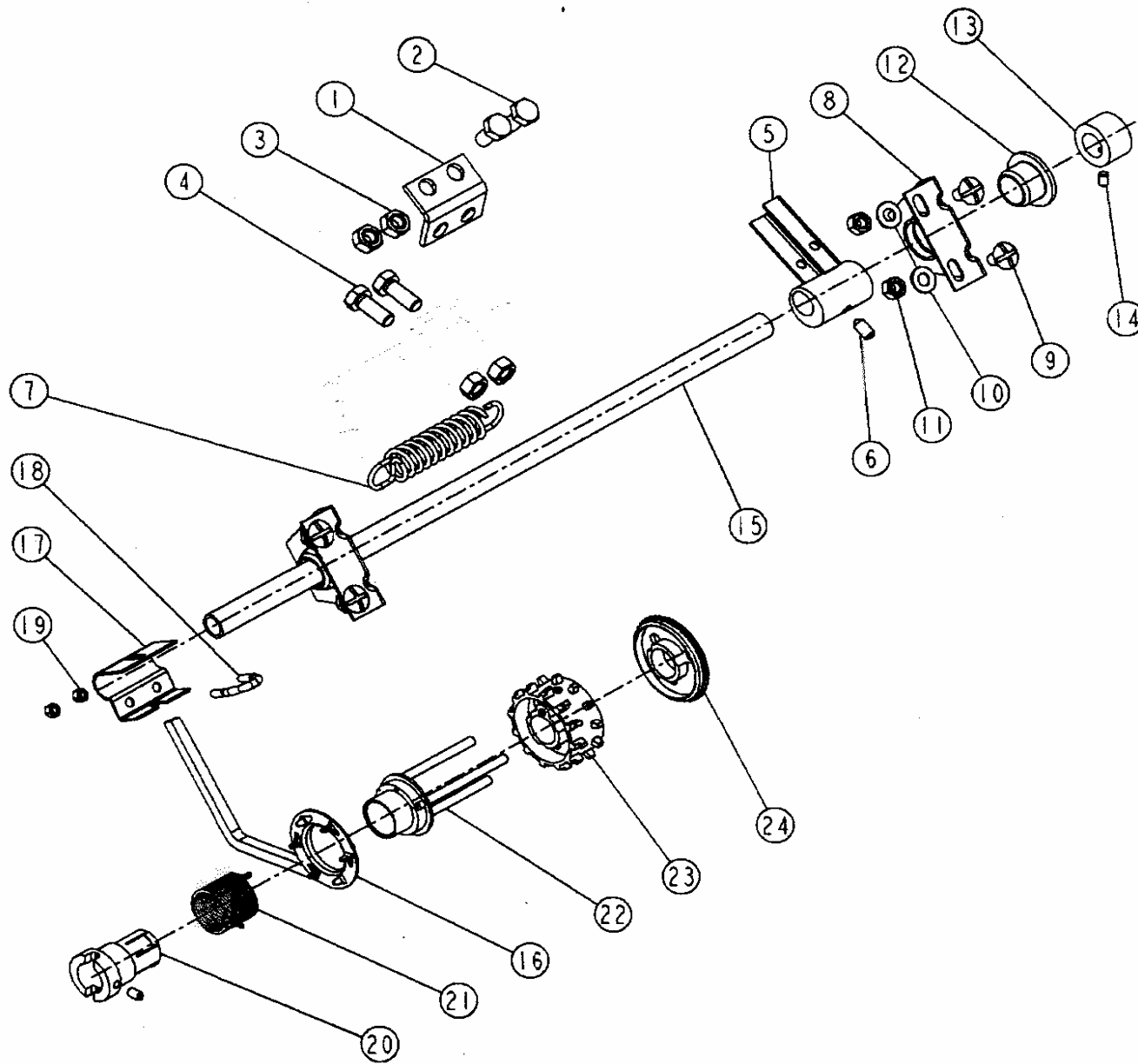

REP	CODE	DÉSIGNATION
1	967054	Platine de verin
2	552070	Vis h 10x20 zn 6 c fe
3	571210	Ecrou h10 zn 6 c fe
4	552076	Vis h 10x25 zn 6 c fe fst
5	909508	Butee réglable so
6	540855	Vis sthc 8x15 zn 6 c fe bp90
7	908010	Ressort d ouverture
8	901473	Pallier d arbre d ergot
9	535853	Vis trl 8x16 zn 6 c fe
10	573158	Rondelle m8n zn 6 c fe
11	571208	Ecrou h8 zn 6 c fe
12	985009	Bague de pallier guidage
13	901571	Butee de réglage tramlines
14	554610	Vis sthc 6x10 bout cuvette
15	992332	Barre de débrayage uw
16	918147	Fiasque débrayage sp so
17	906168	Etrier de repérage
18	901578	Bride d etrier
19	571205	Ecrou h5 zn 6 c fe
20	923067	Recepteur tramlines
21	981405	Ressort d embrayage
22	914101	Plateau sp so
23	910361	Roue a ergot tram sp
24	985022	Roue fine tramlines sp

W Seed box Distributor Assembly

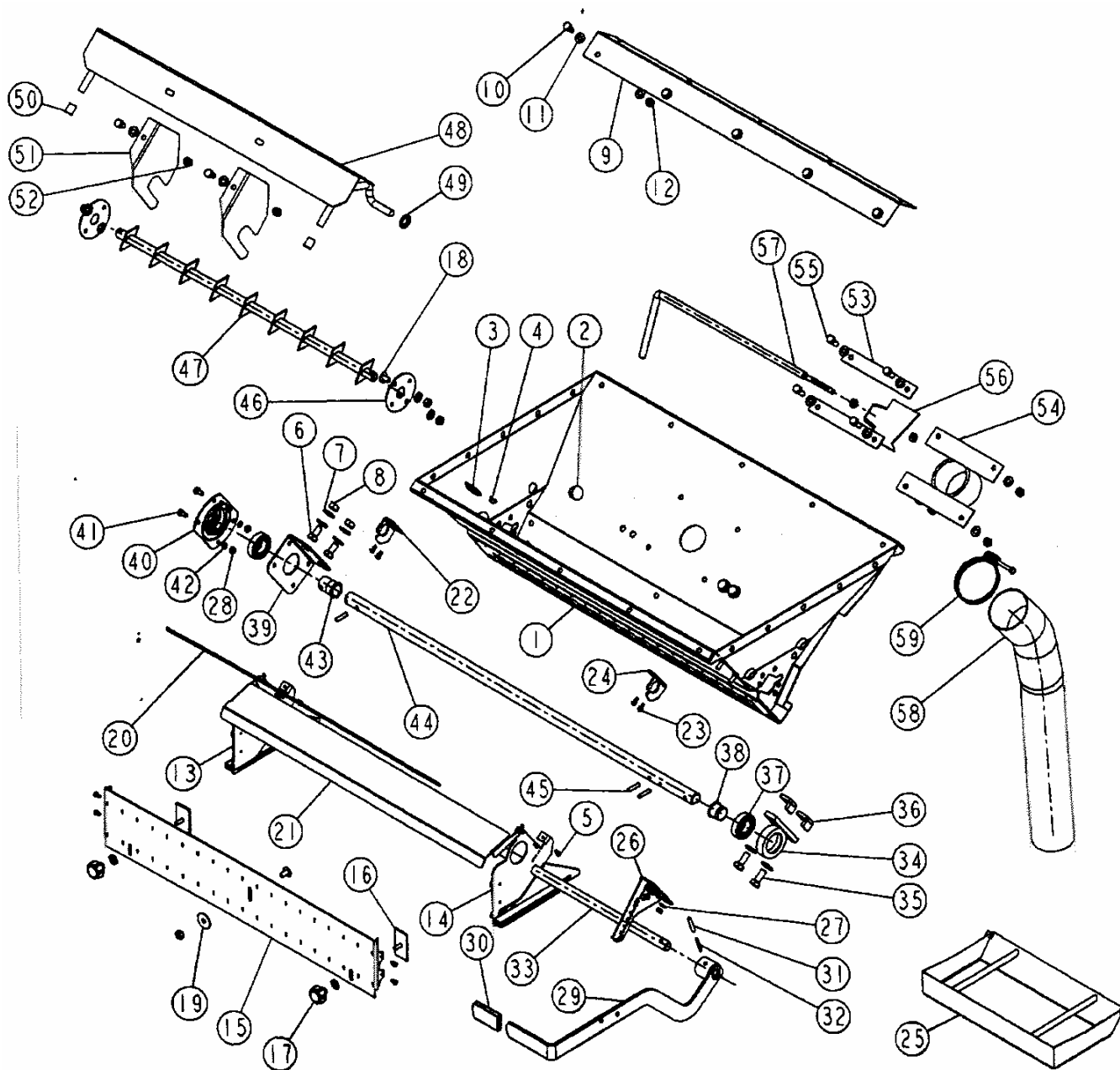

REP	CODE	DÉSIGNATION
1	1191007	Fond de tremie 18rgs so
2	415740	Bouchon d20 sr1011 12793
3	415721	Bouchon d29 kapsto gpn300 f24
4	415716	Bouchon d9 gpn 300 f041 nat
5	598041	Rivet aveugle 4x10 alu
6	552070	Vis h 10x20 zn 6 c fe
7	573109	Rondelle m10 n zn 6 c fe
8	571210	Ecrou h10 zn 6 c fe
9	997570	Tole de fixation 2 fonds uw
10	551865	Vis h 8x15 zn 6 c fe fst
11	573158	Rondelle m8n zn 6 c fe
12	571208	Ecrou h8 zn 6 c fe
13	1191049	Boitier extérieur q so
14	1191050	Boitier extérieur d so
15	997568	Tole de fermeture 18 dist
16	1191051	Verrou d entonnoir so
17	910688	Poignee de cmde h6 inox
18	535853	Vis trf 8x16 zn 6 c fe
19	573258	Rondelle 1l8 n zn 6 c fe
20	993217	Axe de fixation ressort 18 dist
21	997691	Tole anti-rebond 18 dist
22	962045	Retenue auget droit ps
23	598141	Rivet aveugle inox 4x12
24	962044	Retenue auget gauche ps
25	1191042	Auget uw so
26	989003	Secteur de clapet sp
27	573107	Rondelle m6 n zn 6 c fe
28	571206	Ecrou h6 zn 6 c fe
29	918144	Levier de sabot sp so
30	415750	Poignee k 28x5x60 noir
31	590307	Goup elastic 6x35 serie ep
32	589108	Goup elastic 3 5x36 serie ep
33	993218	Arbre de sabots 18 dist
34	914081	Palier so
35	552078	Vis h 10x25 zn 6 c fe fst
36	998184	Ecrou palier ext
37	711008	Roulement 6005 2rs1 25x47x12
38	931038	Palier court ergot
39	951232	Equerre palier ergot ps
40	924017	Palier tambour menant
41	551662	Vis h 6x12 zn 6 c fe fst
42	573356	Rond even dec az m6 zn 6cfe
43	998517	Arret de l arbre d ergot
44	993220	Arbre d ergot 18 dist
45	590306	Goup elastic 6x28 serie ep
46	992321	Plaque bouchon axe agitateur
47	1191008	Agitateur 18 distributions so
48	1191010	Toit anti-tassement 18 dist so
49	573612	Rond griffes d12 z5p
50	415731	Bouchon d12 sr1024 12760
51	997605	Tole de separation
52	571458	Ecrou frein h8 zn 6 c fe
53	996424	Cale de trappe de vidange
54	1191044	Glissiere trappe de vidange so
55	551870	Vis h 8x20 zn 6 c fe 8 8 fst
56	997619	Trappe de vidange uw
57	1191091	Tige de trappe de vidange so
58	720358	Tuyau d 75 l 1000
59	720358	Collier double fils diam 80



Ne pas démonter les pièces internes du variateur.
Do not dismount the variator's internal parts.
Die werksseitig eingebauten,
inneren teile dürfen nicht abmontiert werden.

①

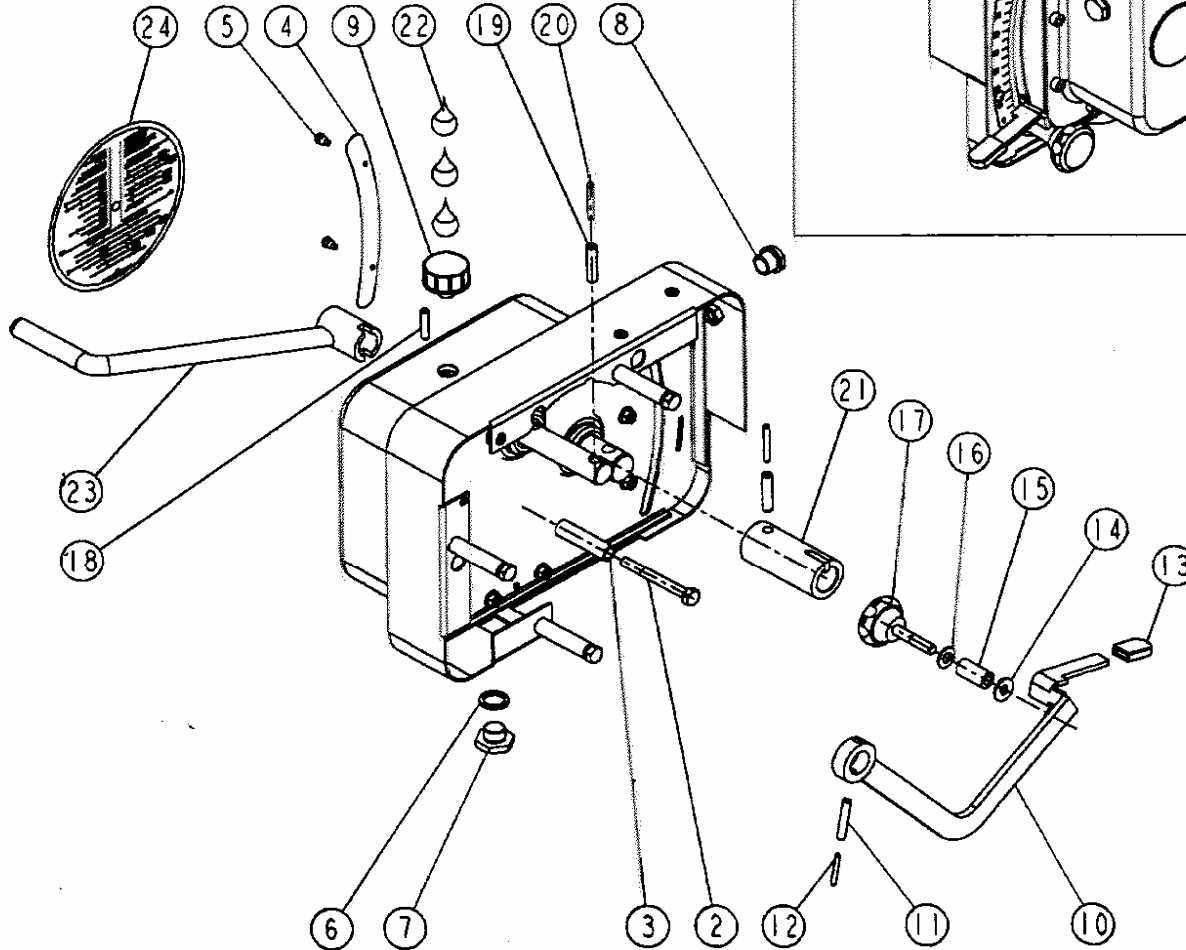
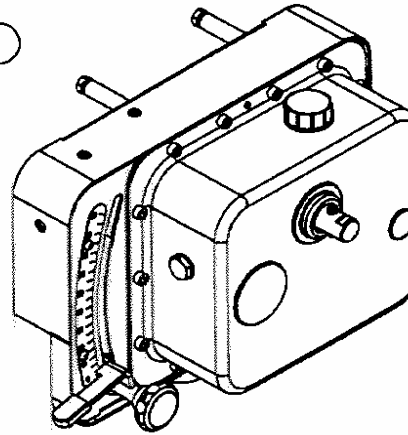

REP	CODE	DÉSIGNATION
1	910685	Variateur unidril-w mo
2	551920	Vis h 8x70 zn 6 c fe fp
3	992045	Entretoise de variateur
4	989002	Vernier d de variateur
5	598041	Rivet aveugle 4x10 alu
6	737003	Joint cuivre ferme 17x23x2
7	984008	Bouchon de vidange 3 8 gaz
8	795070	Temoin d huile 3 8 gaz
9	795060	Reniflard 3 8 gaz variateur
10	915012	Levier de variateur d so
11	590307	Goup elastic 6x35 serie ep
12	590106	Goup elastic 3 5x28 serie ep
13	415749	Poignee k 14x4x25 noir
14	573260	Rondelle polyamide 8x20x2
15	925027	Cale de levier
16	573158	Rondelle m8n zn 6 c fe
17	910296	Poignee de cmde h8x45 inox
18	590306	Goup elastic 6x28 serie ep
19	590407	Goup elastic 8x35 serie ep
20	590207	Goup elastic 5x35 serie ep
21	915138	Noix de distribution uw so
22	480002	Huile fluide atx 1 litre
23	916148	Manivelle 2
24	989017	Reglette debit semoir

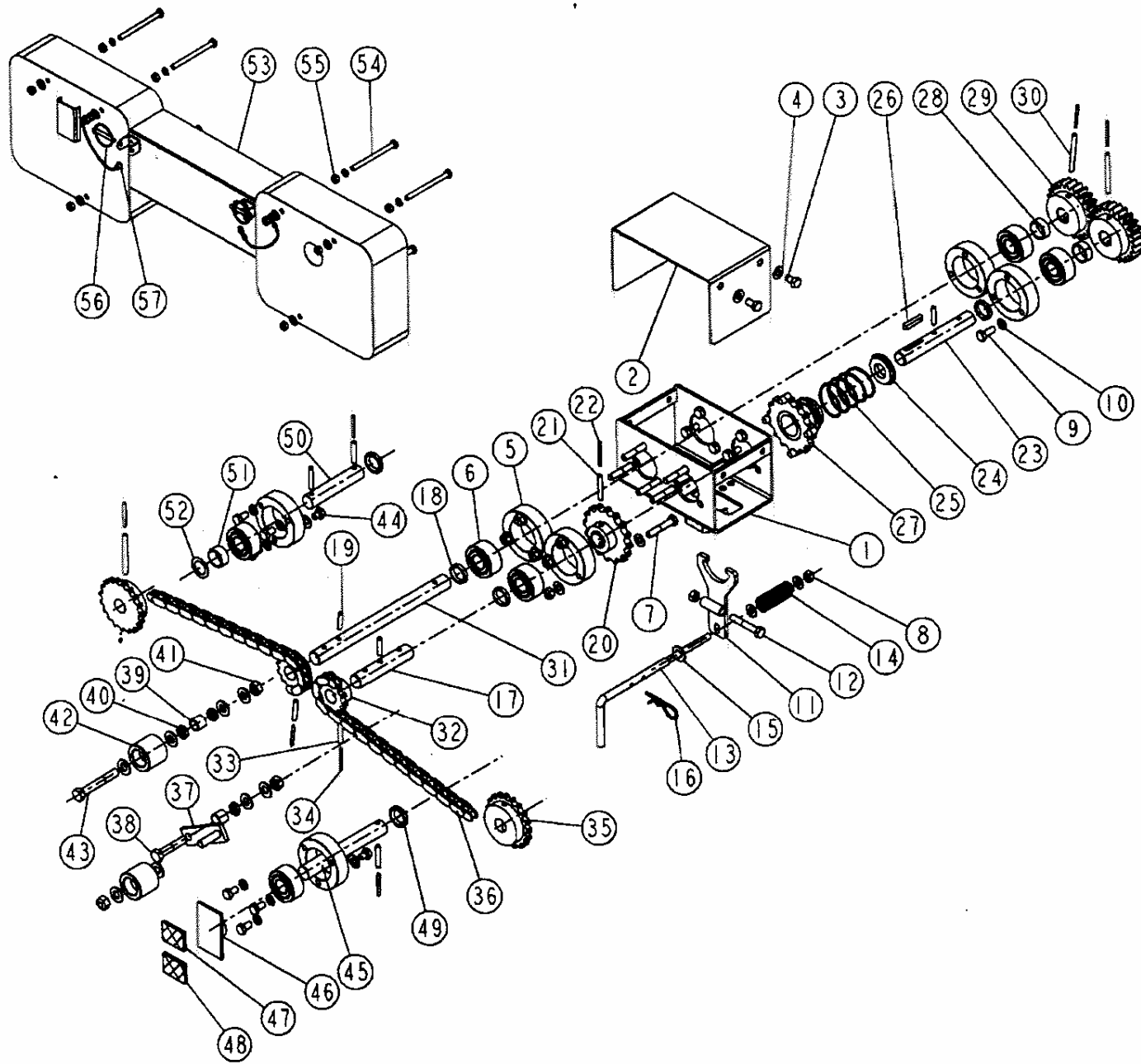

REP	CODE	DÉSIGNATION
1	1091765	Embase de débrayage uw so
2	997529	Carter embrayage uw
3	551865	Vis h 8x15 zn 6 c fe fst
4	573158	Rondelle m8 n zn 6 c fe
5	992046	Palier taraude uw
6	720348	Roulement 5204 2rs 20x47x20 6
7	551845	Vis h 8x45 fst
8	571408	Ecrou frein nylon h8 inox a2 70
9	551870	Vis h 8x20 zn 6 c fe 8 8 fst
10		Rondelle w d8 zn 6 c fe
11	1091766	Fourchette uw so
12	551900	Vis h 8x50 zn 6 c fe fp
13	1091991	Cmdr manuelle demie dist uw so
14	720350	Ressort 2-2x18-5x55x12-75
15	573109	Rondelle m10 n zn 6 c fe
16	592201	Goupille beta d3 zn 6 c fe
17	992372	Arbre primaire d entree uw
18	992157	Tube transm bras de roue l 5
19	590306	Goup elastic 6x28 serie ep
20	993167	Pignon pas 15 875 16 dts uw
21	590308	Goup elastic 6x40 serie ep
22		Goup elastic 3 5x40 serie ep
23	992373	Arbre primaire de sortie uw
24	992067	Rondelle d arret uw
25	720349	Ressort 2-5x45x70x5
26	996026	Clavette forme a 6x6x35
27	1091055	Crabot uw so
28	992151	Entretoise de pignon 19 dents
29	993177	Engrenage 24 dents module 3-25
30	590313	Goup elastic 6x65 serie ep
31	992374	Arbre secondaire uw
32	993116	Pignon pas 12 7 12 dts
33	590307	Goup elastic 6x35 serie ep
34	589108	Goup elastic 3 5x36 serie ep
35	993171	Pignon pas 12 7 19 dts diam 20
36		Chaîne transmission av uw
37	991337	Tendeur de chaîne uw so
38	552100	Vis h 10x50 zn 6 c fe fp
39	905358	Entretoise de herse
40	571360	Ecrou hm 10 zn 6 c fe
41	571410	Ecrou frein nyl h10 inox a2 70
42	998031	Galet tendeur
43	552125	Vis h 10x70 6 c fe 8 8 fp
44	551860	Vis h 8x10 zn 6 c fe
45	993237	Axe d agitateur av g uw
46	1191143	Support catadioptr uw so
47	720353	Catadioptr rouge 40x30
48	720352	Catadioptr blanc 40x30
49	734001	Joint v ring d20
50	993199	Axe d agitateur av d uw
51	992240	Tube transm bras de roue l 12
52	720351	Rondelle plate aluminium diam20
53	1091787	Carter cote opp variateur uw so
54		Vis h 8x100 zn 6 c fe fst
55	571208	Ecrou h8 zn 6 c fe
56	594306	Goup d6 clips zn 6 c fe s37
57	715010	Lien noir s29150 ref 715010

W Seed box half width shut off

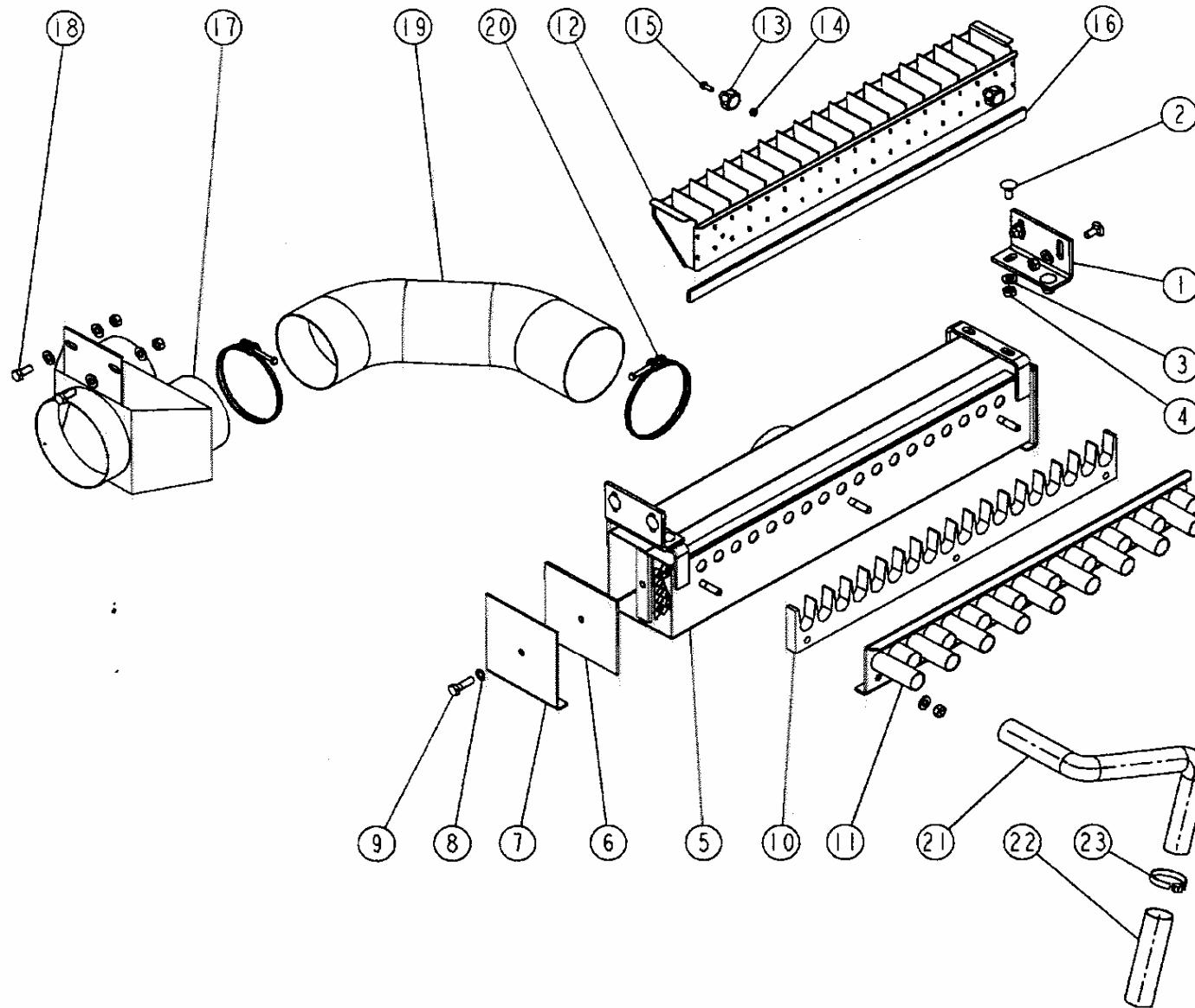

REP	CODE	DÉSIGNATION
1	996034	Support réglage caisson d'air
2	558975	Vis troc 10x25 inox a2 70 fst
3	573109	Rondelle m10 n zn 6 c fe
4	571460	Ecrou frein h10 zn 6 c fe
5	1191012	Caisson d'air 18 dist so
6	998098	Etanchéité de trappe de caisson
7	997213	Trappe de caisson d'air
8	573310	Rond éventail dec az m10
9	552085	Vis h 10x35 zn 6 c fe fst
10	997579	Injecteur monobloc 18 dist
11	1191014	Tôle support tuyaux 18 dist so
12	1191013	Entonnoir 18 dist so
13	415725	Bouton h6
14	571256	Ecrou h6 inox a2 70
15	541616	Vis h 6x16 zn 6 c fe 8 8 fst
16	794021	Bande adhésif 1 face l 0m70
17	1091853	Sortie double diam 125 so
18	552076	Vis h 10x25 zn 6 c fe fst
19	720359	Tuyau d 125 l 1000
20	720357	Collier double fits diam 125
21	793008	Tuyau d 30 l 1000
22	687118	Tuyau d 38 l 1000
23	684600	Collier serflex 32x52 l 8 mm

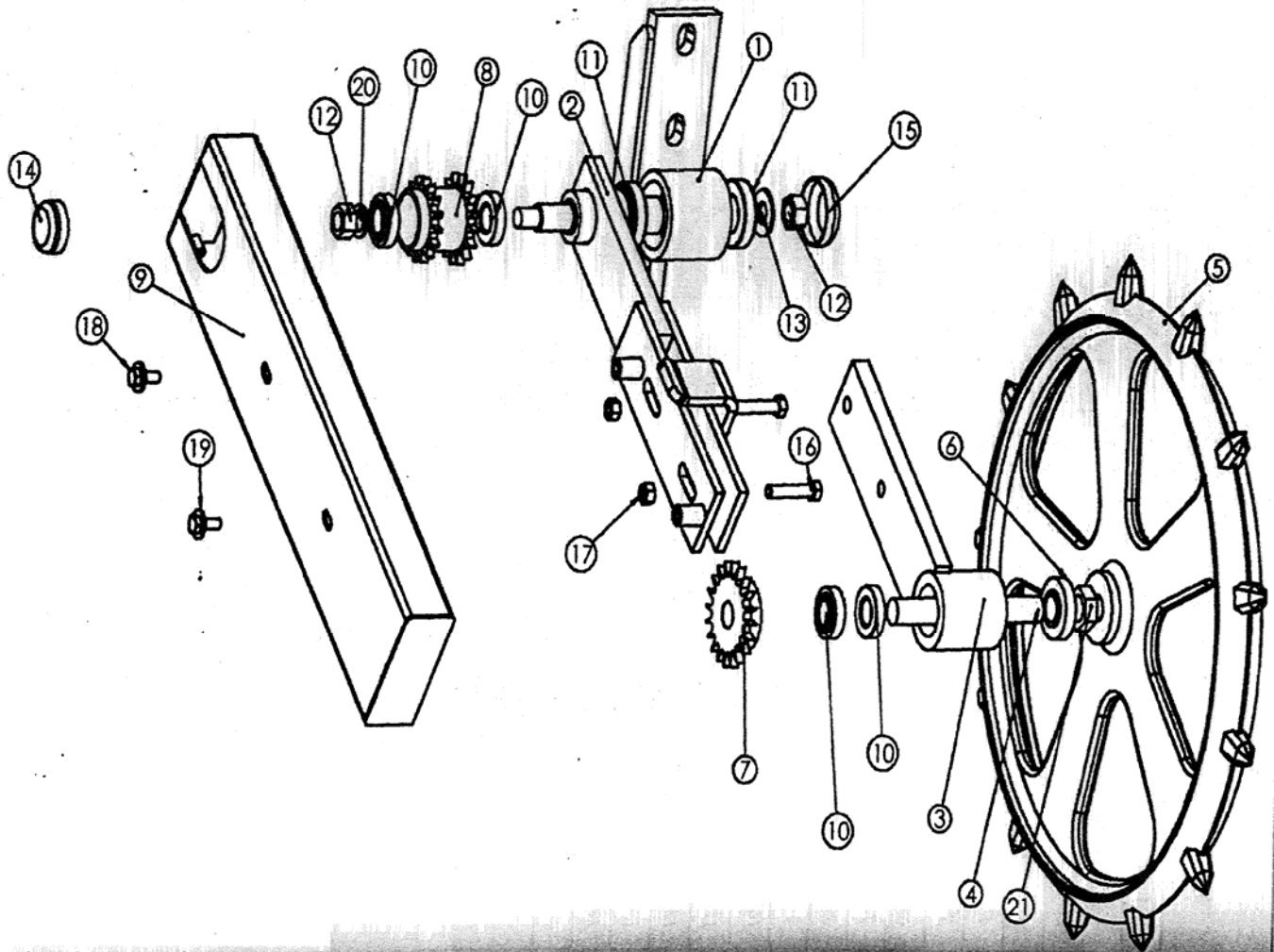

ITEM	PART No:	DESCRIPTION
1	W6.701A	Support Arm - Pivot Bracket
2	W6.702A	Drive Wheel Support Arm - Upper
3	W6.703A	Drive Wheel Support Arm - Lower
4	3.106	Drive Wheel Axle
5	3.112	Drive Wheel
6	3.108	Bearing Pivot Collar
7	S900596	20 Tooth Sprocket
8	S900594	16 Tooth Double Sprocket
9	W6.704A	Lower Drive Wheel Guard
10	A157N	1" Timken Duo Seal Bearing
11	A156	1 3/8" Timken Taper Roller Bearing
12	A132	3/4" UNF Locknut
13	319-1234	Bearing Pivot Washer
14	A182	Small Dust Cap
15	A183	Large Dust Cap
16	A111	M12 x 55 Bolt
17	A138	M12 Nyloc
18	A263	M10 X 25 Setscrew
19	A148	3/8" Spring Washer
20	A145	M20 x 32 H.D. Washer
21	A130	1" UNC Nut

W Seed box Drive Wheel Assy

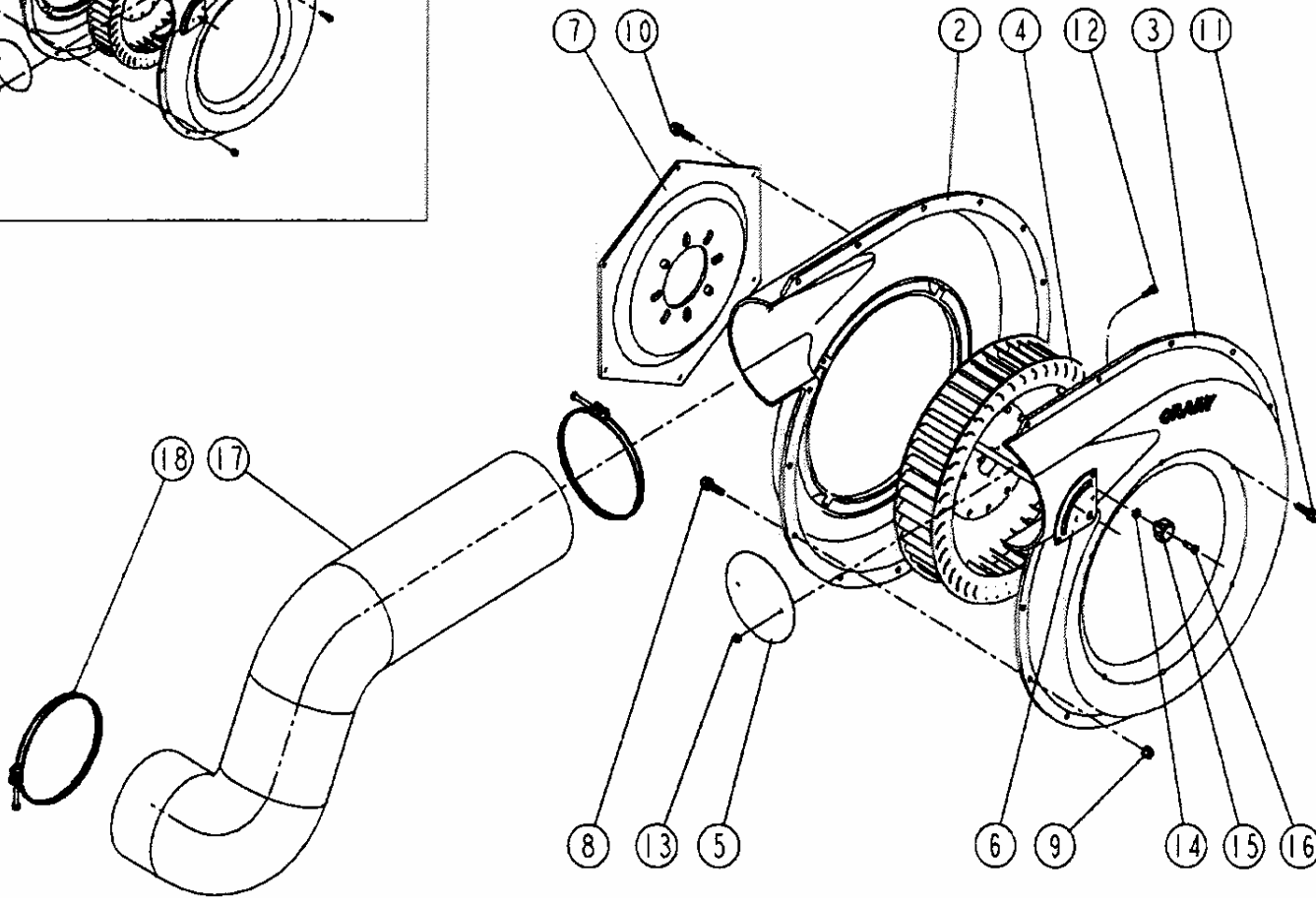
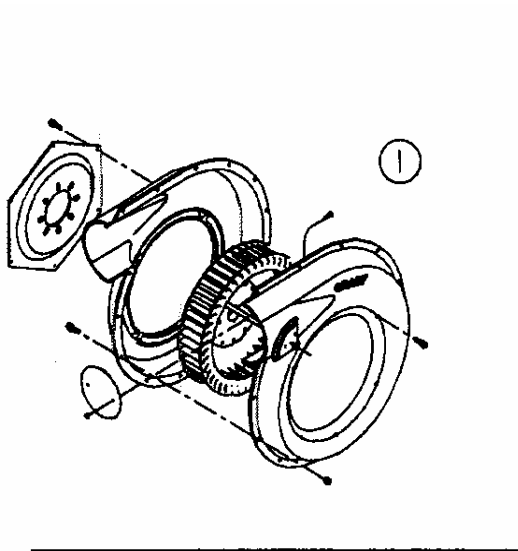

REP	CODE	DÉSIGNATION
1	912640	Turbine mécanique crary
2	720177	Coque d de turbine
3	720178	Coque g de turbine
4	720179	Roue a aube sens horaire
5	720187	Volet de turbine
6	720186	Secteur de volet de turbine
7	720182	Flasque support de turbine
8	720180	Vis a embase h 6x20 zn
9	720181	Ecrou serpress h 6 zn
10	720184	Vis auto-formeuse h 6x20 zn
11	720185	Vis auto-formeuse h 6x25 zn
12	720361	Vis 10-24 x 1 pouce gr5 hcps
13	720362	Ecrou 10-24 centerlock
14	573107	Rondelle m6 n zn 6 c fe
15	415725	Bouton h6
16	551680	Vis h 6x20 zn 6 c fe fp
17	683804	Tuyau d 160 l 1000
18	794542	Collier double fils diam 160

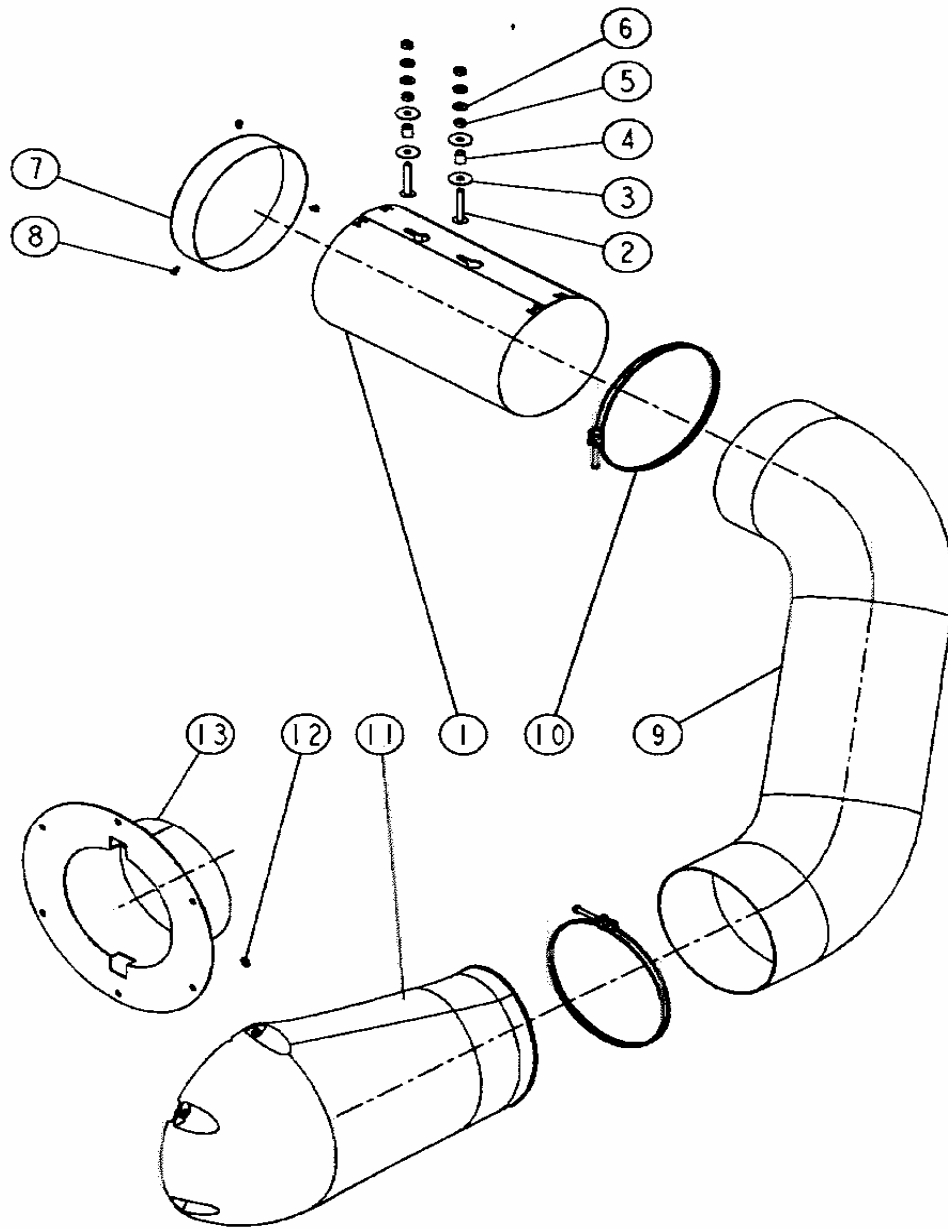

REP	CODE	DÉSIGNATION
1	976003	Filtre turbine
2	535861	Vis tri 8x50 zn 6 c fe 8-8
3	573258	Rondelle 1/8 n zn 6 c fe
4	901761	Articulation de biellette
5	571208	Ecrou h8 zn 6 c fe
6	573158	Rondelle m8n zn 6 c fe
7	415734	Bouchon d200 das 34183
8	598041	Rivet aveugle 4x10 alu
9	683810	Tuyau d 200 l 1000
10	794543	Collier double fils diam 200
11	985605	Goulotte aspiration
12	573107	Rondelle m6 n zn 6 c fe
13	918330	Goulotte aspiration w meca so

W Seed box Air Intake

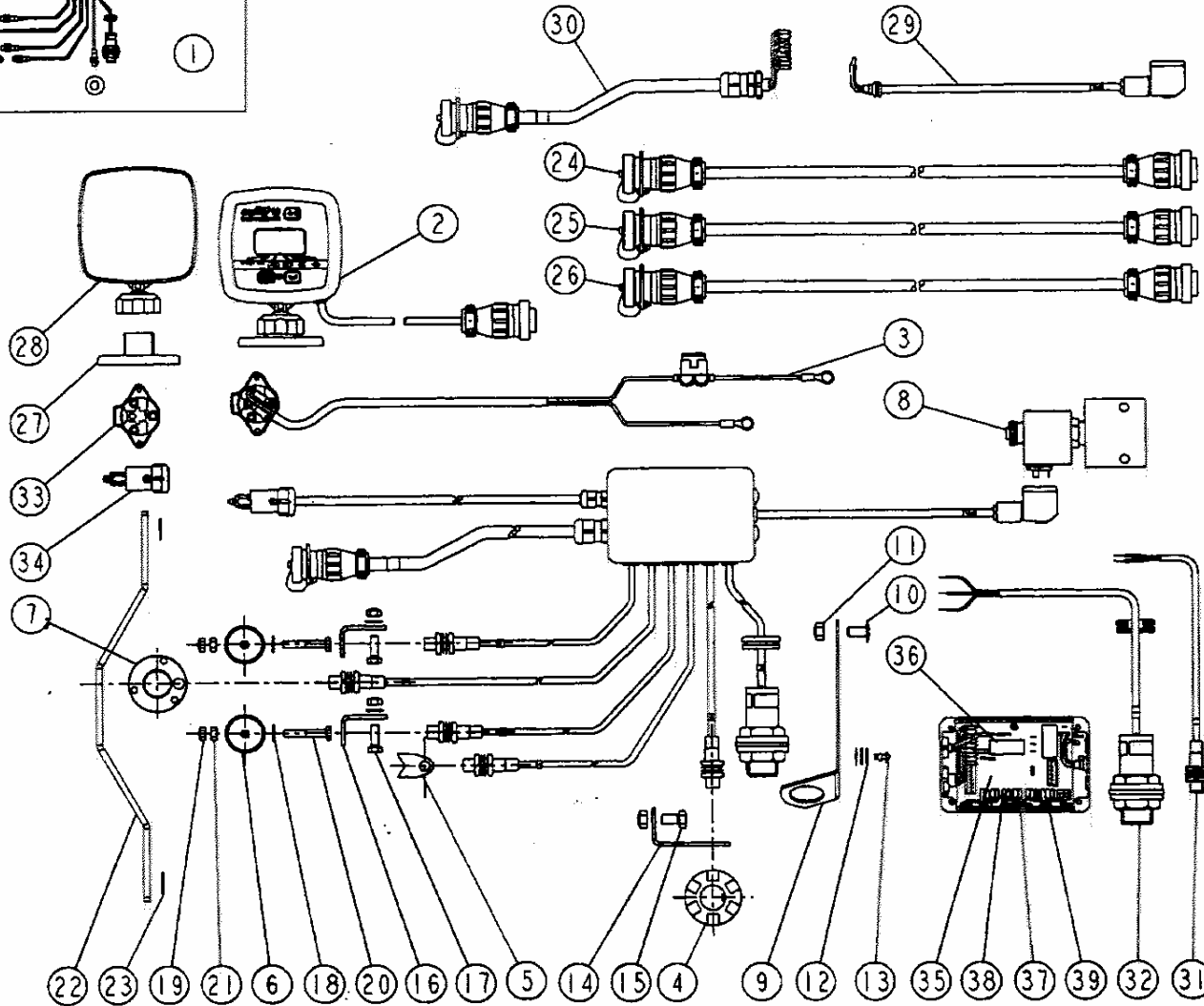
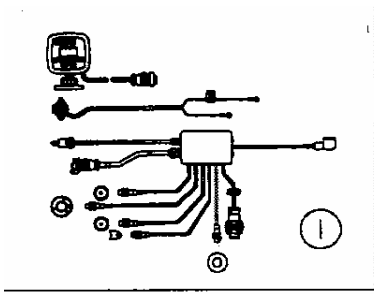

REF	CODE	DÉSIGNATION
1	983612	Boitier electro sulky-tronic ps
2	983606	Boitier sulky-tronic
3	983802	Faisceau d alimentation
4	983916	Aimant de distribution 6 plots
5	983915	Aimant a collier
6	983914	Aimant
7	720269	Aimant de turbine
8	795522	Electrovanne
9	942041	Equerre support jauge
10	535853	Vis trl 8x16 zn 6 c fe
11	571458	Ecrou frein h8 zn 6 c fe
12	573804	Rondelle l4 n inox a2 70
13	598041	Rivet aveugle 4x10 alu
14	996510	Support capteur dist uw
15	551865	Vis h 8x15 zn 6 c fe fst
16	962016	Equerre de toit
17	551680	Vis h 6x20 zn 6 c fe fp
18	573107	Rondelle m6 n zn 6 c fe
19	571406	Ecrou frein nylon h6 zn 6 c fe
20	551685	Vis h 6x35 zn 6 c fe
21	571206	Ecrou h6 zn 6 c fe
22	951239	Support capteur crary
23	573206	Rondelle l6 n zn 6 c fe
24	983619	Rallonge 4 metres sulky-tronic
25	983620	Rallonge 6 metres sulky-tronic
26	983621	Rallonge 9 metres sulky-tronic
27	951193	Socle de boitier electronique
28	962088	Boitier electronique nu
29	720401	Faisceau electrovanne 0m80
30	983805	Faisceau information tronic
31	983912	Capteur ils
32	983917	Capteur de niveau
33	983908	Prise alimentation femelle
34	983909	Prise alimentation male
35	720257	Circuit imprime sulky-tronic
36	720407	Relais sulky-tronic
37	720256	Boite de connexion avec circuit
38	720277	Connecteur 2 broches
39	720278	Connecteur 3 broches

UM_14_00

n° de série: ->

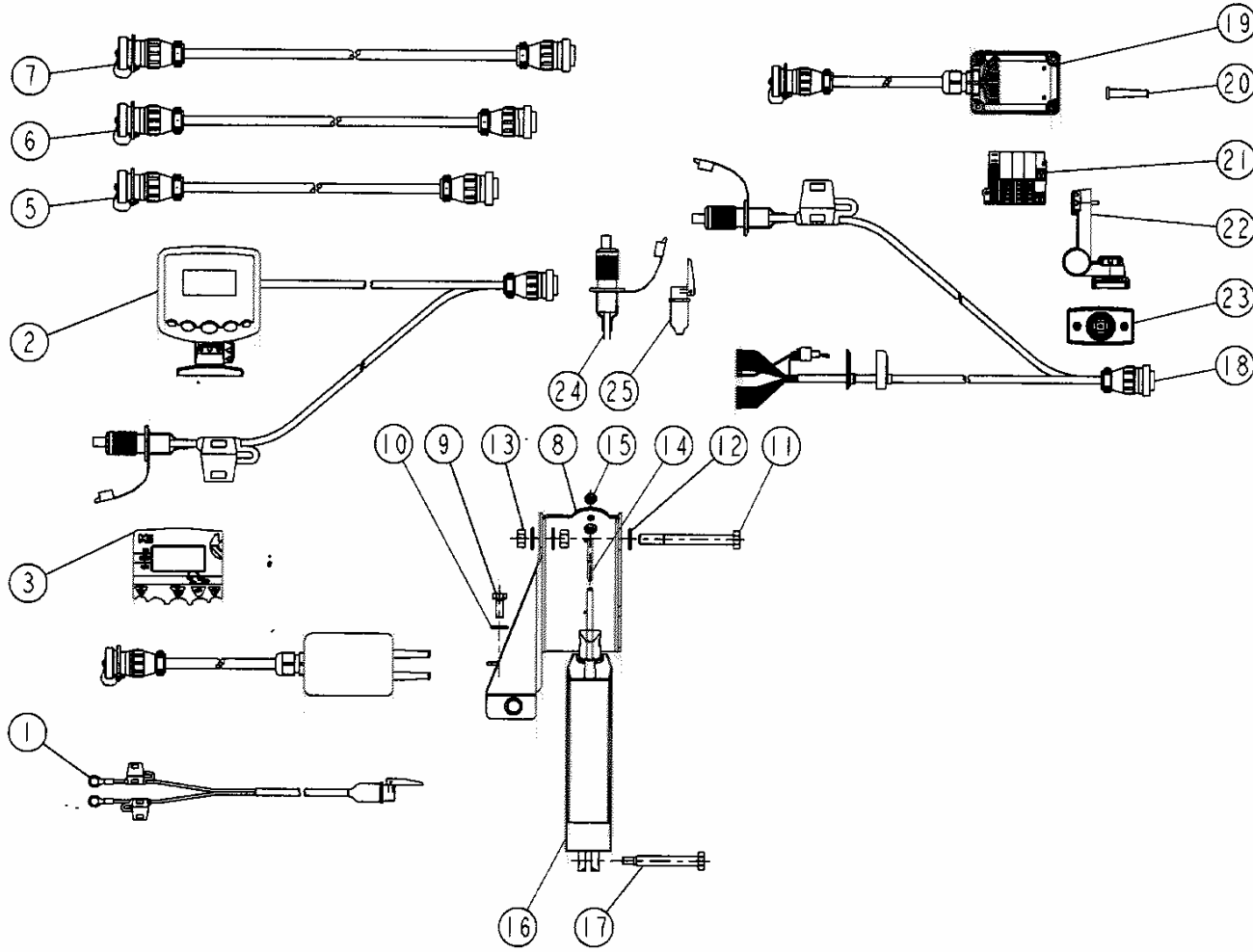

rep	code	COMMANDE_MS_SEMOIRS_RCH - 03-Nov-2005
1	983712	FAISCEAU_12_VOLTS_COBO
2	983632	CONSOLE_ULTRON_MS
3	983929	FACADE_MS
4	983635	BOITE_DE_CONNEXION_MS
5	983619	RALLONGE_ULTRON_4M_16_VOIES
6	983620	RALLONGE_ULTRON_6M_16_VOIES
7	983621	RALLONGE_ULTRON_9M_16_VOIES
8	951287	SUPPORT_VERIN_LINAK_VARIABLEUR
9	551870	VIS_H_8X20_ZN_6_C_FE_8_8_FST
10	573158	RONDILLE_M8_N_ZN_6_C_FE
11	552140	VIS_H_10X100_ZN_6_C_FE_8_8_FP
12	573109	RONDILLE_M10_N_ZN_6_C_FE
13	571210	ECROU_H10_ZN_6_C_FE
14	599056	VIS_A_OEILLET_M_6_X_40
15	571206	ECROU_H6_ZN_6_C_FE
16	982501	VERIN_ELECTRIQUE_DPB
17	921089	BROCHE_VERIN_LINAK_VARIABLEUR
18	720822	CABLE_INFO_CONSOLE_ULTRON_MS
19	720827	CABLE_INFO_MS_BOITE_CONNEX_NUE
20	720826	PASSE_FIL_ETROIT_ULTRON_MS
21	720828	CIRCUIT_IMPRIME_MS
22	720821	KIT_SUPPORT_CONSOLE_ULTRON_MS
23	720873	SOCLE_SUPPORT_CONSOLE_ULTRON_MS
24	720855	PRISE_MALE_12V_COBO
25	720854	PRISE_FEMELLE_12V_COBO