

# Moore

## 2.4 METRE ALL TILL SEED BED DRILL

BRITISH PATENT Nos. 1,218,785 1,591,607 2,040,656.  
U.S.A. PATENT Nos. 3,611,956 4,196,679. AUSTRALIA PATENT No. 518,030.  
CANADA PATENT No. 1,082,530, 1,121,660. NEW ZEALAND PATENT No. 192,436.  
SOUTH AFRICA PATENT No. 79/6679. OTHER PATENTS PENDING.

## Instruction Manual & Parts List.

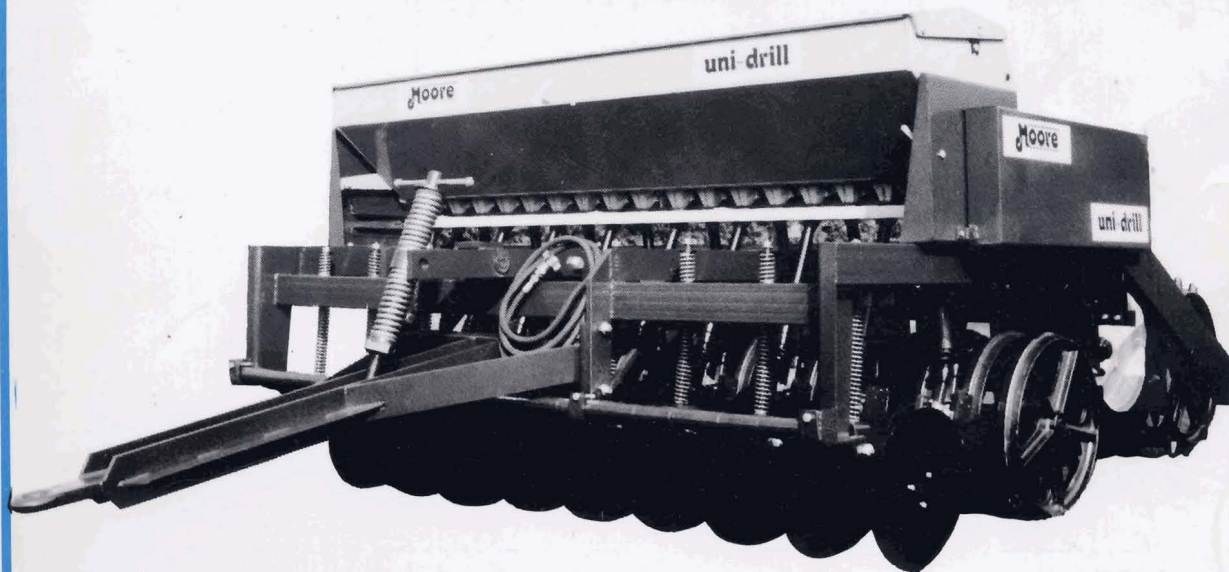

# Moore Uni-drill Ltd.

NEWHILL HOUSE, 33 KIRK ROAD, BALLYMONEY BT53 6PP, CO. ANTRIM,  
N. IRELAND. TELEPHONE: BALLYMONEY (STD 02656) 64444

## APPROXIMATE SEEDING RATES FOR MOORE ALL TILL SEED BED DRILL

### 2.4 M

CALIBRATION SCALE READING	SOWING RATES LBS./ACRE									
	ITALIAN RYEGRASS (COARSE)		GRASS SEEDS MIXTURE (FINE)		CEREALS, WHEAT, BARLEY OATS, RYE		LARGE SEEDS PEAS, SOYA BEANS		SMALL SEEDS TURNIPS, KALE RAPE, ALFAFA	
	21T	34T	21T	34T	21T	34T	21T	34T	21T	34T
2										2
3										5
4										11
5										22
6										40
7										
8				10		20				
9				14		35				
10				20		50				
11				27		65				
12	9			35		85				
13	11			45		105		70		
14	14			56		125		85		
15	17			64		150		110		
16	20			76		175		135		
17	23					205		165		
18	27					240		190		
19	31					280		230		
20	36							270		
21	42									
22	48									

**NOTE:** This Seed Chart is not a guarantee of the correct amount of seed to be sown - use it only as a guide for the seed quantities required.

Correct seed rates can be obtained by actuating the Acremeter as follows:

AREA	ACTUATIONS OF ACREMETER.	TURNS OF HANDLE ON SEEDBOX
One tenth acre	100	43
one twentieth hectare	125	53

Weigh the seeds in the collection trays provided. The weight of the seed is equivalent to that used to sow one tenth of an acre.

By adjusting the Micrometer Control Screw, the rate can be varied and the desired seed rate obtained.

**FIGURE A: MINIMUM PENETRATION**  
Drill with all the weight on the press  
wheel rollers —  
Disc seed coulters not touching ground

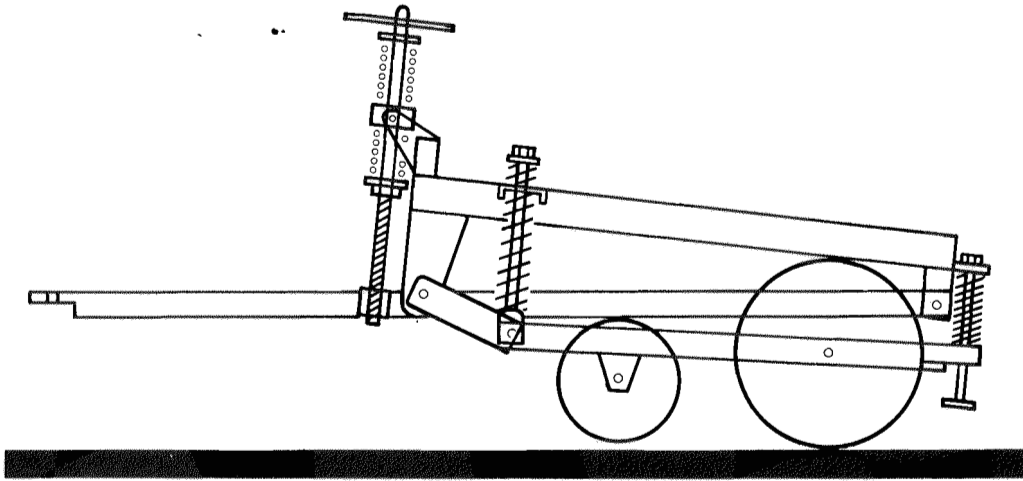

ALSO WINNER OF THE BURKE TROPHY FOR THE MACHINE OF  
OUTSTANDING MERIT AT  
THE ROYAL AGRICULTURAL SOCIETY OF ENGLAND SHOW 1976

**FIGURE B: MAXIMUM PENETRATION**  
Drill with all the weight on the disc  
seed coulters —  
Press wheel rollers not touching ground

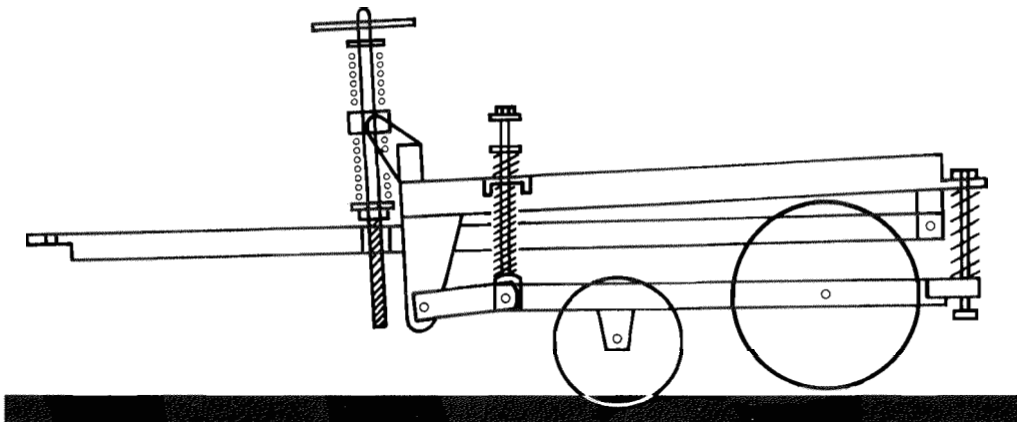

**FIGURE 1 DRAG ARM SEEDING UNIT**

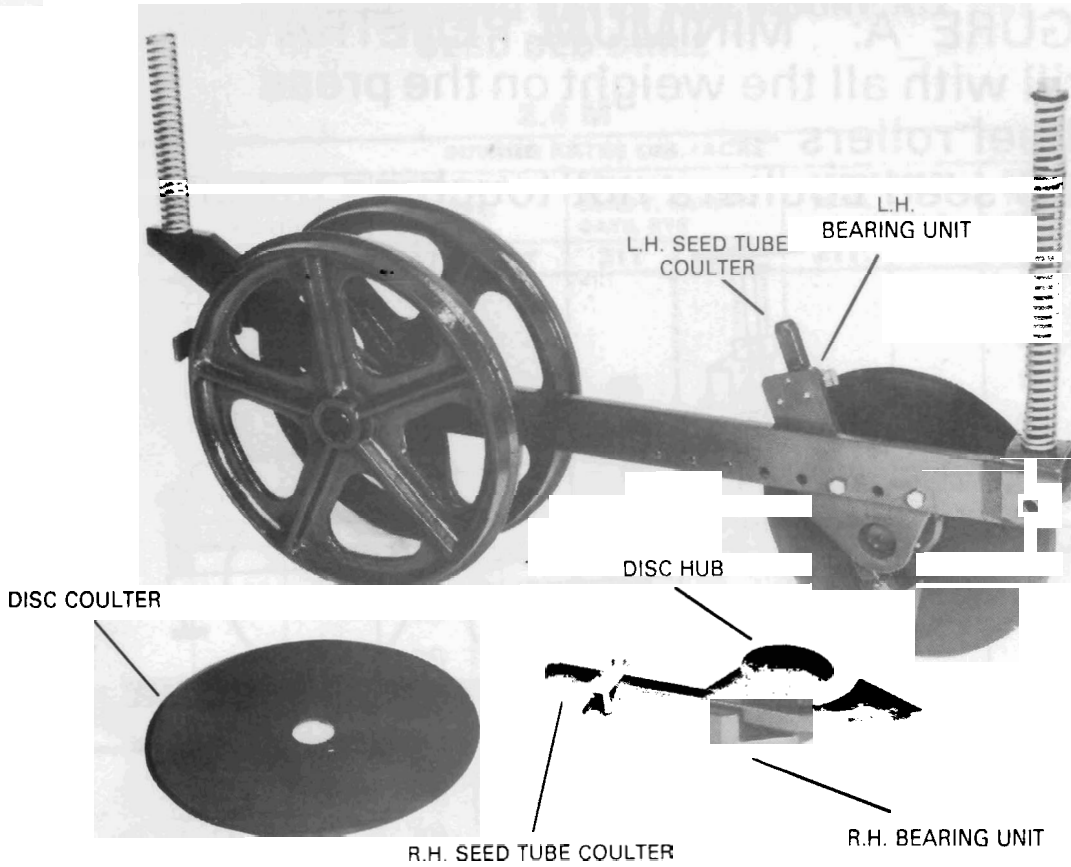

**FIGURE 2 SEED DISTRIBUTION AND CALIBRATION UNITS**

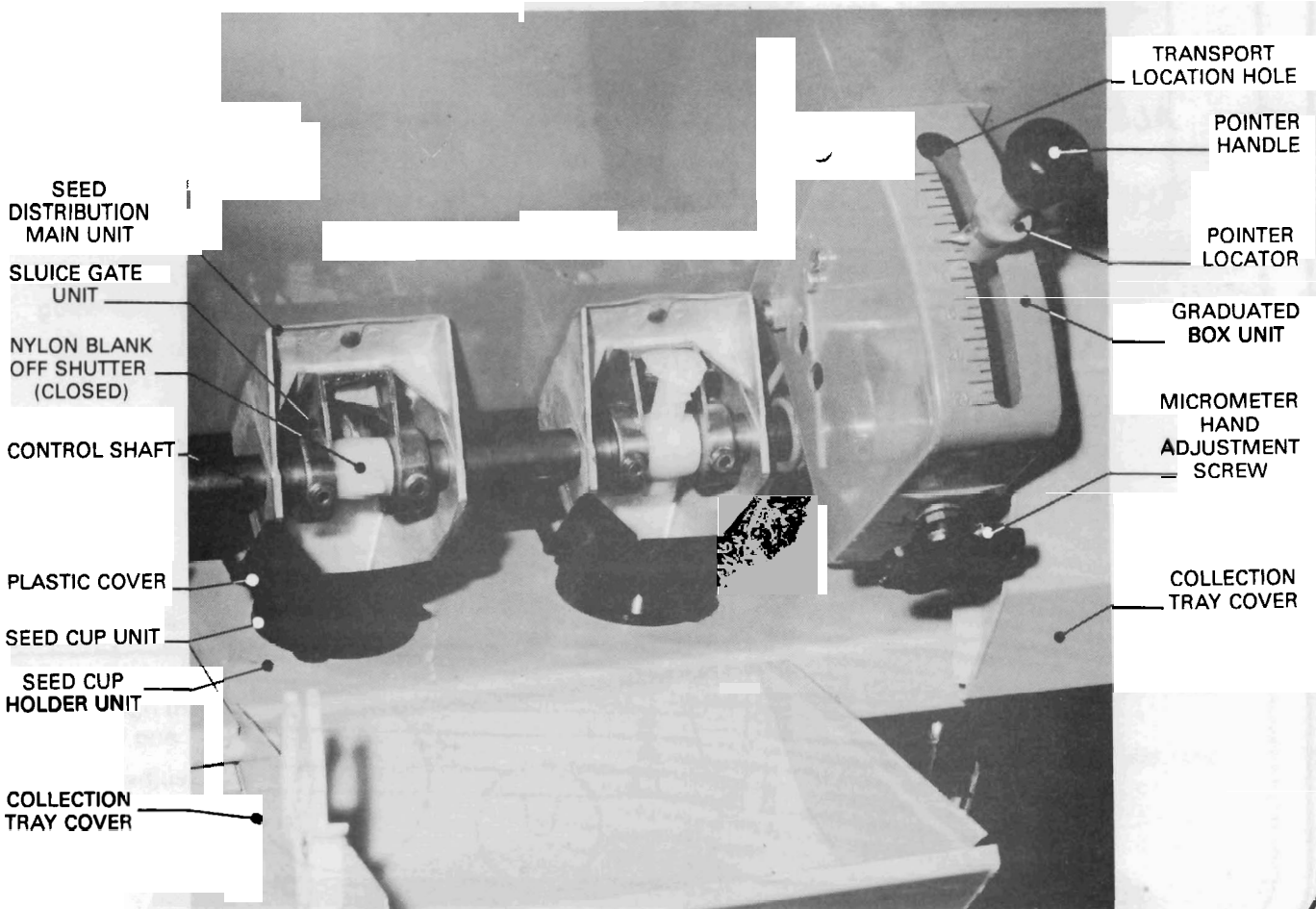

## 1. DESCRIPTION

The All-Till seedbed drills will sow most seeds into a variety of seedbeds. They can be used for conventional seedbeds with remarkable accuracy of depth of seed placement, also they can be used in minimum tillage, scratch tillage, direct drilling or no-till situations. The unique high inertia coulter system, with press wheel, maintains constant depth of seed placement under such a variety of conditions, including trashy and straw incorporated soils, at higher speeds than most drills can accommodate.

The All-Till seedbed drills consists of a row of independent drag arm seeding units which are spring mounted to the main frame. Each unit consists of 2 discs and 2 press wheel rollers, - the discs are mounted each side of the drag arm at opposite angles. A seed tube coulter is mounted on the inside of each disc, in a position which enables the seed to be placed in a slit cut by the disc.

The press wheel rollers are mounted to the rear of the drag arms behind the discs, rolling directly over the slits.

## 2. SPECIFICATION

Sowing Width	7ft.11 ins.	2400mm
Overall Width	8ft.2 ins.	2500mm
Total Weight	4300lbs.	2050Kg.
No. of Coulters	18	18
Row Width	5¼ in.	133mm
Seedbox Capacity	11 cu.ft.	310 litres

## 3. WORKING PRINCIPLE

When the drill is in the raised position, the weight of the machine is carried on the two land wheels and the tractor drawbar. As the machine is lowered, the disc coulters and press wheels touch the ground, meet resistance from the soil, and begin to compress the springs attached to each end of the drag arm seeding units - the frame can be lowered until all the available weight of the machine is supported on the springs.

The penetration of the discs and hence the seed depth is controlled by the depth adjusting screw. This alters the relationship between the discs and the roller press wheels; weight can be transferred from the rollers to the discs or vice-versa (*See Figs A and B*). As each drag arm is separately sprung both front and back, each unit is able to follow ground contours independently. As the drill is drawn forward, the inclined disc opens a slit and the seed tube coulter acts like a tine to prepare a tilth into which the seeds are dropped. The roller press wheels then consolidate to ensure good seed/soil contact and moisture retention.

## 4. TRANSPORT

The drill is raised and lowered hydraulically and locking pins are provided for road transport. When the drill is in work the tractor hydraulic control valve should be in the fully floating position so that the road wheels may ride freely over undulating ground conditions.

A double acting hydraulic ram is fitted to the drill. To raise the road wheels completely from the ground when the drill is in work, a second hydraulic hose can be fitted. Both hydraulic hoses should be connected to the spool valve on the tractor. Always keep the road wheels fully raised while the drill is in work, so as not to affect the depth control of the drill in undulating fields.

For transportation or moving the drill from field to field always ensure that the road transport pins are fitted. Also, the seed distribution units can be closed by pushing the pointer handle to the top of the graduation scale. It can be locked in this position by dropping the locator into the transport location hole.

## 5. DEPTH CONTROL

This is achieved by turning the depth adjusting screw to raise or lower the discs to the required depth in different field conditions and seed requirements; turning the screw clockwise increases depth, while turning the screw anti-clockwise reduces the depth. Care must be taken with this setting to achieve correct seed depth and effective pressing with the rear press wheels.

## 6. SEEDBOX (See Figs. 2 and 3)

Each seed distribution unit of the Moore All-Till Seedbed Drills is supplied with seed from the hopper by means of a seed feed box. The variable opening of the distribution unit regulates the seed rate. At the lowest part of the feeding box, a plastic feed rotor, operated by the stalker drive wheel, supplies the distribution unit with seed at a high degree of uniformity. Made of flexible plastic (Lucolen) the feed rotor is adapted to, and fits the shape of all kinds of seed: large or small, heavy or light, round or long.

**FIGURE 3 SEEDBOX**

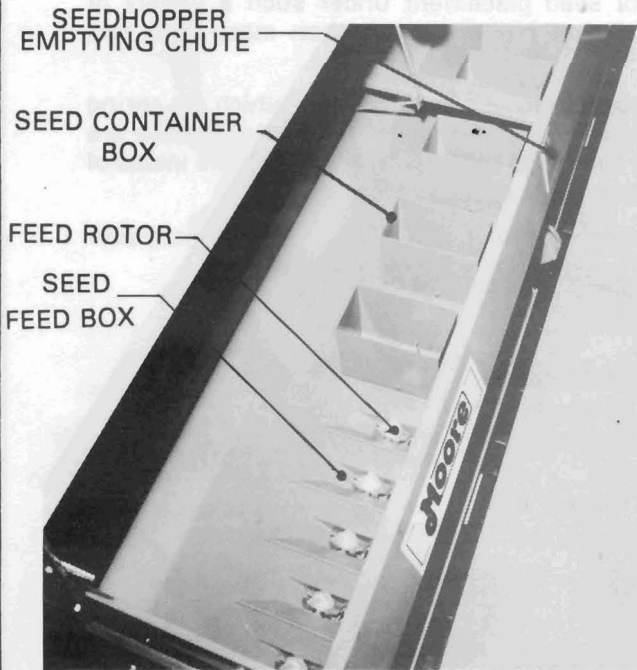

**FIGURE 4 EMPTYING SEED BOX**

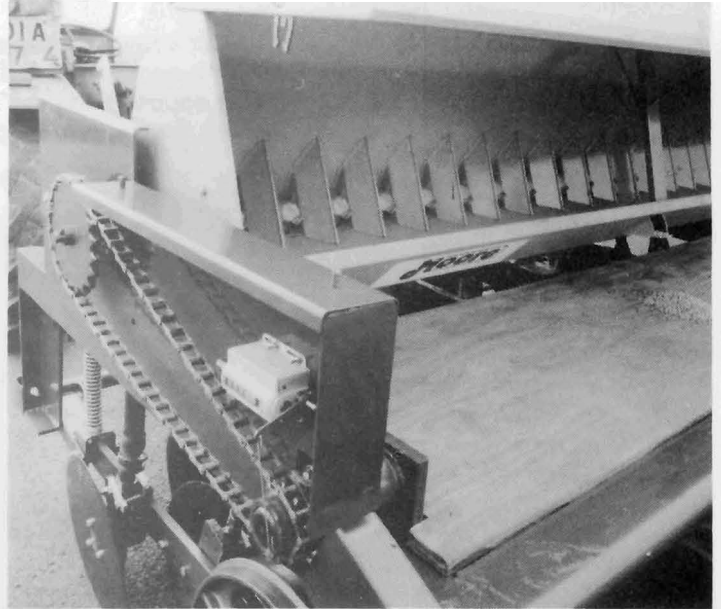

**FIGURE 5 CALIBRATION**



A micrometer hand control screw is used to adjust the openings of the seed distribution units for precise seed rate settings.

## **7. CALIBRATION (See Fig.5)**

The Seed Charts are not a guarantee of the correct amount of seed to be sown - use them only as a guide to the seed quantities required. Compilation of a Seed Rate Chart is not possible due to variations in seed types and seed mixtures. Also the type and quantity of seed dressings used.

*To check the Seed Rate, set the calibration pointer to the reading as given in the Seeding Tables:* open the covers protecting the distribution units and hinge them down to form collection trays for the seeds. Release the spring loaded locating pins at each end of the seed cup holder unit and slide it forward so that the seed collection trays are underneath the outlets of the seed distribution units.

Ensure that the handle is turned so that the drive wheel turns in the normal direction of travel.

Partially fill the seedbox and actuate the acremeter 100 times. 43 turns of the handle when attached to the 21 tooth seedbox sprocket.

Remove the collection trays and weigh the seed; this will represent the seed rate for one-tenth of an acre. Multiply by 10 to obtain the Seed Rate Per Acre. By adjusting the micrometer control screw the rate can be varied and the desired Seed Rate obtained.

## **8. SEEDING AT DIFFERENT ROW WIDTHS**

It is possible to sow seeds at row widths of 5¼ in. (13.3cms.), 10½ in., (26.6 cms.), 15¾ ins., (40 cms.), and 21 ins., (53.3cms.)

Blank off the seeding units not required by turning the nylon blank off shutters to close the openings of the seed distribution units, as shown in Fig.2.

For small seeds, such as kale, rape, turnips etc., seed container boxes can be securely mounted over the required seed feed boxes as shown in Fig. 3.

## **9. EMPTYING SEEDBOX (See Fig. 4)**

To empty the seedbox, remove the collection tray/covers. Release the seed cup holder unit and slide it fully forward. Slacken the screw and channel retaining bracket so that the seedbox fixing arm is free. Open the seedbox lid and secure with the stay bracket. Pivot the seedbox backwards as shown in Fig. 4. Open the seed hopper emptying chute and remove the seed into a tray or bag.

## **10. ACREMETER**

The acremeter is actuated by a linkarm attached to the end of the double drive sprocket. The adjustable arm on the end of the meter should be positioned so that the linkarm is free when the end of the crank is at the top of its stroke.

The acremeter is calibrated so that it takes 1000 actuations to read 1 acre, therefore, only the first 3 digits read the acres and the last 2 digits the decimal fraction of an acre.

The acremeter can be set to Zero by turning the ribbed knob on the end of the meter.

## **11. MAINTENANCE**

### **A. NUTS AND BOLTS**

All nuts and bolts should be checked regularly. When working in stony or trashy conditions it will be necessary to check all nuts and bolts daily, particularly the seed tube coulters and disc bolts.

### **B. BEARINGS**

Check disc and press wheel bearings for correct adjustment.

1" Dia. Timken Duo Seal Taper Roller Bearings are fitted to the press wheels and disc hubs on the drill.

Remove the dust cover and use a socket on the lock nut to tighten up the two taper roller bearings so that they can just turn freely. When the bearings are slack the rubber seals will wear thus allowing in dust, ending up with a dry bearing. The bearings are packed with Shell Alvania Grease.

## C. SEED TUBE COULTER ADJUSTMENT

Check the position of the seed tube coulters in relation to the disc coulters daily.

For most seeding conditions and as a general rule the tip F of the seed tube coulters should be set so that it is approximately  $\frac{1}{2}$  " above the outer edge of the disc. The leading edge of the seed coulters should be set parallel to the disc and just touching it. This can be achieved by means of the retaining bolts A and B and the adjusting screws C and D. If the tip, F, of the seed coulters is out from the disc, this can be corrected by tightening bolt A (front bolt) more than bolt B, while the top, G, of the seed coulters can be brought in towards the disc by tightening bolt B (rear bolt) more than bolt A.

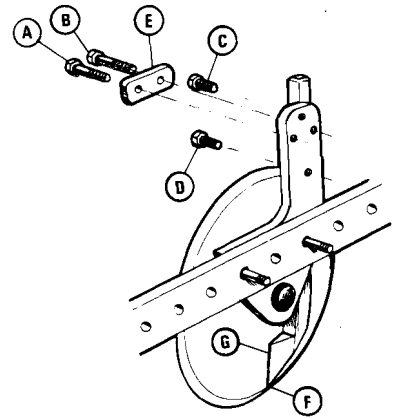

Some discs, may be slightly distorted, but when in work the side force of the soil on the disc will keep it in contact with seed coulters. A certain amount of bedding in and wear takes place between the disc and the seed coulters and it may become necessary to adjust screws C and D to position the seed coulters closer to the disc.

## 12. OPERATION OF ALL-TILL SEEDBED DRILLS

### A. PREPARATION AND CALIBRATION

Attach the drill to the tractor and raise the drill to its maximum height, remove the road transport pins.

Calibrate the seeding mechanism for seeds to be sown.

### B. RUNNING IN

If the drill is new and is to be used in cultivated soil, it is better to 'run-in' the drill in hard ground, such as a grass field. It is easier to work off the paint and rough edges from the seed tube and disc coulters when working in firm ground where there is more friction to turn the discs. This only requires a few runs across a field, without seed. The depth control of the All-Till seedbed drill can be tried out by turning the depth control screw up or down to increase or decrease the depth of disc penetration. Check that all the discs turn relatively freely; it may be necessary to slacken off seed tubes that are rubbing tight against the discs.

### C. FIELD OPERATION

Do not turn sharp corners with the All-Till seedbed drills, especially in direct drilling operations as this will give wrong disc-to-soil side thrust. When this happens the disc is parted from the seed coulters and trash can then enter between them resulting in blockage to the seed flow. It is better to lift the machine out of and into work when turning corners.

### D. WORK RATE

As there is no disc bounce, due to the high inertia coulters system with press wheels, relatively high ground speeds can be tolerated giving high work rates. The operating speed and the quality of work which results is controlled by field conditions but wherever possible a steady speed should be maintained. As field conditions vary, it may be necessary to adjust the coulters settings to maintain seed depth and cover.

### E. SEEDBED PREPARATION

It is not necessary to prepare a fine seedbed as for other drills. The All-Till seedbed drill prepares its own mini seedbed by using angled disc and seed tube coulters tine. In most fields it is only necessary to plough and perhaps level and roll. If the soils are loose, puffy, soft or have loose stones on the surface, it will generally be advantageous to roll the field first. This will reduce blockages and help maintain even depth control.

### F. DRILLING IN CONVENTIONAL SEEDBED

When working in cultivated soil, most of the drill weight is carried on the press wheel rollers and tractor drawbar. Seed depth can be obtained by adjusting the depth control screw in the usual manner. The soil is usually tracked to the depth required by the disc seeding units and compacted by the press wheel rollers - this gives ideal conditions for seed germination.

It is recommended that the centre of the field should be drilled first and the headlands last. If the headlands are planted first, then the tractor and drill will travel and turn on planted ground, thus disturbing, compacting and moving seeds that have been placed at a constant depth. Check seeding depth in the field and on headlands, remember the headlands tend to be more compacted than the remainder of the field.

On rough type seedbeds the drill itself tends to be self levelling. The seed tube and disc coulters units tend to move the soil from humps to hollows. It is not necessary to harrow and roll after sowing.



Harrowing will move seeds either shallower or deeper thus giving uneven germination. Remember seeds that are planted two to three inches deep take about two weeks longer to germinate and appear as weak plants, that are susceptible to disease.

#### G. DRILLING IN WET CONDITIONS

The All-Till seedbed drills are now fitted with adjustable scrapers for the press wheels. Wet soil will usually build up to about one inch on any wheel. Adjust the scrapers so as to knock off the excess soil that would build up over the normal amount of soil that sticks to the press wheels.

Never reverse the drill with the seed tube coulters in the ground as this would block the seed outlets with soil.

Where there are very wet pockets of soil in some fields, the road wheels can be used to slightly raise the drill out of the ground thus assisting the drill through the difficult areas. Be careful not to raise the drill too high; always keep the seed drive wheel in contact with the ground.

#### H. DRILLING INTO STRAW INCORPORATED SOIL AND TRASHY CONDITIONS

In heavy trash conditions it may be necessary to raise the tip of the seed tube coulters, so that the disc will cut through the trash before the coulter opens the slit. In heavy maize trash, especially in the direct drill or no-till situation, it may be necessary to raise the tip of the seed tube coulter 1" to 1½" above the edge of the disc.

The discs cut through the trash very positively. The weight of the press wheels keep the discs anchored and do not allow the discs to ride out of the soil, even when there is a lot of trash present.

Bulldozing normally occurs when a disc meets trash, tries to ride up over the trash, then pushes it in front of the disc, thus causing bulldozing and blockages.

The trash itself, on decaying, produces acids, toxins, etc., which tend to damage or kill the germinating seed. If the trash is mixed with the soil and compacted tightly to give good straw/soil contact then the soil will absorb the toxins as they are formed, before they can harm the germinating seedlings. The press wheels on the All-Till seedbed drills compacts the trash/soil/seed exactly right to give very healthy plant stands even in very trashy conditions.

If straw is incorporated into the soil to leave a loose fluffy seedbed then it is better to compact this first using either a roller, crumbler bar, flexicol, etc., before drilling.

#### I. MINIMUM TILLAGE AND DIRECT DRILLING

In certain soils, especially if they contain stone or brash, it is recommended that the top 1" or 2" should be cultivated or scratch tilled. This will encourage the germination of volunteer cereals and weed seeds. It will also help to level out the tramline and wheeled tracks. Also if stones are left undisturbed in the top layer, they become embeded and the disc will ride from stone to stone without getting good penetration.

In soft field conditions it is essential to set the discs deep enough to cut through all the matt or surface trash. Seed will germinate and grow better when in contact with the soil. In wet, soft conditions the discs may be set to penetrate deeper than required. As the drill moves forward the seed is trapped by the sides of the slit and do not necessarily fall to the bottom of the slit.

#### J. OTHER SUGGESTIONS

If no air line or vacuum is available to assist in the cleaning out of the seedbox, paper tissues can be used. Fully open the seed distribution units, wrap up a large paper tissue and place it between the rotor and seed feed box. Turn the rotor so that it will take the tissue around the bottom of the seed feed box wiping it clean.

With certain types of peas, beans, etc., the large seeds tend to catch between the rotor and bottom of the seed feed box, thus splitting and damaging the seeds. Some users keep and use a second set of rotors from which about ¼" has been cut off the end of the plastic rotors. With the shorter rotors, the large seeds will not jam between the rotor ends and the bottom of the seed feed box. Less power will be required to turn the drive wheel and less damage to the seeds will occur.

With small seeds such as oilseed rape, especially if they are covered with seed dressings, it is important to check the flow of seeds from the distribution units. The dressings, especially when damp, tend to build up around the openings like cement, reducing the size of the opening and thus the seed rate. A small nail as a length of wire can be used to clear the build up of the dressings.

# MAIN FRAME & DRAWBAR UNIT

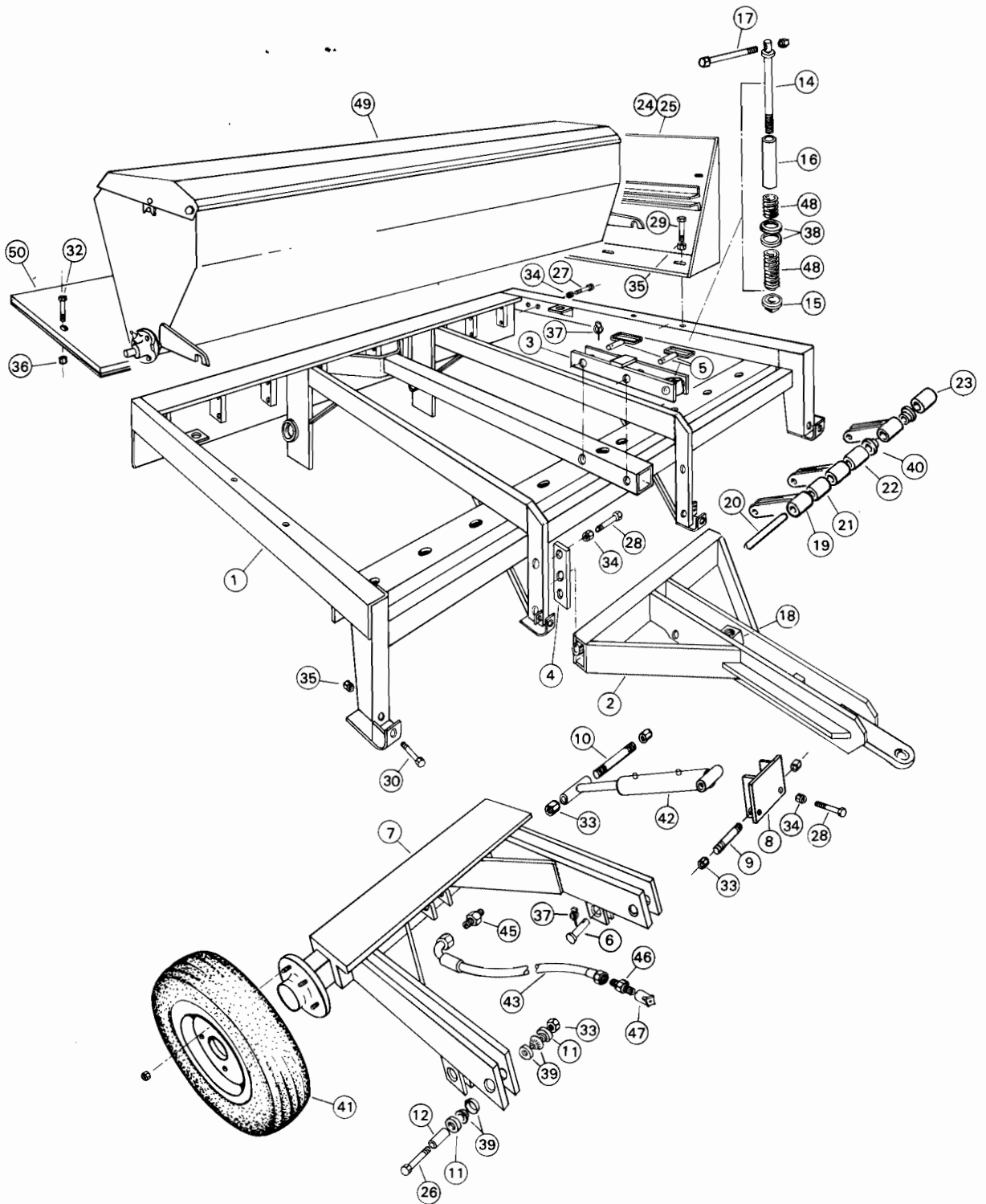

**MAIN FRAME & DRAWBAR UNIT**

<b>ITEM</b>	<b>PART NO.</b>	<b>DESCRIPTION</b>	<b>QTY.</b>
1	110-1000	Main Frame	1
2	120-1000	Drawbar Assembly	1
3	121-1000	Depth Control Screw Unit	1
4	122-1000	Drawbar Pivot Bracket	2
5	124-1000	Drawbar Pivot Pin	2
6	125-1034	Transport Pin	2
7	126-1000	Axle Mounting Unit	1
8	127-1034	Top Bracket - Ram	1
9	128-1034	Ram - Top Bolt	1
10	129-1034	Ram - Bottom Bolt	1
11	130-1034	Pivot Collar - Axle Unit	4
12	131-1034	Pivot Bush - Axle Unit	2
14	134-1234	Depth Control Screw	1
15	135-1234	Depth Control Screw - Nut	1
16	136-1234	Depth Control Screw - Tube	1
17	137-1234	Depth Control Screw - Handle	1
18	138-1234	Depth Control Screw - Trunnion	1
19	140-1234	Pivoting Arm Unit	9
20	141-1000	Front Pivot Bar	1
21	142-1000	Spacer Bush - Inner	6
22	143-1000	Spacer Bush - Inner Bushed	2
23	144-1000	Spacer Bush - End	2
24	310-1000	Seedbox Mounting Bracket - R.H.	1
25	311-1000	Seedbox Mounting Bracket - L.H.	1
26	A101	1" x 6" UNC Bolt	2
27	A105	M20 x 100 Bolt	2
28	A106	M20 x 70 Bolt	6
29	A108	M12 x 120	6
30	A109	M12 x 100 Bolt	4
32	A114	M10 x 50 Bolt	2
33	A130	1" UNC Locknut	6
34	A135	M20 Locknut	8
35	A138	M12 Locknut	10
36	A139	M10 Locknut	2
37	A152	Lynch Pin	4
38	A155	2" Timken Thrust Bearing	2
39	A156	1 3/8 " Timken Taper Roller Bearing	4
40	A159	Oilite Bush	24
41	A164	Road Wheel	2
42	A170	3" Dia. Hydraulic Cylinder	1
43	A171	Hydraulic Hose Ram Tractor	1
46	A174	3/8 B.S.P. Nipple	2
47	A176	Dowty Coupling	1
48	A185	Depth Control Spring	2
49	A201	Seed Box Complete	1
50	A291	Rear Platform	1

# DRAGARM SEEDING UNIT

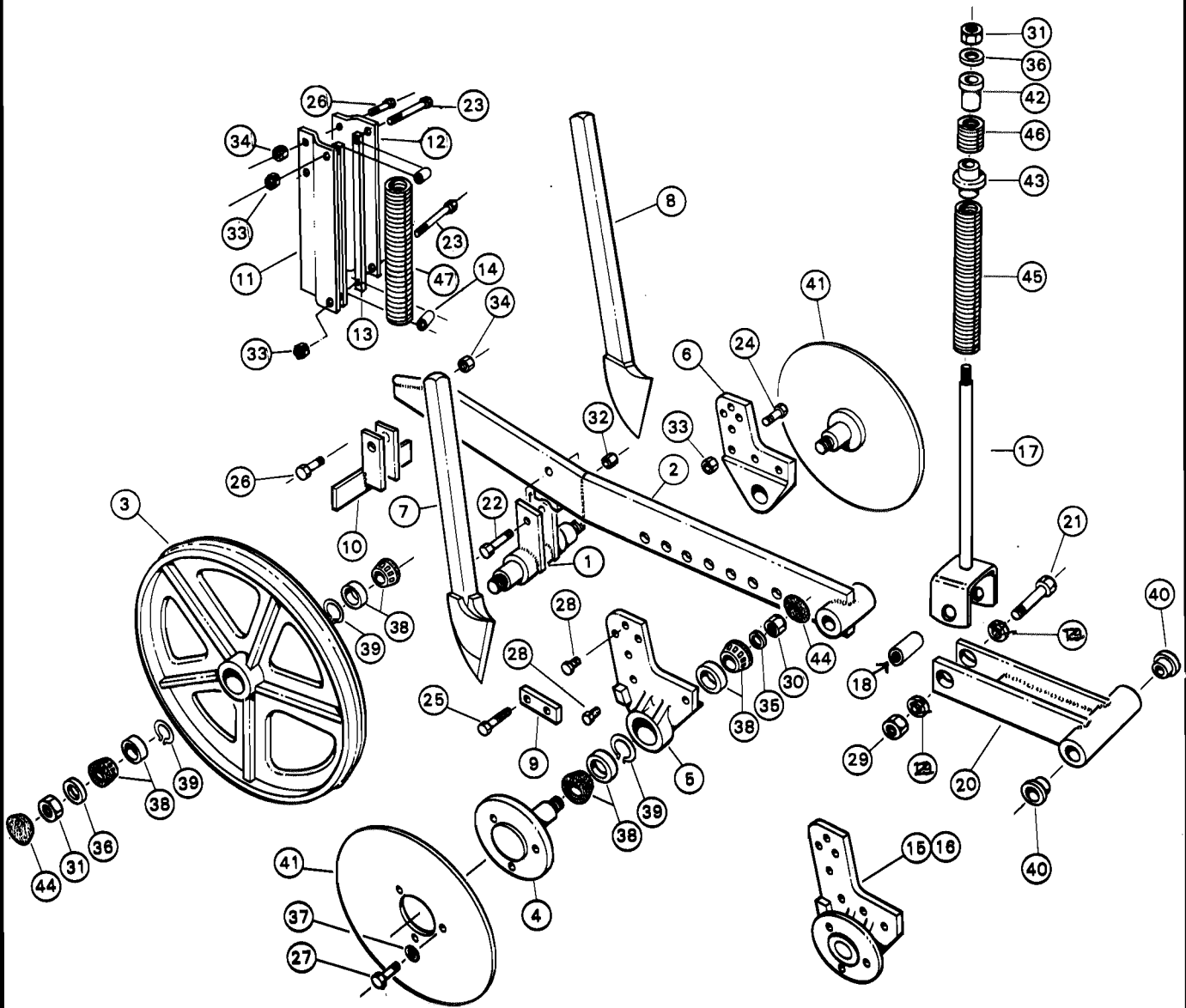

**DRAGARM SEEDING UNIT**

<b>ITEM</b>	<b>PART NO.</b>	<b>DESCRIPTION</b>	<b>QTY</b>
1	201-1000	Dragarm Axle Unit	9
2	<del>220</del> 202-1234	Dragarm Mounting Bar	9
3	203-1234	Press Wheel	18
4	204-1234	Disc Hub	18
5	205-1000	Disc Mounting Bracket - RH	9
6	206-1000	Disc Mounting Bracket - LH	9
7	207-1234	Seedtube Coulter - RH	9
8	208-1234	Seed Tube Coulter - LH	9
9	209-1234	Seed Tube Retaining Plate	18
10	210-1000	Press Wheel Scraper	9
11	211-1234	Dragarm Guide Plate - RH	9
12	212-1234	Dragarm Guide Plate - LH	9
13	213-1234	Guide Plate Bar	18
14	214-1234	Guide Plate Distance Piece	18
15	215-1000	Disc Bearing Replacement Unit - RH	9
16	216-1000	Disc Bearing Replacement Unit - LH	9
17	2.21 <del>217</del> -1234	Front Spring Arm	9
18	A149 <del>218-1234</del>	Front Pivot Sleeve 1/2" x 1 3/4" SPIROL PIN	9
19	<del>219-1234</del>	Front Pivot Bush	18
20	140-1234	Pivot Arm Unit	9
21	A103 A102	1" x 4 3/4" 3/4" x 4 1/2" UNC Bolt	9
22	A107	M16 x 55 Bolt	9
23	A110	M12 x 75 Bolt	18
24	A111	M12 x 55 Bolt	18
25	A113	M10 x 65 Bolt	36
26	A114	M10 x 50 Bolt	27
27	A120	3/8 x 5/8 UNF. Setscrew	54
28	A122	M10 x 20 Setscrew	36
29	A130	1" UNC Locknut	9
30	A132	3/4 UNF Locknut	18
31	A133	5/8 UNF Locknut	18
32	A137	M16 Locknut	9
33	A138	M12 Locknut	36
34	A139	M10 Locknut	27
35	A145	M20 x 32 H.D Washer	18
36	A146	M16 x 32 H.D. Washer	18
37	A148	M10 Shake Proof Washer	54
38	A157	1" Timken Taper Roller Bearing	72
39	A158	1" Timken Circlip	54
40	A159	Oilite Bush	24
41	A160	Seed Disc Coulter 16" Dia.	18
42	A180	Spring Retaining Bush	9
43	A181	Spring Locating Bush	9
44	A182	Dust Cap - Small	36
45	A186	Front Spring - Lower	9
46	A187	Front Spring - Upper	9
47	A189	Rear Spring - H.D.	9



## SEEDBOX &amp; DRIVE UNIT

ITEM	PART NO.	DESCRIPTION	QTY.
1	310-1000	Seed Box Mounting Bracket RH	1
2	312-1000	Chaindrive Guard Bracket	1
3	313-1000	Support Arm Pivot Bracket	1
4	314-1034	Drive Wheel Support Arm - Upper	1
5	315-1034	Drive Wheel Support Arm - Lower	1
6	316-1034	Drive Wheel	1
7	317-1034	Drive Wheel Axle	1
8	318-1034	Drive Wheel Spacer	1
9	319-1034	Pivot Bracket Bearing Washer	1
10	320-1000	Chain Guard Cover	1
12	322-1000	Chain Guard Lower	1
13	323-1234	9T Double Drive Sprocket	1
14	324-1000	10T Drive Sprocket Lower	1
15	325-1034	21T Drive Sprocket Upper	1
17	329-1234	Chain Connecting Link	2
18	331-1000	72L Drive Chain - Lower	1
19	332-1000	60L Drive Chain - Upper	1
20	A105	M20 x 100 Bolt	2
21	A111	M12 x 55 Bolt	2
22	A121	M10 x 60 Setscrew	1
23	A123	M8 x 16 Setscrew	8
24	A126	M6 x 10 Socket Head	36
25	A133	5/8 UNF Locknut	2
26	A134	M10 Wing Nut	3
27	A135	M20 Lock Nut	2
28	A138	M12 Lock Nut	2
29	A146	M16 x 32 Washer - HD	2
30	A156	1 3/8 Timken Taper Roller Bearing	6
31	A157	1" Timken Taper Roller Bearing	4
32	A162	Acrometer	1
33	A163	Acrometer Link Arm	1
34	A182	Dust Cap - Small	1
35	A183	Dust Cap - Large	1
36	A211	Seed Box Shell	1
37	A221	Seed Box Lid	1
38	A231	Collection Tray/Cover R.H.	1
39	A241	Collection Tray/Cover L.H.	1
40	A251	Seedcup Holder Unit	1
41	A261	Rotor Drive Shaft	1
42	A271	Distribution Shaft	1
43	A341	Small Seed Box	8
44	A310 <sup>S</sup>	Flexible Seed Tube 3T	18
45	A320 <sup>B</sup>	Seed Tube Joint	18
46	A330	Seed Cup Holder	18
47	A340	Large Seed Box	1
48	A350	Feed Rotor	18
49	A360	Callibration Handle	1
50	A370	Distribution - Main Unit	18
51	A380	Distribution - Sluicgate Unit	18
52	A390	Distribution - Plastic Cover	18
53	A400	Distribution - Nylon Shutter	18
54	A410	Callibration - Hand Adjustment Screw	1
55	A420	Callibration - Spring	1
56	A430	Callibration - Adjustment Nut	1
57	A440	Callibration - Screw Thread	1
58	A450	Callibration - Pointer Shaft	1
59	A460	Callibration - Pointer Locator	1
60	A470	Callibration - Pointer Handle	1
61	A480	Callibration - Graduated Box	1
62	A490	Seed Box - Pivot Casting	2
63	A500	Seed Box - Bearing Casting	2
64	A510	Channel Retaining Bracket	2
65	A520	Seedbox - Retaining Screw	2
66	A530	Nylon Clip	6
67	A325	SEED TUBE BELLOW	18