

Moore

4 METRE ALL TILL SEED BED DRILL

BRITISH PATENT Nos. 1,218,785 1,591,607 2,040,656.
U.S.A. PATENT Nos. 3,611,956 4,196,679. AUSTRALIA PATENT No. 518,030.
CANADA PATENT No. 1,082,530. NEW ZEALAND PATENT No. 192,436.
SOUTH AFRICA PATENT No. 79/6679. OTHER PATENTS PENDING.

Instruction Manual & Parts List.

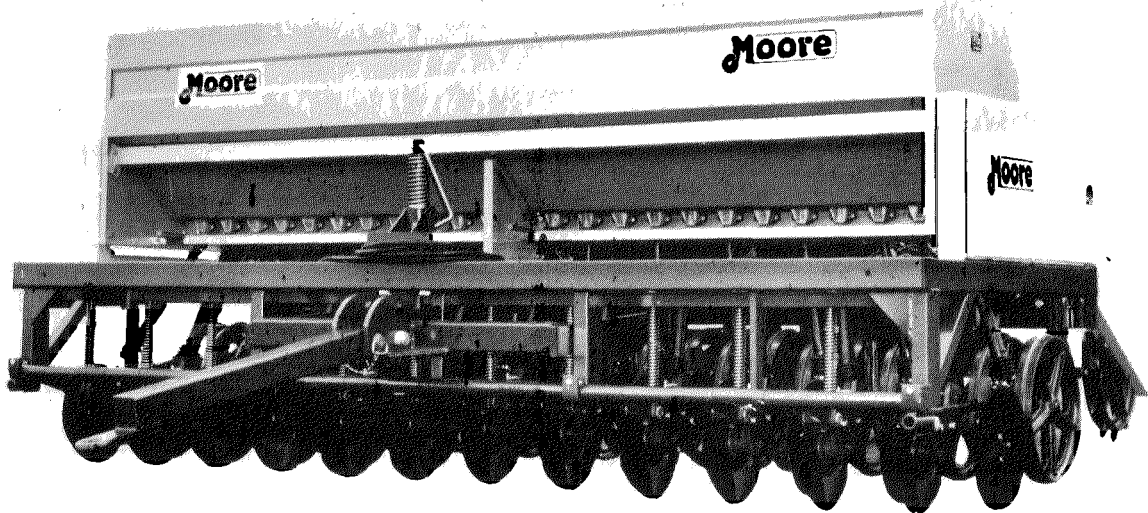

Moore Uni-drill Ltd.

NEWHILL HOUSE, 33 KIRK ROAD, BALLYMONEY BT53 6PP, CO. ANTRIM,
N. IRELAND. TELEPHONE: BALLYMONEY (02656) 64444 FAX NO. (02656) 65696.

April 1989

APPROXIMATE SEEDING RATES FOR MOORE ALL TILL SEED BED DRILL

4 M

CALIBRATION SCALE READING	SOWING RATES LBS./ACRE										
	ITALIAN RYEGRASS (COARSE)		GRASS SEEDS MIXTURE (FINE)		CEREALS, WHEAT, BARLEY OATS, RYE		LARGE SEEDS PEAS, SOYA BEANS		SMALL SEEDS TURNIPS, KALE RAPE, ALFAFA		
	21T	34T	21T	34T	21T	34T	21T	34T	21T	34T	
2										3	2
3										6	4
4										13	8
5										26	16
6											32
7			11	7							
8			16	10	30	20					
9			23	14	50	30					
10			32	20	70	45					
11			44	27	95	60					
12	12	7	56	35	120	75					
13	15	9	72	45	150	90	110	70			
14	18	11	90	56	180	110	145	90			
15	22	13			210	130	180	110			
16	26	16			250	155	220	135			
17	31	19			290	185	260	160			
18	36	22			335	225	310	190			
19	41	25			380	270	385	240			
20	48	30									
21	56	35									
22	64	40									

NOTE: This Seed Chart is not a guarantee of the correct amount of seed to be sown - use it only as a guide for the seed quantities required.

Correct seed rates can be obtained by actuating the Acrometer as follows:

AREA	NO. OF TEETH ON SEEDBOX SPROCKET	ACTUATIONS OF ACROMETER	TURNS OF HANDLE ON SEEDBOX
One tenth acre	21 tooth	100	43
	34 tooth	100	26
one twentieth hectare	21 tooth	125	53
	34 tooth	125	33

Weigh the seeds in the collection trays provided. The weight of the seed is equivalent to that used to sow one tenth of an acre.

By adjusting the Micrometer Control Screw, the rate can be varied and the desired seed rate obtained.

The 34 tooth sprocket should be used when sowing small seeds such as turnips, kale, rape etc., especially when mixed with slug pellets, also for larger seeds such as peas, beans, etc., where less power is required to turn the rotor.

FIGURE A: MINIMUM PENETRATION

*Uni-Drill with all the weight on the press wheel rollers-
Disc seed coulters not touching ground*

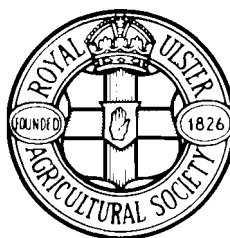
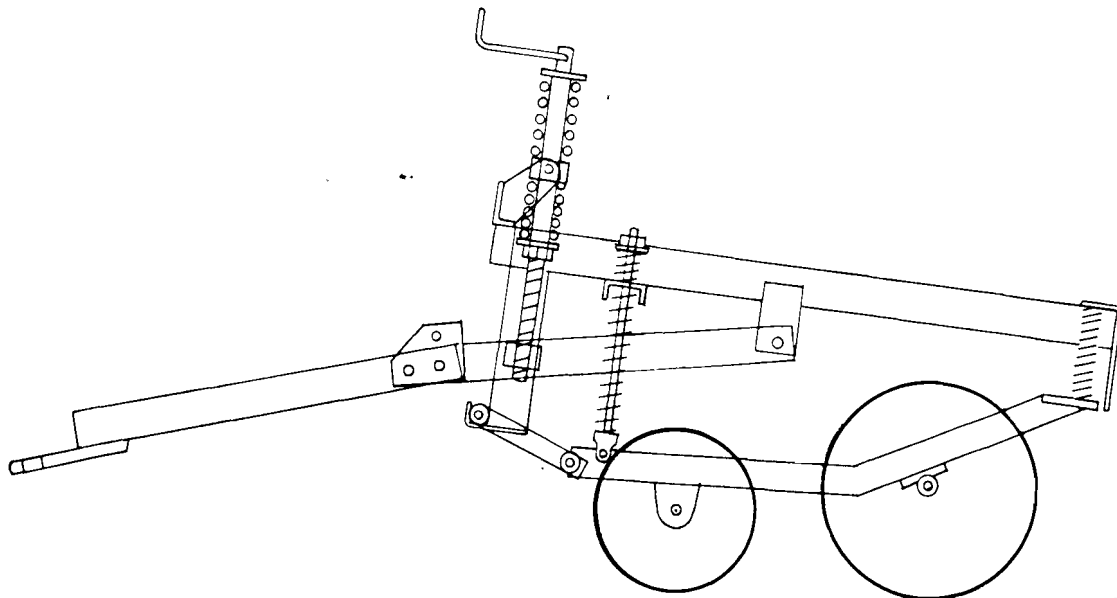

ALSO WINNER OF THE BURKE TROPHY FOR THE MACHINE OF
OUTSTANDING MERIT AT
THE ROYAL AGRICULTURAL SOCIETY OF ENGLAND SHOW 1976

FIGURE B: MAXIMUM PENETRATION

*Uni-Drill with all the weight on the disc seed coulters -
Press wheel rollers not touching ground*

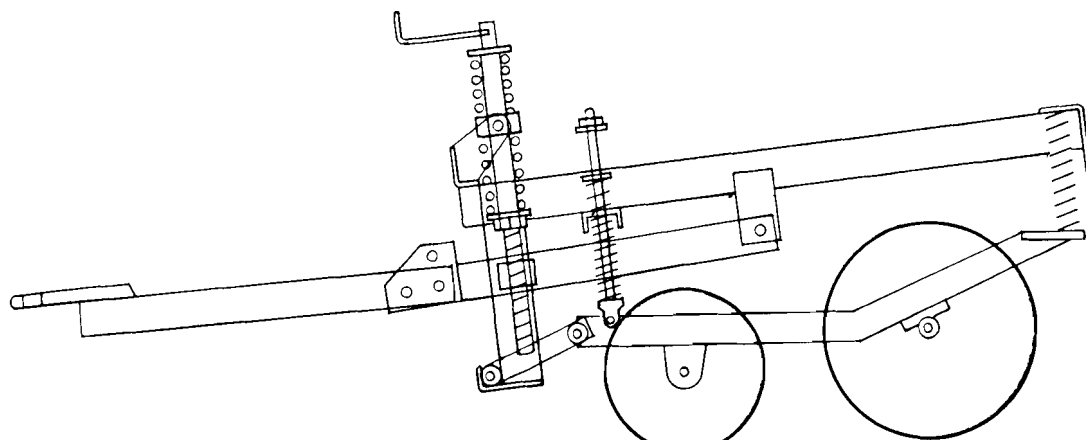

1. DESCRIPTION

The All-Till seedbed drills will sow most seeds into a variety of seedbeds. They can be used for conventional seedbeds with remarkable accuracy of depth of seed placement, also they can be used in minimum tillage, scratch tillage, direct drilling or no-till situations. The unique high inertia coulter system, with press wheel, maintains constant depth of seed placement under such a variety of conditions, including trashy and straw incorporated soils, at higher speeds than most drills can accommodate.

The All-Till seedbed drills consist of a row of independent dragarm seeding units which are spring mounted to the main frame. Each unit consists of 2 discs and 2 press wheel rollers - the discs are mounted each side of the dragarm at opposite angles. A seed tube coulter is mounted on the inside of each disc, in a position which enables the seed to be placed in a slit cut by the disc.

The press wheel rollers are mounted to the rear of the dragarms behind the discs, rolling directly over the slits.

2. SPECIFICATION

Sowing Width	13 ft. 1.5 ins.	4000 mm
Overall Width	13 ft.	3960 mm
Total Weight	5,870 lbs.	2,670 kgs.
No. of Coulters	24	24
Row Width	6.5 ins.	166 mm
Seedbox Capacity	54 cu. ft.	1500 litres

3. WORKING PRINCIPLE

When the drill is in the raised position, the weight of the machine is carried on the two transport wheels and the tractor drawbar. As the machine is lowered, the disc coulters and press wheels touch the ground, meet resistance from the soil, and begin to compress the springs attached to each end of the dragarm seeding units. The frame can be lowered until all the available weight of the machine is supported on the springs.

The penetration of the discs and hence the seed depth is controlled by the depth adjusting screw. This alters the relationship between the discs and the roller press wheels; weight can be transferred from the rollers to the discs or vice-versa (See Figs A and B page 1). As each dragarm is separately sprung both front and back, each unit is able to follow ground contours independently. As the drill is drawn forward, the inclined disc opens a slit and the seed tube coulter acts like a tine to prepare a tilth into which the seeds are placed. The roller press wheels then consolidate to ensure good seed/soil contact and moisture retention.

4. TRANSPORT

The drill is raised and lowered hydraulically and locking pins are provided for road transport.

Double acting hydraulic rams are fitted to the drill. Both hydraulic hoses should be connected to the spool valve on the tractor. Always keep the road wheels fully raised while the drill is in work, so as not to affect the depth control of the drill in undulating fields.

For transportation or moving the drill from field to field always ensure that the road transport pins are fitted. Also, the seed distribution units can be closed by pushing the pointer handle to the top of the graduation scale (See Fig. 2). It can be locked in this position by dropping the locator into the transport location hole.

5. DEPTH CONTROL

Set the drawbar with the ring hitch underneath (as shown in Fig. A) when drilling cultivated land and soft seedbeds.

Set the drawbar with the ring hitch on top (as shown in Fig. B) when direct drilling or drilling very firm seedbeds.

A fine adjustment is achieved by turning the depth adjustment screw to raise or lower the discs to the required depth in different field conditions and seed requirements; turning the screw clockwise increases depth, while turning the screw anti-clockwise reduces the depth. Care must be taken with this setting to achieve correct seed depth and effective pressing with the rear press wheels.

Sometimes in dry loose cloddy conditions it is better to set the drawbar with ring hitch on top (Fig. B.). This will allow more weight to be put on the press wheels, letting them turn more positively, whilst still achieving adequate disc penetration.

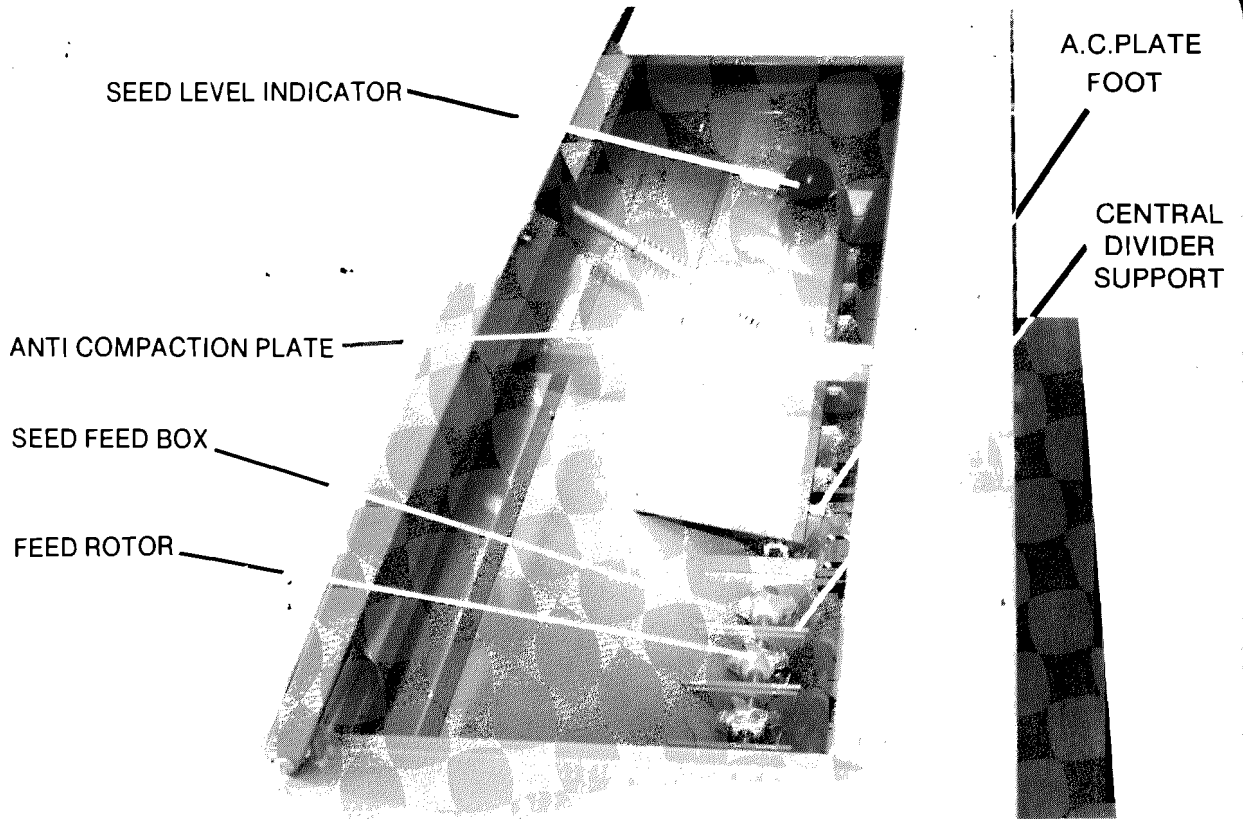

FIGURE 3. SEEDBOX

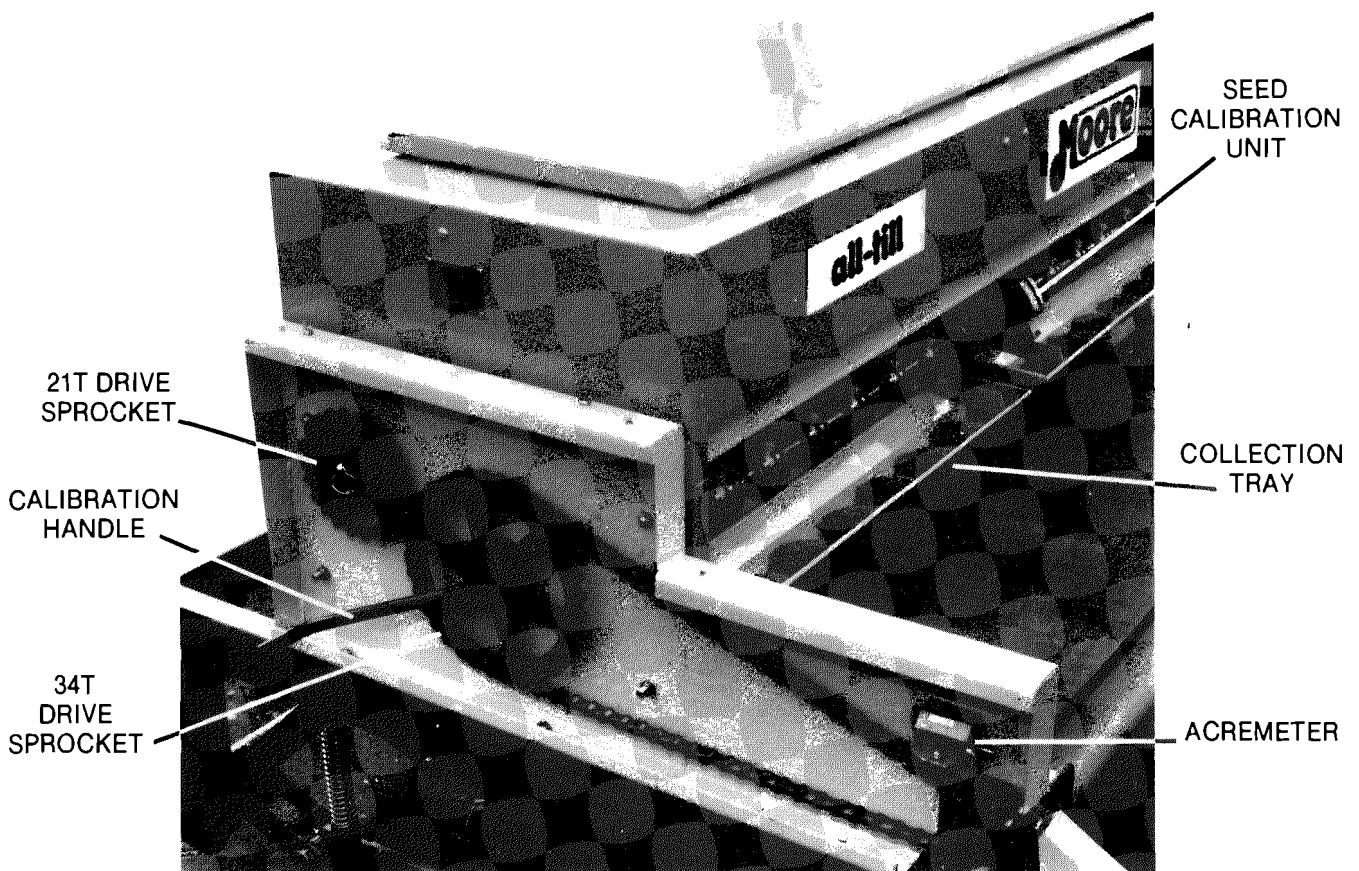

FIGURE 4. CALIBRATION

6. SEEDBOX (See Fig. 2 and 3)

Each seed distribution unit of the Moore All-Till seedbed drills is supplied with seed from the hopper by means of a seed feed box. The variable opening of the distribution unit regulates the seed rate. At the lowest part of the feeding box, a plastic feed rotor, operated by the stalker drive wheel, supplies the distribution unit with seed at a high degree of uniformity. Made of flexible plastic (Lucolen) the feed rotor is adapted to, and fits the shape of all kinds of seed: large or small, heavy or light, round or long. Anti-compaction plates can be fitted over the seed feed boxes to give less damage to the larger, more easily damaged seeds such as soya beans or peas.

IMPORTANT: The anti-compaction plates must be fitted correctly. Make sure the feet on the plate rest on top of the central divider supports. If the anti-compaction plates are fitted the wrong way round, the feet on the plates will not be supported by the central dividers.

A micrometer hand control screw is used to adjust the openings of the seed distribution units for precise seed rate settings.

7. CALIBRATION (See Fig. 4.)

The seed charts are not a guarantee of the correct amount of seed to be sown, use them only as a guide to the seed quantities required. Compilation of a seed rate chart is not possible due to variations in seed types and seed mixtures. Also the type and quantity of seed dressings used.

TO CHECK THE SEED RATE (STATIC CALIBRATION)

- A Set the calibration pointer to the reading as given in the Seeding Tables.
- B Open the covers protecting the distribution units and hinge them down to form collection trays for the seeds.
- C Release the spring loaded locating pins at each end of the seed cup holder unit and slide it forwards so that the seed collection trays are underneath the outlets of the seed distribution units.
- D Support the stalker drive wheel so that it clears the ground, and then ensure that the handle is turned so that the stalker drive wheel turns in the normal direction of travel.
- E Partially fill the seedbox and actuate the acremeter 100 times, 43 turns of the handle when attached to the 21 tooth seedbox sprocket. 26 turns of the handle when attached to the 34 tooth seedbox sprocket.
- F Remove the collection trays and weigh the seed: this will represent the seed rate for one-tenth of an acre. Multiply by 10 to obtain the seed rate per acre.
- G By adjusting the micrometer screw the rate can be varied and the desired seed rate obtained.

TO CHECK THE SEED RATE (DYNAMIC CALIBRATION)

With some seedbeds, especially those which are very clody but firm underneath, seed will tend to "bounce out", over and above the rate already calibrated whilst static.

Set up the drill as for the static calibration with the calibration trays set to catch the seed (C above). Drive the drill along the field at normal drilling speed. An assistant accompanies the drill on foot and stops the driver when the acremeter indicates that 0.10 of an acre has been covered. Once the tray sample has been weighed this will give a very accurate calibration in such conditions.

NOTE

By using the 34 tooth seedbox drive sprocket, the rotor drive shaft is turned slower and thus a larger opening of the seed distribution units is necessary to get the required seed rate per acre. This is useful when sowing small seeds such as turnips, kale, rape, etc., especially when mixed with slug pellets and also for large seeds such as peas, beans, etc., where less power is required to turn the rotors.

8. SEEDING AT DIFFERENT ROW WIDTHS

It is possible to sow seeds at row widths of 6 ½ ins. (16.5 cms), 13 ins. (33 cms), 19 ½ ins. (49.5 cms), and 26 ins. (66 cms).

Blank off the seeding units not required by turning the nylon blank off shutters to close the openings of the seed distribution units, as shown in Fig. 2.

9. EMPTYING SEEDBOX (See Fig. 4)

To empty Seedbox:-

- A Remove as much seed as possible using a hand shovel or scoop.
- B Place the seed collection trays underneath the outlets of the seed distribution units.
- C Fully open the seed distribution units.
- D Turn the seed rotors and remove as much seed as possible into the collection trays.

If no airline or vacuum is available to assist in the cleaning out of the seedbox, paper tissues can be used.

- E Wrap up a large paper tissue and place it between the rotor and the seed feed box.
- F Turn the rotor so that it will take the tissue around the bottom of the seedbox wiping it clean.

10. ACREMETER

The acremeter is actuated by a linkarm attached to the end of the double drive sprocket. The adjustable arm on the end of the meter should be positioned so that the linkarm is free when the end of the crank is at the top of its stroke.

The acremeter is calibrated so that it takes 1000 actuations to read 1 acre, therefore, only the first 2 digits read the acres and the last 2 digits the decimal fraction of an acre.

The acremeter can be set to zero by turning the ribbed knob on the end of the meter.

ACCURACY OF ACREMETER

The torque taken to drive the rotor shaft can cause the drive wheel to slip or drag in dry loose, crumbly or knobby soils. Also in wet conditions soil can build up on the drive wheel giving it a larger circumference, thus giving inaccurate acremeter readings.

To check the % error, measure the drive circumference of the drive wheel, using a tape-measure in the field. Measure the distance between 13 cog marks (i.e. 12 gaps or spaces) when the drill is being used at your normal drilling speed.

Use the following table to make corrections for calibrations and acreages.

CIRCUMFERENCE OF DRIVE WHEEL	% ERROR	No. Of Turns Of Handle On Seedbox Sprocket To Give One Tenth Acre		Reading of Acre-Meter To Give	
		21 TOOTH	34 TOOTH	10 ACRES	50 ACRES
66.5 "	-5%	45	27.5	10.5	52.5
70 "	CORRECT	43	26.0	10	50
73.5 "	5	41	24.5	9.5	47.5
77 "	10	39	23.0	9.0	45
80.5 "	15	37	21.5	8.5	42.5

11. MAINTENANCE

A NUTS AND BOLTS

All nuts and bolts should be checked regularly. When working in stony or trashy conditions it will be necessary to check all nuts and bolts daily, particularly the seed tube coulters and disc bolts.

B BEARINGS

Disc and press wheel bearings should be checked daily for correct adjustment.

1" Dia. Timken Duo Seal Taper Roller Bearings are fitted to the press wheels and disc hubs on the drill. Remove the dust cover and use a socket on the lock nut to tighten up the two taper roller bearings so that they can just turn freely. When the bearings are slack the rubber seals will wear thus allowing in dust, ending up with a dry bearing. The bearings are packed with Shell Alvania Grease.

IMPORTANT: REGULAR CHECKING OF THE BEARINGS WILL ENSURE TROUBLE FREE USE.

C SEED TUBE COULTER ADJUSTMENT

Check the position of the seed tube coulters in relation to the disc coulters daily.

For most seeding conditions and as a general rule the tip F of the seed tube coulters should be set so that it is approximately $\frac{1}{2}$ " above the outer edge of the disc. The leading edge of the seed coulters should be set parallel to the disc and just touching it. This can be achieved by means of the retaining bolts A and B and the adjusting screws C and D. If the tip, F, of the seed coulters is out from the disc, this can be corrected by tightening bolt A (front bolt) more than bolt B, while the top, G, of the seed coulters can be brought in towards the disc by tightening Bolt B (rear bolt) more than Bolt A.

Some discs, may be slightly distorted, but when in work the side force of the soil on the disc will keep it in contact with the seed coulters. A certain amount of bedding in and wear takes place between the disc and the seed coulters and it may become necessary to adjust screws C and D to position the seed coulters close to the disc.

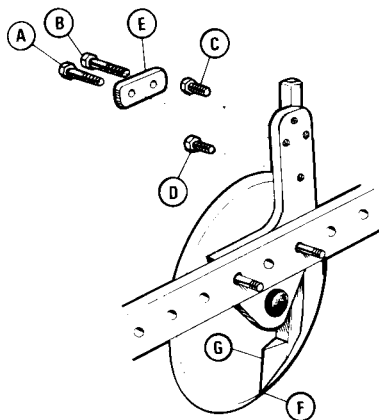

To obtain better depth control for small seeds e.g. oil seed, rape, turnips etc. in loose or cultivated soil it may be necessary to lower the tip of the seed tube coulters almost to the edge of the disc.

D DRAGARM FRONT PIVOT GREASE NIPPLE (See Fig. 1)

Apply grease to the front pivot nipple every 100 acres. It is important that this pivot nipple is greased at the end of each sowing season, or after the drill has been working and may not be used for a period of time. This prevents the pivot bolt from rusting and seizing in the pivot joint.

E SEED DISTRIBUTION AND CALIBRATION UNITS (See Fig. 2)

The calibration of the drill is very accurate; but sometimes, due to wear and tear, the sluice gates can become maladjusted. This will not be noticed when sowing large seeds such as peas or cereals. With low rates of small seeds such as oilseed rape this can show up, especially when calibrating, where large or small heaps of seeds are viewed in the collection trays.

The sluice gate units must be all checked to ensure that they are opening evenly (See fig. 2)

- 1 Remove the plastic covers and the nylon blank-off shutters.
- 2 Use the shank of a $\frac{1}{8}$ " drill bit, or a 3mm welding rod as a gauge.
- 3 Place the gauge on top of the control shaft and into the opening of the distribution unit.
- 4 Turn the micrometer hand adjustment screw until the sluice gate unit just closes on the gauge.
- 5 Using the gauge check that the rest of the sluice gates are opening by the same amount.
- 6 If some of the sluice gates are found to be too loose (large) or too tight (small), then adjust them as follows:-
 - (a) slacken the two grub screws securing the sluice gate to the control shaft.
 - (b) turn the sluice gate around on the control shaft and push it sideways to expose the groove cut by each grub screw point.
 - (c) gently file these grooves smooth to the profile of the control shaft; but do not make a "flat" on the shaft.
 - (d) replace the sluice gate and close it on the gauge and tighten the grub screws.
- 7 A final check can be made on the seed openings when oilseed rape is calibrated, if

adjusted correctly the heaps of seed in the trays should all look an even size.

- 8 If on the initial check only one or two of the sluice gates appear to be maladjusted. Then set the gauge up in the correctly adjusted sluice gates and adjust the other sluice gates as above.
- 9 Check the calibration pointer handle and make sure it is tight on the control shaft. If not, tighten up the grub screw on the bottom of the handle.

F TYRE PRESSURES

Standard tyres	10.5 X 15	35 Lbs / Sq. In.
Oversize tyres	31 X 15.5	25 Lbs / Sq. In.

12. OPERATION OF ALL TILL SEEDBED DRILLS

A. PREPARATION AND CALIBRATION

Attach the drill to the tractor and raise the drill to its maximum height, remove the road transport pins. Calibrate the seeding mechanism for seeds to be sown as in section 7.

B. RUNNING IN

If the drill is new and is to be used in cultivated soil, it is better to 'run-in' the drill in hard ground, such as a grass field. It is easier to work off the paint and rough edges from the seed tube and disc coulters when working in firm ground where there is more friction to turn the discs. This only requires a few runs across a field without seed. The depth control of the All-Till seedbed drill can be tried out by turning the depth control screw up or down to increase or decrease the depth of penetration. Check that all the discs turn relatively freely; it may be necessary to slacken off seed tubes that are rubbing tight against the discs.

C FIELD OPERATION

Do not turn sharp corners with the All-Till seedbed drills, especially in direct drilling operations as this will give wrong disc-to-soil side thrust. When this happens the disc is parted from the seed coulter and trash can then enter between them resulting in blockage to the seed flow. It is better to lift the machine out of and into work when turning corners.

D WORK RATE

As there is no disc bounce, due to the high inertia coulter system with press wheels, relatively high ground speeds can be tolerated giving high work rates. The operating speed and the quality of work which results is controlled by field conditions but wherever possible a steady speed should be maintained. As field conditions vary, it may be necessary to adjust the coulter settings to maintain seed depth and cover.

E SEEDBED PREPARATION

It is not necessary to prepare a fine seedbed as for other drills. The All-Till seedbed drill prepares its own mini seedbed by using an angled disc and seed tube coulter tine. In most fields it is only necessary to plough and perhaps level and roll. If the soils are loose, puffy, soft or have loose stones on the surface, it will generally be advantageous to roll the field first. This will reduce blockages and help maintain even depth control.

Where a fine seedbed has been prepared and it gets wet, then the soil acts as a sponge and absorbs a lot of water, making it almost impossible for the drill or any other implement to work in it. Therefore it is better to consolidate loose seedbeds so that they will not absorb so much water. The drill will work on most firm consolidated seedbeds provided the drill is being used at speed. At a speed of over 6 M.P.H. the centrifugal force on the discs and rollers tends to fling the sticky soil from them; just like driving a tractor along a road, where the dirt on the tyres is thrown off when it reaches a certain speed.

F DRILLING IN CONVENTIONAL SEEDBED

When working in cultivated soil, most of the drill weight is carried on the press wheel rollers and tractor drawbar. Seed depth can be obtained by adjusting the depth control screw in the usual manner. The soil is usually tracted to the depth required by the disc seeding units and consolidated by the press wheel rollers - this gives ideal conditions for seed germination.

It is recommended that the centre of the field should be drilled first and the headlands last. If the

headlands are planted first, then the tractor and drill will travel and turn on planted ground, thus disturbing, compacting and moving seeds that have been placed at a constant depth. Check seeding depth in the field and on headlands, remember the headlands tend to be more consolidated than the remainder of the field.

On rougher type of seedbeds the drill itself tends to be self levelling. The seed tube and disc coulter units tend to move the soil from humps to hollows. **IT IS NOT NECESSARY TO HARROW AFTER SOWING.** Harrowing will move seeds either shallower or deeper thus giving uneven germination. Remember seeds that are planted two to three inches deep take about two weeks longer to germinate and appear as weak plants, that are under stress and are susceptible to disease.

If rolling behind the drill on lighter soils is thought to be beneficial, remember that the seed has been accurately placed at the ideal depth for early and even emergence. Rolling will tend to flatten the ridge of soil between each press wheel mark and will in fact add to the soil cover over the seed thus slowing emergence and probably reducing vigour. This extra soil cover over the seed must be allowed for, when deciding drilling depth when starting the field.

G DRILLING IN WET CONDITIONS

The All-Till seedbed drills are now fitted with adjustable scrapers for the press wheels. Wet soil will usually build up to about one inch on any wheel. Adjust the scrapers so as to knock off the excess soil that would build up over the normal amount of soil that sticks to the press wheels. Leave a gap of 1 in - 1 ¼ in. between the scraper and the press wheel. Never reverse the drill with the seed tube coulters in the ground as this would block the seed outlets with soil. Where there are very wet pockets of soil in some fields, the road wheels can be used to slightly raise the drill out of the ground thus assisting the drill through the difficult areas. Be careful not to raise the drill too high; always keep the stalker wheel in contact with the ground.

H DRILLING INTO STRAW INCORPORATED SOIL AND TRASHY CONDITIONS

In heavy trash conditions it may be necessary to raise the tip of the seed tube coulters, so that the disc will cut through the trash before the coulter opens the slit. In heavy maize trash, especially in the direct drill or no-till situation, it may be necessary to raise the tip of the seed tube coulter 1" to 1 ½" above the edge of the disc.

The discs cut through the trash very positively. The weight of the press wheels keep the discs anchored and do not allow the discs to ride out of the soil, even when there is a lot of trash present. Bulldozing normally occurs when a disc meets trash, tries to ride up over the trash, then pushes it in front of the disc, thus causing bulldozing and blockages. If this happens it is usually due to the soil underneath being too loose. The drill will cut cleanly through, given that it has something to "bite on". Consolidating the field with either rollers or a land packer, sufficient to allow the drill's discs to turn, will usually cure the problem.

The trash itself, on decaying, produces acids, toxins, etc., which tend to damage or kill the germinating seed. If the trash is mixed with the soil and consolidated tightly to give good straw/soil contact then the soil will absorb the toxins as they are formed, before they can harm the germinating seedlings. The press wheels on the All-Till seedbed drill consolidate the trash, soil and seed in exactly the right manner to give very healthy plant stands even in the heaviest incorporated residues.

If straw is incorporated into the soil to leave a loose fluffy seedbed then it is better to consolidate this first using either a roller, crumbler bar, land packer, etc. before drilling.

I MINIMUM TILLAGE AND DIRECT DRILLING

In certain soils, especially if they contain stone or brash, it is recommended that the top 1" or 2" should be cultivated or scratch tilled. This will encourage the germination of volunteer cereals and weed seeds. It will also help to level out the tramline and wheeled tracks. Also if stones are left undisturbed in the top layer, they become embedded and the disc will ride from stone to stone without getting good penetration.

In soft field conditions it is essential to set the discs deep enough to cut through all the matt or surface trash. Seed will germinate and grow better when in contact with the soil. In wet, soft conditions the disc may be set to penetrate deeper than required. As the drill moves forward the seed is trapped by the sides of the slit and do not necessarily fall to the bottom of the slit.

J DIRECT DRILLING GRASS PASTURES

Four methods are suggested for direct reseeding grass into grass pastures.

- A If the pasture has been badly poached or there are bare patches due to frost kill etc. over the winter, about 20 lbs/acre of a vigorous growing type of grass (eg I.R.G.) should be drilled just before growth starts (March/April).
- B Where a first or second cut of silage is being taken, cut low to the ground and direct drill the new grass seeds mixture the next day. There should be enough moisture retained in the soil to germinate the seed and get it growing before the cut sward can fully recover.
- C Graze the pasture as bare as possible, then spray with Gramoxone (1 pint/acre) and direct drill the new seeds mixture. The Gramoxone used at a low rate will not completely kill the old grass sward but should retard its growth sufficiently to get the new seeds established.
- D Where the old pasture is very weedy and a complete reseed is required, spray with Roundup to get a total kill of vegetation. Leave the field for the recommended period and direct drill with the new seeds mixture. To get a better grass cover, cross drilling at an angle is recommended, especially with the wider row spacing in Uni-Drills.

Check the reseeds for leather jacket, slug or frit fly damage and treat accordingly.

Grass seed mixtures should be treated with a Frit Fly dressing especially if they are to be sown after the 1st August.

K OTHER SUGGESTIONS

(i) LARGE SEED

With certain types of peas, beans, etc. the large seeds tend to catch between the rotor and bottom of the seed feed box, thus splitting and damaging the seeds. Some users keep and use a second set of rotors from which about $\frac{1}{4}$ " has been cut off the end of the plastic vanes. With the shorter rotors, the large seeds will not jam between the rotor vane tips and the bottom of the seed feed box. Less power will be required to turn the drive wheel and less damage to the seeds will occur. But before fitting a set of shortened rotors, the anti-compaction plates should be tried as this often solves the problem by taking the downward force exerted by a full seedbox, away from the feed rotors.

(ii) FEED ROTORS

With small seeds such as oilseed rape, especially if they are covered with seed dressings, it is important to check the flow of seeds from the distribution units. The dressings, especially when damp, tend to build up around the openings like cement, reducing the size of the opening and thus the seed rate. A small nail or a length of wire can be used to clear the build up of the dressings.

(iii) PRE EMERGENCE MARKING

Once the operator is used to the hydraulic system operating the transport wheels. The wheels can be adjusted to just make a mark on the soil behind the drill. This can be easily followed for pre-emergent chemical applications.

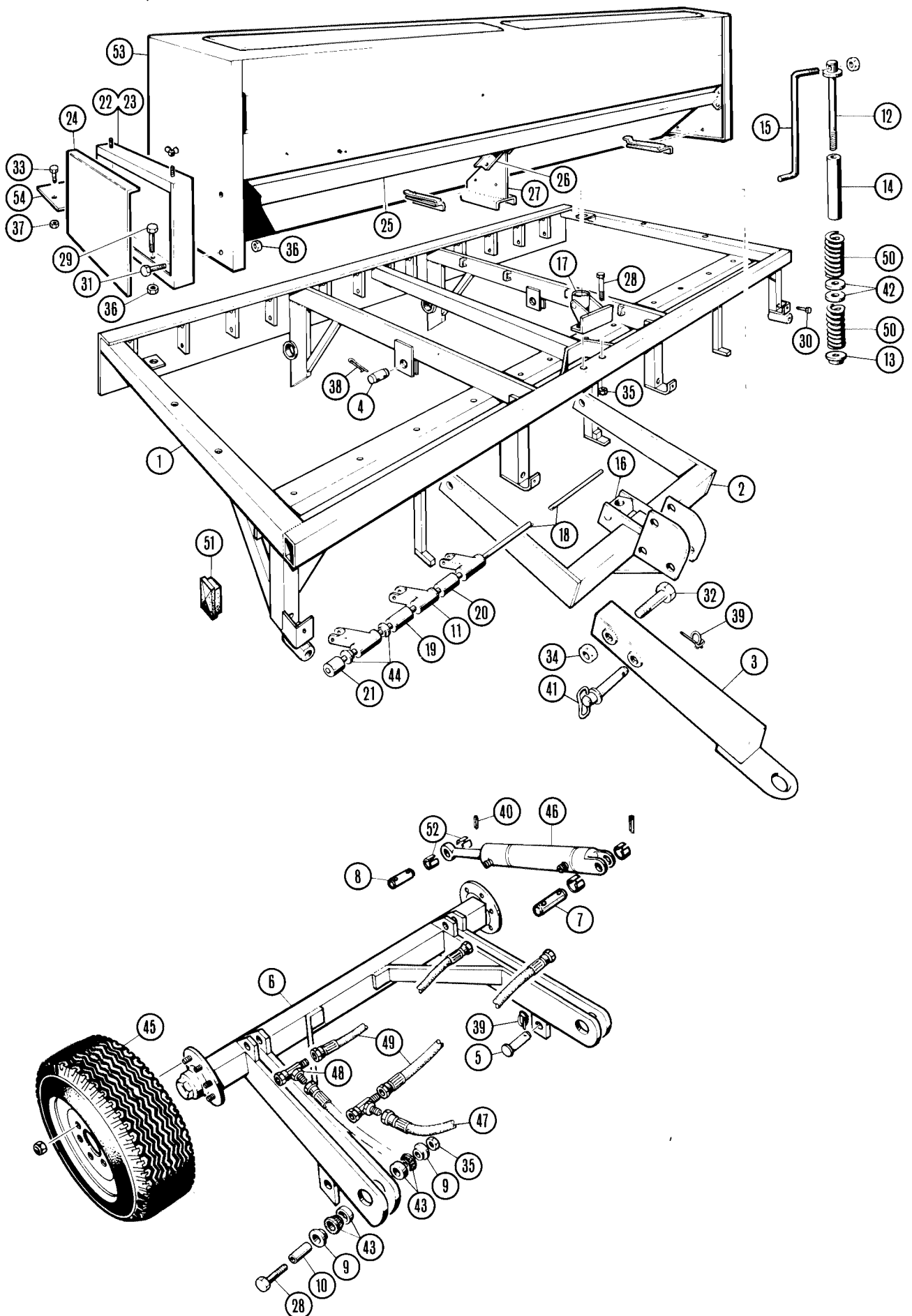

4M MAIN FRAME & DRAWBAR UNIT

ITEM	PART NO.	DESCRIPTION	QTY.
1	110-0004	Main Frame	1
2	120-0004	Drawbar Assembly	1
3	121-1234	Drawbar Towing Arm	1
4	122-1234	Drawbar Connecting Pin	2
5	125-1234	Transport Pin	2
6	126-0004	Axle Mounting Unit	1
7	128-1234	Ram - Top Pin	2
8	129-1234	Ram - Bottom Pin	2
9	130-1234	Pivot Collar - Axle Unit	4
10	131-1234	Pivot Bush - Axle Unit	2
11	132-1034	Pivoting Arm Unit	12
12	134-1234	Depth Control Screw	1
13	135-1234	Depth Control Screw - Nut	1
14	136-1234	Depth Control Screw - Tube	1
15	137-1234	Depth Control Screw - Handle	1
16	138-1234	Depth Control Screw - Trunnion	1
17	139-1234	Depth Control Screw Holder	1
18	141-0004	Front Pivot Bar	1
19	142-0234	Spacer Bush - Inner	9
20	143-0234	Spacer Bush - Inner Bushed	2
21	144-0004	Spacer Bush - End	2
22	350-0004	Seedbox Mounting Bracket - R.H.	1
23	351-0004	Seedbox Mounting Bracket - L.H.	1
24	360-0004	Chain Guard Cover - Large	2
25	370-0004	Seedbox Support	2
26	371-0004	Seedbox Centre Support - Top	1
27	372-0004	Seedbox Centre Support - Bottom	1
28	A101	1" x 6" UNC Bolt	4
29	A108	M12 x 120	4
30	A110	M12 x 75 Bolt	4
31	A112	M12 x 45 Bolt	12
32	A117	1 1/4" x 7 1/2" UNC Bolt	4
33	A121	M10 x 40 Set Screw	1
34	A129	1 1/4" UNC Nyloc Nut	1
35	A130	1" LINC Locknut	4
36	A138	M12 Locknut	10
37	A139	M10 Locknut	4
38	A150	M6 x 50 Split Pin	4
39	A152	Lynch Pin	4
40	A153	M8 x 40 Spirol Pin	8
41	A154	1 1/4" x 8" Drawbar Pin	1
42	A155	2" Timken Thrust Bearing	2
43	A156	1 3/8" Timken Taper Roller Bearing	4
44	A159	Oilite Bush	30
45	A165	Road Wheel - 15.5 x 15 x 6 Ply	2
46	A169	2 1/2" Dia. Hydraulic Cylinder	2
47	A171	Hydraulic Hose - Ram Tractor	2
48	A173	3/8" B.S.P. Tee M.M.F.	2
49	A179	Hydraulic Hose - Ram Ram	2
50	A185	Depth Control Spring	2
51	A198	100 x 50 Plastic Cap	4
52	A199	1 1/8" x 1" Hardened Bush	6
53	A207	Seed Box Complete	1
54	A297	Rear Platform	1

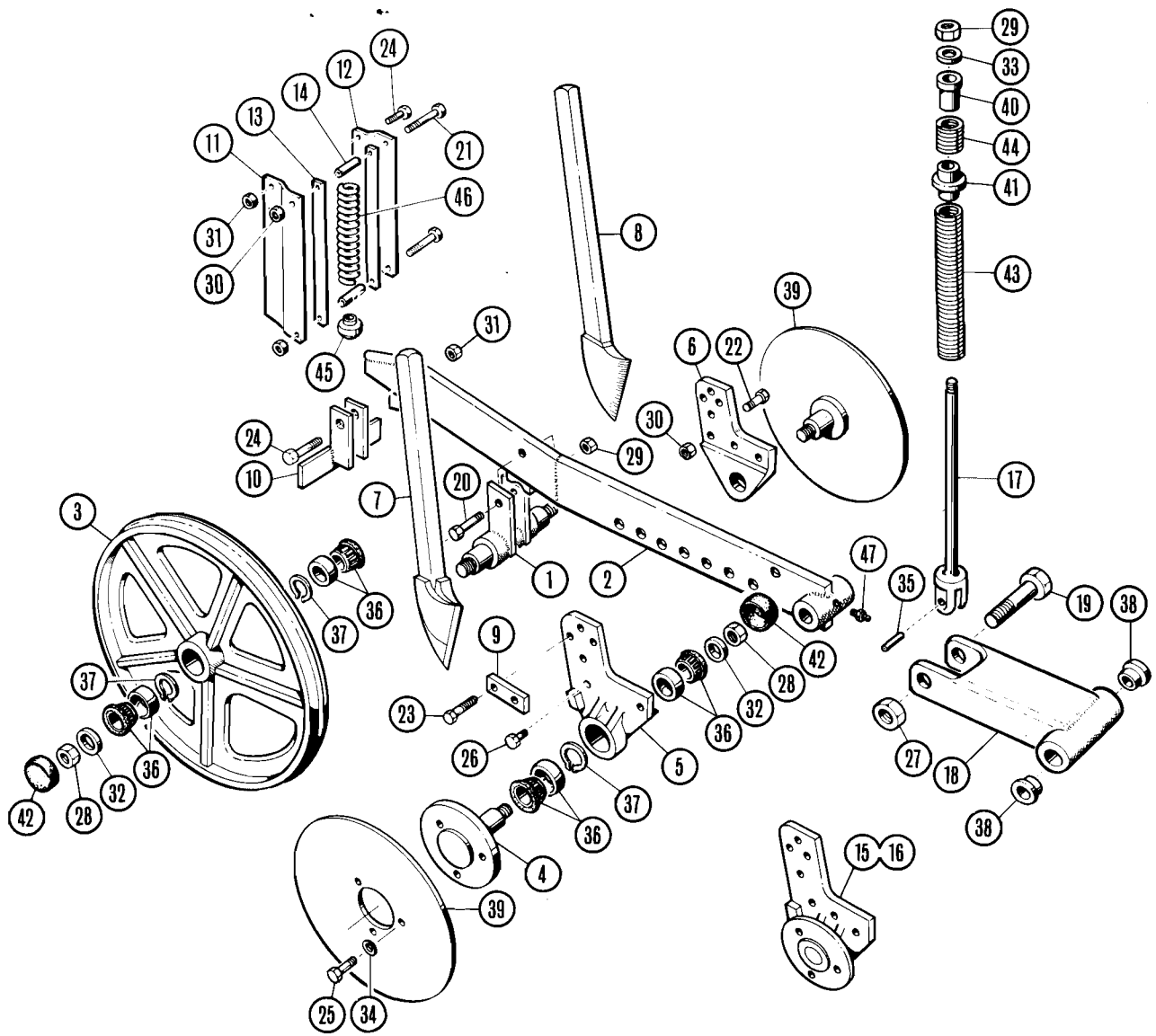

4M DRAGARM SEEDING UNIT

ITEM	PART NO.	DESCRIPTION	QTY.
1	201-0234	Dragarm Axle Unit	12
2	220-1034	Dragarm Mounting Bar	12
3	203-1034	Press Wheel	24
4	204-1234	Disc Hub	24
5	205-0034	Disc Mounting Bracket - R.H.	12
6	206-0034	Disc Mounting Bracket - L.H.	12
7	207-1234	Seed Tube Coulter - R.H.	12
8	208-1234	Seed Tube Coulter - L.H.	12
9	209-1234	Seed Tube Retaining Plate	24
10	210-0034	Press Wheel Scraper	12
11	211-1234	Dragarm Guide Plate - R.H.	12
12	212-1234	Dragarm Guide Plate - L.H.	12
13	213-1234	Guide Plate Bar	24
14	214-1234	Guide Plate Distance Piece	24
15	215-0234	Disc Bearing Replacement Unit - R.H.	12
16	216-0234	Disc Bearing Replacement Unit - L.H.	12
17	221-1234	Front Spring Arm	12
18	132-1034	Pivot Arm Unit	12
19	A103	1" x 4 3/4" UNC Bolt	12
20	A107	M 16 x 55 Bolt	12
21	A110	M 12 x 75 Bolt	24
22	A111	M 12 x 55 Bolt	24
23	A113	M 10 x 65 Bolt	48
24	A114	M 10 x 50 Bolt	36
25	A120	3/8" x 5/8" UNF Setscrew	72
26	A122	M 10 x 20 Setscrew	48
27	A130	1" UNC Locknut	12
28	A132	3/4" UNF. Locknut	48
29	A137	M 16 Locknut	24
30	A138	M 12 Locknut	72
31	A139	M 10 Locknut	36
32	A145	M 20 x 35 H.D. Washer	36
33	A146	M16 x 32 H.D. Washer	12
34	A148	M 10 Shake Proof Washer	72
35	A149	1/2" x 1 3/4" Spirol Pin	12
36	A157	1" Timken Taper Roller Bearing	96
37	A158	1" Timken Circlip	72
38	A159	Oilite Bush	30
39	A160	Seed Disc Coulter 16" Dia.	24
40	A180	Spring Retaining Bush	12
41	A181	Spring Locating Bush	12
42	A182	Dust Cap - Small	48
43	A186	Front Spring - Lower	12
44	A187	Front Spring - Upper	12
45	A188	Rear Spring Bush	12
46	A189	Rear Spring - H.D.	12
47	A190	Grease Nipple	12

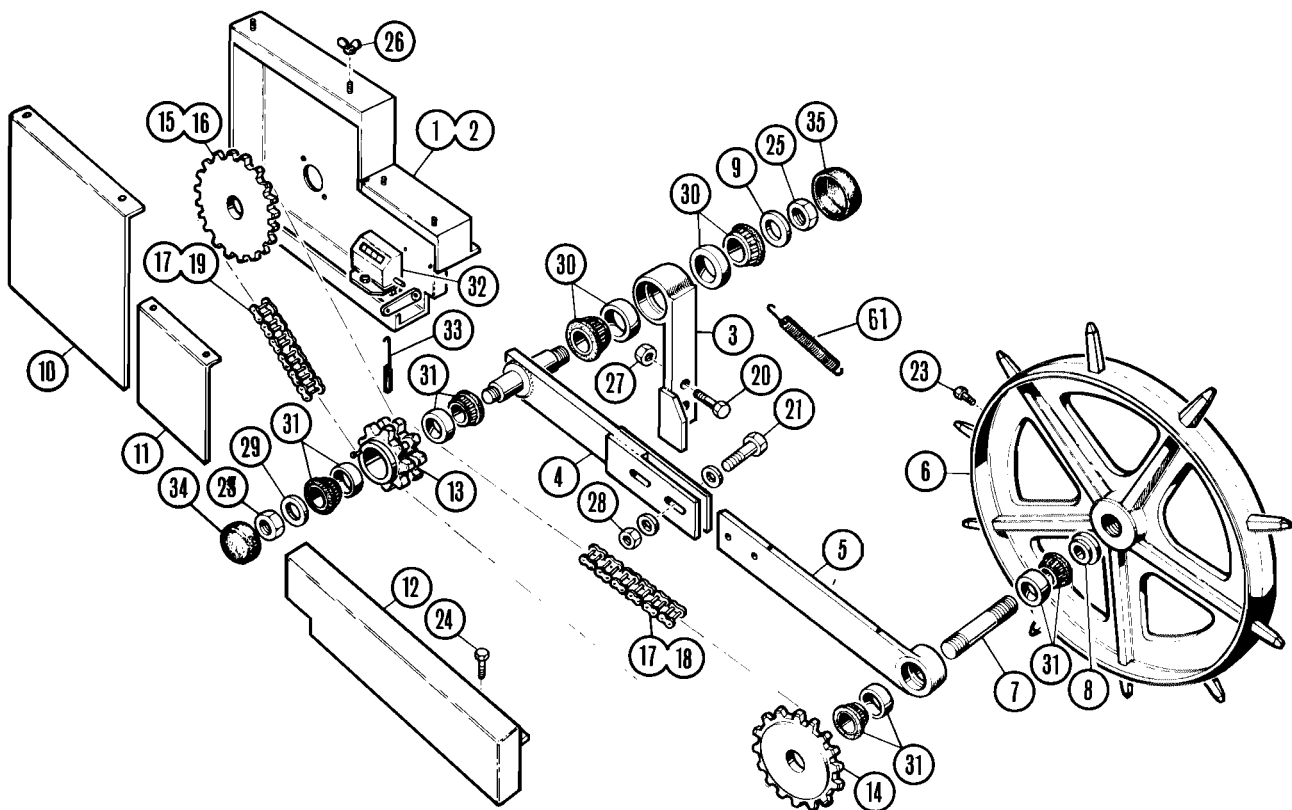
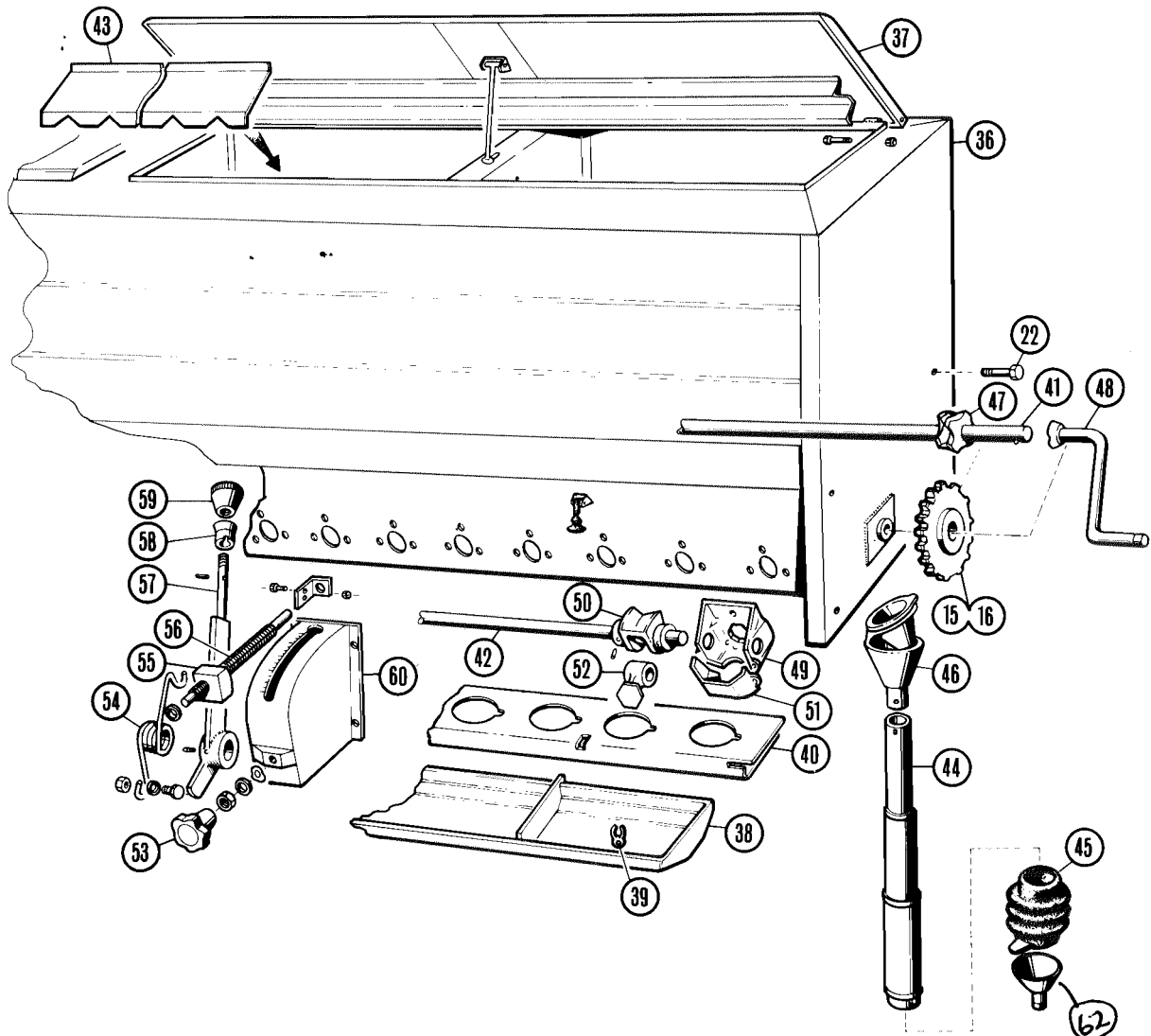

4M SEEDBOX & DRIVE UNIT

ITEM	PART NO.	DESCRIPTION	QTY.
1	350-0004	Seed Box Mounting Bracket R.H.	1
2	351-0004	Seed Box Mounting Bracket L.H.	1
3	313-1034	Support Arm Pivot Bracket	1
4	314-1234	Drive Wheel Support Arm - Upper	1
5	315-1234	Drive Wheel Support Arm - Lower	1
6	316-1234	Drive Wheel	1
7	317-1234	Drive Wheel Axle	1
8	318-1234	Drive Wheel Spacer	1
9	319-1234	Pivot Bracket Bearing Washer	1
10	360-0004	Chain Guard Cover - Large	2
11	361-0004	Chain Guard Cover - Small	1
12	322-0004	Chain Guard Lower	1
13	323-1234	9T Double Drive Sprocket	1
14	324-0004	16T Drive Sprocket Lower	1
15	325-1234	21T Drive Sprocket Upper	1
16	327-1034	34T Drive Sprocket Upper	1
17	329-1234	Chain Connecting Link	3
18	331-0004	76L Drive Chain - Lower	1
19	332-1034	70L Drive Chain - Upper	1
20	A106	M 20 x 70 Bolt	2
21	A111	M 12 x 55 Bolt	2
22	A112	M 12 x 45 Bolt	12
23	A121	M 10 x 40 Setscrew	1
24	A123	M 8 x 16 Setscrew	2
25	A132	3/4" UNF Lock Nut	2
26	A134	M 10 Wing Nut	4
27	A135	M 20 Lock Nut	2
28	A138	M 12 Lock Nut	8
29	A145	M 20 x 32 Washer - HD	2
30	A156	1 3/8" Timken Taper Roller Bearing	2
31	A157	1" Timken Taper Roller Bearing	4
32	A162	Acrometer	1
33	A163	Acrometer Link Arm	1
34	A182	Dust Cap - Small	1
35	A183	Dust Cap - Large	1
36	A217	Seed Box Shell	1
37	A227	Seed Box Lid	1
38	A237	Collection Tray/Cover	2
39	A342	Nylon Clip	4
40	A257	Seedcup Holder Unit	2
41	A267	Rotor Drive Shaft	1
42	A277	Distribution Shaft	1
43	A287	Anti Compaction Plate	2
44	A315	Flexible Seed Tube - 3T	24
45	A325	Seed Tube Joint 3T BELOW 3T	24
46	A330	Seed Cup Holder	24
47	A350	Feed Rotor	24
48	A360	Calibration Handle	1
49	A370	Distribution - Main Unit	24
50	A380	Distribution - Sluicgate Unit	24
51	A390	Distribution - Plastic Cover	24
52	A400	Distribution - Nylon Shutter	24
53	A410	Calibration - Hand Adjustment Screw	1
54	A420	Calibration - Spring	1
55	A430	Calibration - Adjustment Nut	1
56	A440	Calibration - Screw Thread	1
57	A450	Calibration - Pointer Shaft	1
58	A460	Calibration - Pointer Locator	1
59	A470	Calibration - Pointer Handle	1
60	A480	Calibration - Graduated Box	1
61	A493	Tension Spring	1
62	A326	SEEDTUBE JOINT	24