

W 400 - W 600

UNIDRILL-W

PLEASE READ CAREFULLY BEFORE USING THE MACHINE

August 2001

System
Moore

33 Kirk Road, Ballymoney, Co. Antrim,
Northern Ireland BT53 6PP.
Tel: (028) 2766 4444
Fax: (028) 2766 5696

Dear Customer



Thank you for trusting our equipment and choosing the UNIDRILL.

To Ensure correct operation, and make full use of your seed drill's capabilities, we recommend that you read this operators manual carefully.

Please do not hesitate to make suggestions or comments based on your experience; they will always be of use to us, and will help us improve our products.

Please return the duly completed guarantee form to us.

We wish you success with your seed drill.

Yours sincerely

Sam Moore
Managing Director

Guarantee Form



Moore Uni Drill Limited
33 Kirk Road, Ballymoney,
Co. Antrim, N Ireland, BT53 6PP
TEL: (++44) 028276 64444
FAX: (++44) 028276 65696
Email: info@moore-unidrill.com
Website: www.moore-unidrill.com

Machine Width: _____

Serial Number: _____

Customer Name: _____

Tel: _____

Address: _____

Mobile No: _____

Email: _____

Post Code: _____

I HAVE RECEIVED THE ABOVE MACHINE IN AN ACCEPTABLE
CONDITION AND TO THE CORRECT SPECIFICATION.

I HAVE RECEIVED AND READ THE OWNERS MANUAL FOR SAFE
AND CORRECT OPERATION OF MACHINE.

I WISH TO REGISTER MY MACHINE FOR WARRANTY.

SIGNED:- _____ *CUSTOMER* *DATE:-* _____

1. To be completed, detached and returned to Moore Uni Drill within 14 days of customer receipt / purchase.
2. It is essential that all details be completed.
3. Failure to complete and return this form will prevent claim settlement.

Declaration of Conformity



DECLARATION OF CONFORMITY

Moore Uni Drill Limited,
Of 33 Kirk Road, Ballymoney, Co. Antrim, N. Ireland. BT53 6PP
hereby declare that

Model
Serial No
Date

conforms with the following Directives and Regulations, and has been certified accordingly.

The Essential Health and Safety Regulations Directive. 98 - 37 - EC
The Proposed Seed Drills Safety Document 2000
(00 / 714171 DC)

Certified on behalf of Moore Uni Drill Limited

James A O' Kane

Design Engineer
Date: 17 - 05 - 2001

Safety Regulations



Risk of accident



Risk of damage to the machine



Operating tip

● These symbols are used in these instructions every time recommendations are provided concerning your safety, the safety of others or the correct operation of the machine.

● These recommendations must be given to all users of the machine.

GENERAL SAFETY REGULATIONS

Every time the tractor/machine assembly is to be started up and used, you should ensure beforehand that it complies with current legislation on safety at work and Road Traffic regulations.

GENERAL

- 1 - In addition to the instructions contained in this manual, legislation relating to safety instructions and accident prevention should be complied with.
- 2 - Warnings affixed to the machine give indications regarding safety measures to be observed and help to avoid accidents.
- 3 - When travelling on public roads, abide by the provisions of the Highway Code.
- 4 - Before starting work, it is essential that the user familiarizes himself with the control and operating elements of the machine and their respective functions. When the machine is running, it may be too late.
- 5 - The user should avoid wearing loose clothing which may be caught up in the moving parts.
- 6 - We recommend using a tractor with a safety cab or roll bar conforming to standards in force.
- 7 - Before starting up the machine and beginning work, check the immediate surroundings, particularly for children. Make sure that visibility is adequate. Clear any persons or animals out of the danger zone.
- 8 - It is strictly forbidden to transport any persons or animals on board the machine whether it is in operation or not.
- 9 - The machine should only be coupled up to the tractor at the specially provided towing points and in accordance with applicable safety standards.
- 10 - Extreme care must be taken when coupling or uncoupling the machine from the tractor.
- 11 - Before hitching up the machine, ensure that the front axle of the tractor is sufficiently weighted. Ballast weights should be fitted to the special supports in accordance with the instructions of the tractor manufacturer.
- 12 - Do not exceed the maximum axle weight or the gross vehicle weight rating.
- 13 - Do not exceed the maximum authorized dimensions for using public roads.
- 14 - Before entering a public road, ensure that the protective and signalling devices (lights, reflectors, etc.) required by law are fitted and working properly.
- 15 - All remote controls (cords, cables, rods, hoses, etc.) must be positioned so that they cannot accidentally set off any manoeuvre which may cause an accident or damage.

16 - Before entering a public road, place the machine in the transport position, in accordance with the manufacturer's instructions.

17 - Never leave the driver's position whilst the tractor is running.

18 - The speed and the method of operation must always be adapted to the land, roads and paths. Avoid sudden changes of direction under all circumstances.

19 - Precision of the steering, tractor adhesion, road holding and effectiveness of the braking mechanism are influenced by factors such as the weight and nature of the machine being towed, the front axle stage and the state of the land or path. It is essential, therefore, that the appropriate care is taken for each situation.

20 - Take extra care when cornering, taking account of the overhang, length, height and weight of the machine or trailer being towed.

21 - Before using the machine, ensure that all protective devices are fitted and in good condition. Damaged protectors should be replaced immediately.

22 - Before using the machine, check that nuts and screws are tight, particularly those for attaching tools (discs, flickers, deflectors, etc.). Tighten if necessary.

23 - Do not stand in the operating area of the machine.

24 - Caution! Be aware of any crushing and shearing zones on remote-controlled and particularly hydraulically-controlled parts.

25 - Before climbing down from the tractor, or before any operation on the machine, turn off the engine, remove the key from the ignition and wait until all moving parts have come to a standstill.

26 - Do not stand between the tractor and the machine until the handbrake has been applied and/or the wheels have been wedged.

27 - Before any operation on the machine, ensure that it cannot be started up accidentally.

28 - Do not use the lifting ring to lift the machine when it is loaded.

PROPER USE OF THE MACHINE

The Seed drill must only be used for tasks for which it has been designed.

The manufacturer will not be liable for any damage caused by using the machine for applications other than those specified by the manufacturer. Using the machine for purposes other than those originally intended will be done so entirely at the user's risk.

Proper use of the machine also implies:

- complying with instructions on use, care and

maintenance provided by the manufacturer; - using only original or manufacturer recommended spare parts, equipment and accessories.

The Seed drill must only be operated, maintained and repaired by competent persons, familiar with the specifications and methods of operation of the machine. These persons must also be informed of the dangers to which they may be exposed.

The user must strictly abide by current legislation regarding:

- accident prevention;
- safety at work (Health and Safety Regulations);
- transport on public roads (Road Traffic Regulations).

Strict compliance with warnings affixed to the machine is obligatory.

The owner of the equipment shall become liable for any damage resulting from alterations made to the machine by the user or any other person, without the prior written consent of the manufacturer.

The noise created by the machine does not exceed 70 decibels.

HITCHING

1 - When hitching or unhitching the machine from the tractor, place the control lever of the hydraulic lift in such a position that the lifting mechanism cannot be activated accidentally.

2 - When hitching the machine to the three-point lifting mechanism of the tractor, ensure that the diameters of the pins or gudgeons correspond to the diameter of the tractor ball joints.

3 - Caution! In the three-point lifting zone, there may be a danger of crushing and shearing.

4 - Do not stand between the tractor and the machine whilst operating the external lift control lever.

5 - When in transport, lifting mechanism stabilizer bars must be fitted to the machine to avoid floating and side movement.

6 - When transporting the machine in the raised position, lock the lift control lever.

DRIVE EQUIPMENT

(Power take-off and universal drive shafts)

1 - Only use universal drive shafts supplied with the machine or recommended by the manufacturer.

2 - Power take-off and universal drive shaft guards must always be fitted and in good condition.

3 - Ensure that the tubes of the universal drive shafts are properly guarded, both in the working position and in the transport position.

4 - Before connecting or disconnecting a universal drive shaft, disengage the power take-off, turn off the engine and re-move the key from the ignition.

5 - If the primary universal drive shaft is fitted with a torque limiter or a free wheel, these must be mounted on the machine power take-off.

6 - Always ensure that universal drive shafts are fitted and locked correctly.

7 - Always ensure that universal drive shaft guards are immobilized in rotation using the specially provided chains.

8 - Before engaging power take-off, ensure that the speed selected and the direction of rotation of the power take-off comply with the manufacturer's instructions.

9 - Before engaging power take-off, ensure that no persons or animals are close to the machine.

10 - Disengage power take-off when the universal drive shaft angle limits laid down by the manufacturer are in danger of being exceeded.

11 - Caution! When power take-off has been disengaged, moving parts may continue to rotate for a few moments. Do not approach until they have reached a complete standstill.

12 - On removal from the machine, rest the universal drive shafts on the specially provided supports.

13 - After disconnecting the universal drive shafts from the power take-off, the protective cap should be fitted to the power take-off.

14 - Damaged power take-off and universal drive shaft guards must be replaced immediately.

HYDRAULIC CIRCUIT

1 - Caution! The hydraulic circuit is pressurized.

2 - When fitting hydraulic motors or cylinders, ensure that the circuits are connected correctly in accordance with the manufacturer's guidelines.

3 - Before fitting a hose to the tractor's hydraulic circuit, ensure that the tractor-side and machine-side circuits are not pressurized.

4 - The user of the machine is strongly recommended to identify the hydraulic couplings between the tractor and the machine in order to avoid wrong connection. Caution! There is a danger of reversing the functions (for example: raise/lower).

5 - Check hydraulic hoses once a year:

- . Damage to the outer surface
- . Porosity of the outer surface
- . Deformation with and without pressure
- . State of the fittings and seals

The maximum working life for hoses is 6 years.

When replacing them, ensure that only hoses with the specifications and grade recommended by the machine manufacturer are used.

6 - When a leak is found, all necessary precautions should be taken to avoid accidents.

7 - Pressurized liquid, particularly hydraulic circuit oil, may cause serious injury if it comes into contact with the skin. In the case of injury, consult a doctor immediately. There is a risk of infection.

8 - Before any operation on the hydraulic circuit, lower the machine, release the pressure from the circuit, turn off the engine and remove the key from the ignition.

4 - When replacing a working part (fertilizer spreader blade or seed drill coulter), wear protective gloves and only use appropriate tools.

5 - To protect the environment, it is forbidden to throw away oil, grease or filters of any kind. Give them to specialist recycling firms.

6 - Before operating on the electric circuit, disconnect the power source.

7 - Protective devices likely to be exposed to wear and tear should be checked regularly. Replace them immediately if they are damaged.

8 - Spare parts should comply with the standards and specifications laid down by the manufacturer.

Only use Moore spare parts

9 - Before commencing any electric welding work on the tractor or the towed machine, disconnect the alternator and battery cables.

10 - Repairs affecting parts under stress or pressure (springs, pressure accumulators, etc.) should be carried out by suitably qualified engineers with special tools.

MAINTENANCE

1 - Before commencing any maintenance, servicing or repair work, or before attempting to locate the source of a breakdown or fault, it is essential that the power take-off is disengaged, the engine turned off and the key removed from the ignition.

2 - Check regularly that nuts and screws are not loose. Tighten if necessary.

3 - Before carrying out maintenance work on a raised machine, prop it up using appropriate means of support.

DANGER

- 1** Side marker operating zone
- 2** Moving parts
- 3** Do not travel on the platform
- 4** Rotating agitator shaft
- 5** Risk of pinching or crushing

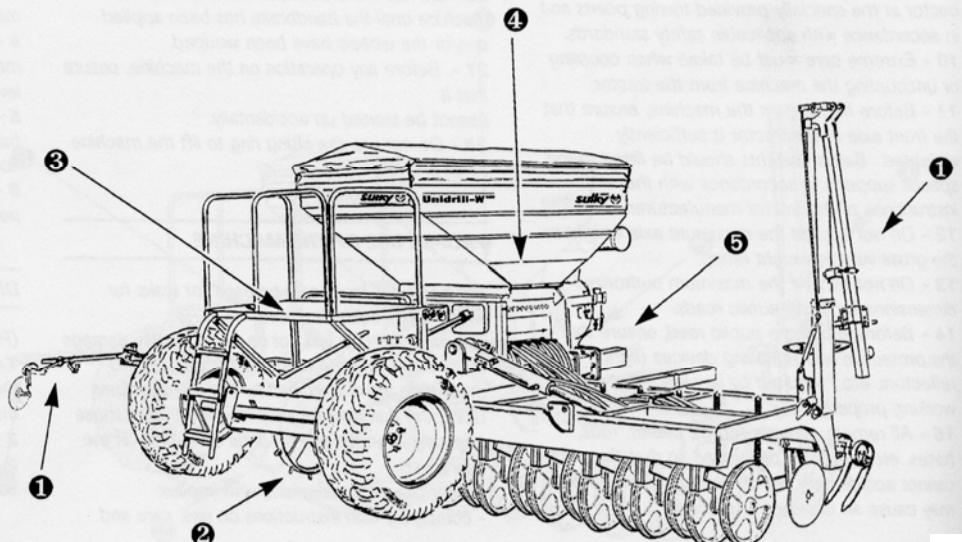

Warning Symbols 1

All Safety decals on the machine must be kept in good readable condition. If they are not replacements are available from Moore Unidrill. Part Numbers are shown under each symbol

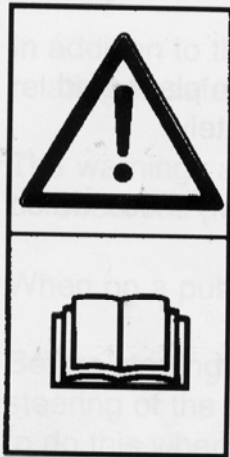

Carefully read operator's manual before handling the machine. Observe instructions and safety rules when operating.

SD 01



Stay a safe distance from the machine.

SD 02



Insert safety lock before getting into hazardous area.

SD 03



Never reach into rotating auger.

SD 04



Never reach into the crushing danger area as long as parts may move.

SD 05



Do not ride on platform or ladder.

SD 06

Warning Symbols 2

SD 07

Tighten implement wheel studs after the first 4 working hours and then daily thereafter

Ensure wheel nuts are tight

SD 08



DANGER
TRANSPORT PINS MUST BE USED BEFORE WORKING ON THE MACHINE WHILST IN THE RAISED POSITION

Ensure transport pins are used when working under raised machine

SD 09



Do not work under raised marker

SD 10



OPERATOR INFORMATION
IT IS THE RESPONSIBILITY OF THE DRILL OPERATOR TO CHECK THE TRAMLINE IS FUNCTIONING IN THE CORRECT SEQUENCE, AFTER EVERY HOPPER REFILL, AND ALSO ENSURE THE TRAMLINE SYSTEM FUNCTIONS IN THE CORRECT SEQUENCE WITH THE DRILLING TRACTORS 12V POWER SOURCE.

Ensure the tramline system is functioning correctly after each fill

SD 11

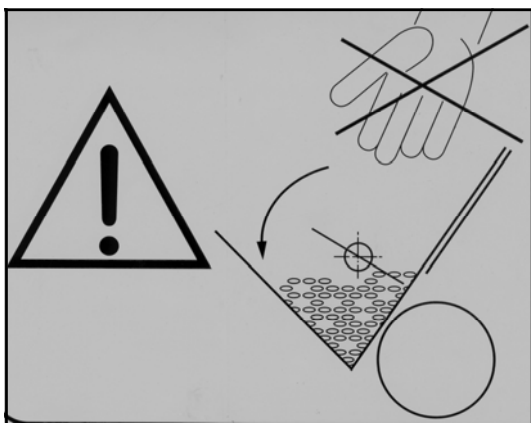

Never reach into rotating auger

SD 12

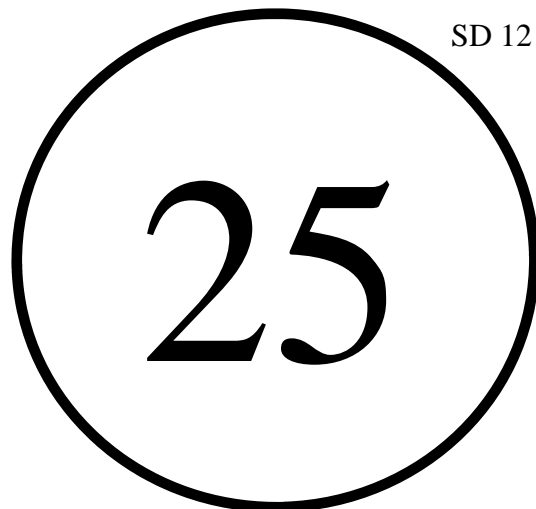

Forward speed should not exceed 25 KPH

Safety / Instruction Decals



Safety / Instruction Decals

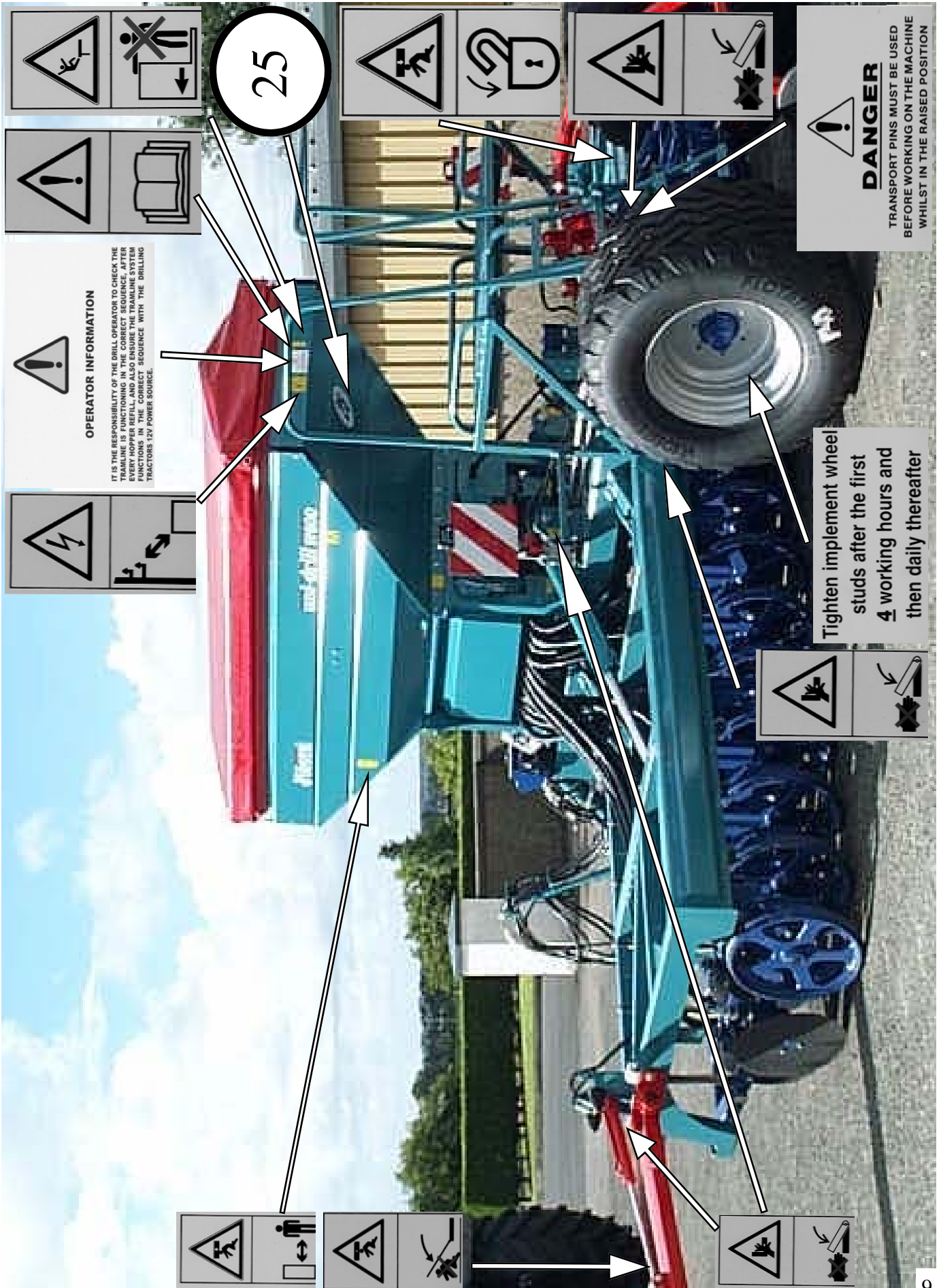

Technical Specifications

Identification

When accepting ownership of your machine note the following information:

Serial Number: _____

Type of machine: _____

Accessories: _____

Technical Specifications

MOORE UNIDRILL	W400	W600
Width (m)	4	6
Number of rows	24	36
Row spacing (cm)	16.6	16.6
Width in transport (m)	3	3
Hopper capacity (l)	1600	2000
Weight (Kg)	3750	5760
Horse Power Required (HP)	130	180

Contents

Acknowledgments	1
Guarantee Form	2
Declaration of conformity	3
Safety Regulations	4 - 5
Warning Symbols 1	6
Warning Symbols 2	7
Safety / Instruction Decals	8 - 9
Technical Specifications	10
Contents	11 - 12
SECTION 1 STARTING UP	
- Tractor Requirements	13
- Preparation. (Attaching the drill to the tractor)	14
- Hitching	15
- Transport, Hydraulic connections	16
- Fan Unit. (PTO)	17 - 18
- Fan Unit. (Hydraulic)	19 - 20
- Seedbox	21
- Calibration, running in, seedbed preparation	22
SECTION 2 SETTINGS	
- Sowing Rate Settings	23
- Distribution shutter, Base flap	24
- Selecting the peg wheel, variator	25
- Preparing calibration test	26
- Carrying out calibration test	27 - 28
- Testing with the calculator	29
- Sowing Depth - Depth Segments / Memory Cylinder	30 - 31
- Coulter height setting, tilt setting adjustment	32
- Side Markers	33
- Side marker safety	34
- Half width shut-off, Emptying the hopper	35
- Moore Expert Headland Drill Control Unit	36 - 49
SECTION 3 OPERATION	
- Field operation, work rate, Drilling into a conventional seedbed	50
- Drilling in wet conditions, Drilling into trashy conditions, Min tillage, Direct drilling	51
- Direct drilling grass, preventing soil compaction	52
- Burying the straw	53
- Other Suggestions	54

SECTION 4	MAINTENANCE	- Points 1 - 12	55
		- Cleaning, Servicing Intervals, Greasing, Lubrication	56 - 58
		- Checking and setting disc coulters	59
		- Checking for signs of wear, Tyre pressures	60 - 61
SECTION 5	OPTIONAL EQUIPMENT		
		- MS Flow modulation. Starting up / Operation	62 - 70
		- Variator / Multiplier	71 - 73
		- Electro diverter valve	74 - 75
		- Pre Emergence Marker	76
		- Hydraulic or Air Brakes	77
		- Seedbox Extension / Hopper Cover	78
SECTION 6	PARTS LIST	- Notes	79
		- Dragarm seeding unit	80 - 81
		- Dragarm axle units. Arable	82 - 83
		- Drawbar, Rear axle and Chassis Assembly W400 / W600	84 - 87
		- Drive wheel assembly	88 - 89
		- Angle Gearbox Drive Unit	90 - 91
		- Seedbox drive unit	92 - 93
		- Multiplier	94 - 95
		- MS Flow Modulation.	96 - 97
		- Headland Splitter Gearbox	98 - 99
		- Seedbox Metering Parts	100 - 101
		- Seedbox assembly	102 - 103
		- Seed Hopper Extension	104 - 105
		- Seed Hopper Cover	106 - 107
		- PTO / Hydraulic Fan Parts	108 - 111
		- Rear Platform	112 - 113
		- Moore Solo Markers	114 - 115
		- Pre Emergence Marker	116 - 117
		- 4M & 6M Hydraulic hoses and fittings	118 - 119
		- Moore Expert Hydraulic hoses and fittings	120 - 121
		- Electrical Parts - Chassis	122 - 123
		-Electrical Parts - Sensors	124 - 125
SECTION 7	CALIBRATION CHARTS		
		- Available pre set reminders	126
		- Table 1. Recommended shutter, base flap and peg wheel positions	127
		- Calibration charts for wheat. Worked example	128
		- Calibration charts for rape, barley, peas and field beans	129
		- Calibration charts for oats, mustard, phacelia and radish	130
		- Calibration charts for lucern, linseed, rye grass and clover	131
	Notes / Warranty		132 - 133

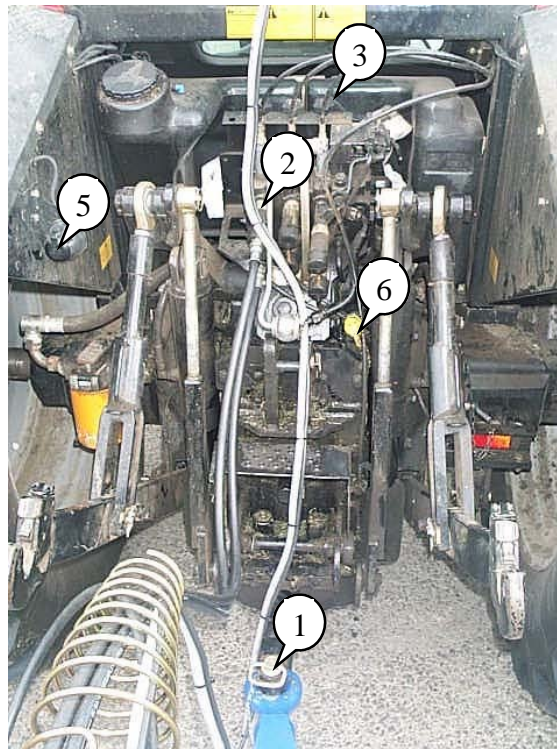

TRACTOR REQUIREMENTS

- | | |
|---|---|
| <p>1). (A) If the drill is fitted with a hydraulic fan the Pickup Hitch should be used.</p> <p>(B) If the drill is fitted with a PTO fan the Clevis Drawbar should be used.</p> <p>2). (A) If the drill is fitted with a hydraulic fan, four female quick release couplings are required. The return hose from the fan has a male probe with a ball end. This return line should be freeflow to tank. IE the oil returns directly to the tank and not back through the valve stack.</p> | <p>2). (B) The Hydraulic fan must be stopped in the float position on the spool valve lever. This allows that fan to slow down at its own speed. If the fan is stopped instantly from its working speed it will become dead headed causing severe damage to the fan motor and manometer clock.</p> <p>2). (C) If the drill is fitted with a PTO fan, two female quick release couplings are required.</p> <p>3). The fan speed can be regulated using the flow control valve on the spool block</p> <p>4). One 12 Volt Electrical supply. (Euro plug)</p> <p>5). One 7 Pin lighting socket</p> <p>6). One hydraulic brake hose connection</p> |
|---|---|

Starting up

A. PREPARATION. (Attaching the drill to the tractor)

- 1) Reverse the tractor up to the drill lining up the hitch of the tractor to the hitch of the drill.
- 2) If the drill has a Hydraulic fan the Pickup Hitch should be used.
If the drill has a PTO fan the Clevis Drawbar and tow pin should be used.
- 3) If PTO Fan is fitted attach the PTO Shaft to the tractor.
- 4) Plug the hydraulic feed hose for the 6 port valve block into a suitable hydraulic spool valve. The pressure line into this valve block is the line marked “P” and is denoted with a red probe cover.
- 5) Plug the hydraulic return hose for the 6 port Electro Hydraulic Valve block into the companion coupling of the above spool valve. The return line from this valve block is marked “T” and is denoted with a blue probe cover.
- 6) If Hydraulic fan fitted.
 - (A) Plug the hydraulic feed hose for the hydraulic fan motor into a motor spool valve. The feed hose is the hose without the ball end probe. Ensure the flow control valve is set to minimum before starting the fan.
 - (B) Plug the hydraulic return hose into the return port of the motor spool valve. The return hose is the hose with the ball end probe. The return line should be freeflow to tank. Back pressure will be created if the proper coupler is not used with ball nose probe.
- 7) Plug the 7 pin lighting plug into the 7 pin socket on the tractor.
- 8) Place the electronic box (Moore Expert) in the tractor cab and secure to the glass in an appropriate place using the suction pad on the rear.
- 9) Screw the 37 pin socket on the electronic box and the 37 pin plug on the machine together. Connect the control box to the tractor euro socket. **There must be a good 12V Supply to the control box.**
- 10) Connect the power lead from the electronic box to the power lead from the tractor euro socket using the 2 spade plug.
- 11) Check that all above functions operate correctly.

Starting up

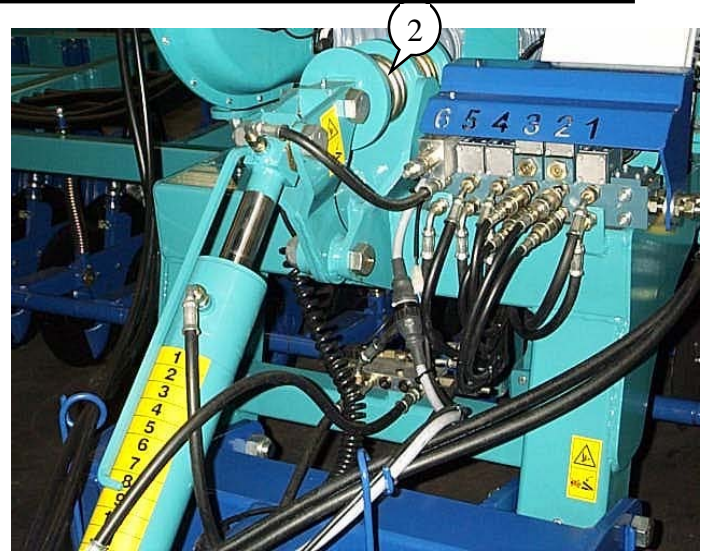
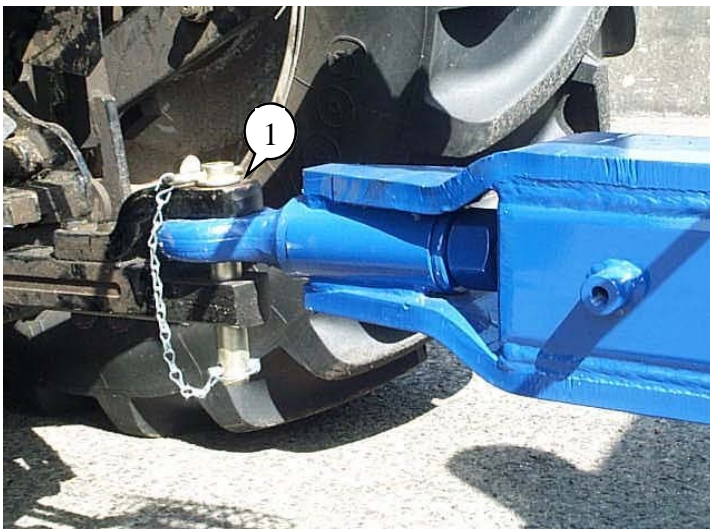

NOTE:

- The pick-up hitch should be used when the drill is fitted with a hydraulic fan.
- The clevis drawbar should be used when the drill is fitted with a PTO fan.

HITCHING

Hitching Height

The height of the hitching point greatly affects the machine's correct operation (+/- 450 mm)

- The hitching point must importantly be fixed. The lower linkage bar cannot be used in this case.
- Low hitching heights should be preferred, such as the pick up hitch or clevis drawbar **(1)** especially for direct sowing.
- The clevis drawbar is recommended when using dual wheels or wide tyres to make manoeuvres at the field ends easier

Drawbar suspension unit

The drawbar suspension unit **(2)** consists of two springs which help to maintain a constant drilling depth, regardless of the position of the tractor wheels, ie if the tractor wheels fall into a hollow, this will not affect the seeding depth.

Starting up



Safe Working Area

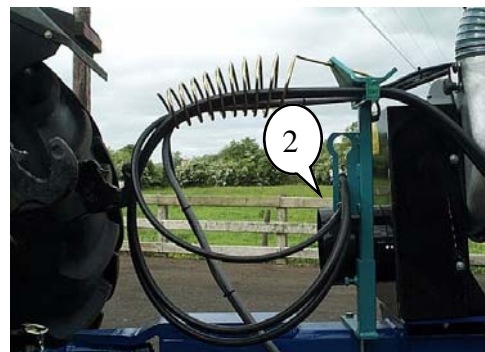
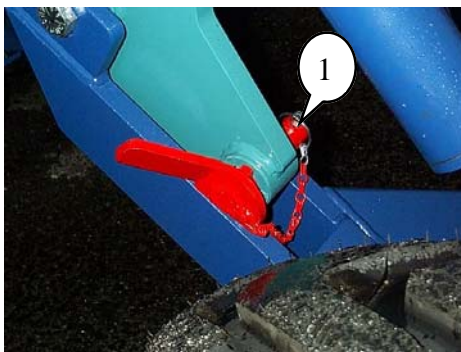

The user must comply with road traffic regulations. The hopper should be empty when driving on the road at a maximum speed of 25 KPH.

TRANSPORT

Positioning the pins (1) in their transport position.

- Raise the seed drill
 - Insert the locking pins
 - Lower the machine so that it rests on the pins.
- In the interests of health and safety, the transport pins must be inserted from the side of the drill as shown. The operator must stay in the safe working area at all times. **At no time should the operator be under the rear platform.**

HYDRAULIC CONNECTIONS

- 1). (A) If the drill is fitted with a hydraulic fan, four female quick release couplings are required. The return hose from the fan has a male probe with a ball end. This return line should be freeflow to tank.
- 1). (B) If the drill is fitted with a PTO fan, two female quick release couplings are required.

NOTE: The Pressure line is marked with a Red probe cover .

The return line is marked with a blue probe cover.

Install the hydraulic hoses on the support (2)

Starting up

1.

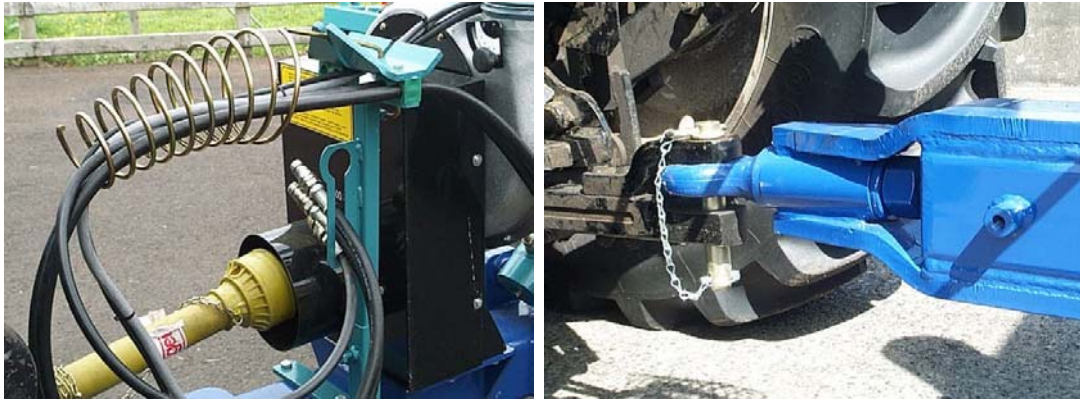

FAN UNIT PTO Fan

- Ensure the drill is attached to the clevis drawbar when using the PTO Fan Unit.
- Work the fan on the 1000 rpm PTO Shaft
- When working the fan maintain constant engine speed.
- Engage the PTO at engine idling speed.

NOTE: Before using the drill for the first time, you may need to adjust the length of the PTO shaft to allow enough free movement to prevent damage while towing. When cutting the Drive Shaft to suit the tractor, it must be cut short enough to provide sufficient clearance when the tractor and drill are travelling over uneven ground (Note Diagram).



High Ground

High Ground

The PTO Shaft is at its shortest when the tractor and drill are in the position shown. The PTO shaft must have 75 - 100 mm (3 to 4 Inches) of clearance in this position. Failure to cut the PTO Shaft to the correct length will cause severe damage to the Fan Unit.

PTO Shaft cutting instructions can be found on the following page.

Starting up

PTO Shaft cutting Instructions

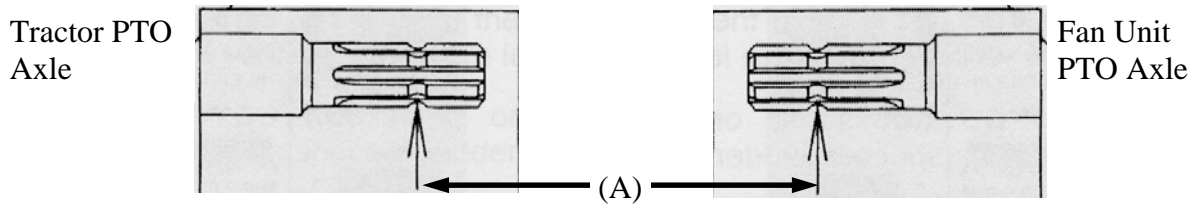

Measure Distance (A) between the grooves on the splined PTO attachment shafts on both the tractor and the drill.

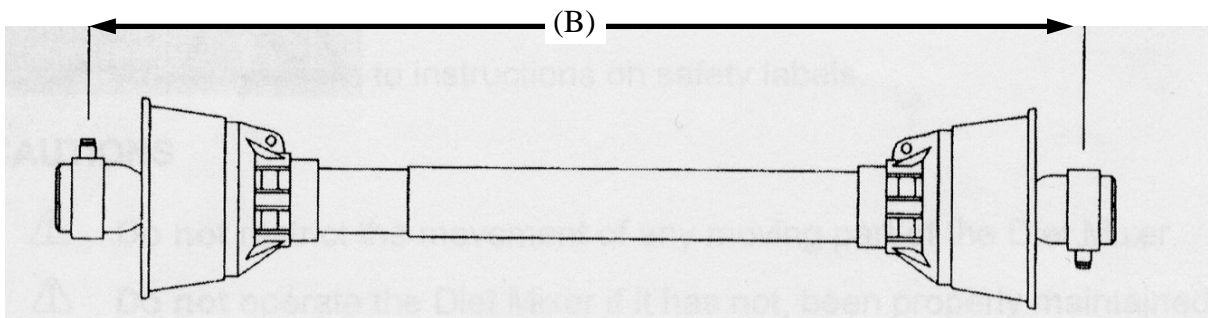

Measure the length (B) of the PTO shaft, between the locating buttons when it is in the fully closed position.

Dismantle the PTO shaft and cut both the inner and outer components so that dimension (B) is approximately 100mm or 4 Inches less than dimension (A), when the shaft is in the fully closed position.

Starting up

2.



FAN UNIT Hydraulic Fan Unit

The use of the hydraulic fan is dependant upon the tractor specification. Ideally the tractor should be fitted with a motor spool. (Consult your dealer)

1. The oil flow necessary to operate the fan is around 30 litres per minute.
2. The oil pressure rises to 180 bar when starting.
3. **The return oil pressure must not exceed 15 bar otherwise extensive damage will be caused to the fan.**
4. When using a tractor with open centre hydraulics, use the oil flow regulator on the tractor to control the speed of the fan and free flow the oil back to tank. If there is no flow regulator on the tractor, an inline flow regulator will be required for the fan., again free flow the oil back to tank.
5. When using a tractor with closed centre hydraulics (John Deere) use a series 3 SCV Valve (Motor spool). If this is not fitted refer to your John Deere dealer.
6. When using the spool lever to control the hydraulic fan consider the points listed below.
 1. Engage the fan N to P
 2. Disengage the fan P to F
 3. To get the tractor back to N stop the engine and return manually.

Key: T = Tank
N = Neutral
P = Pressure
F = Float

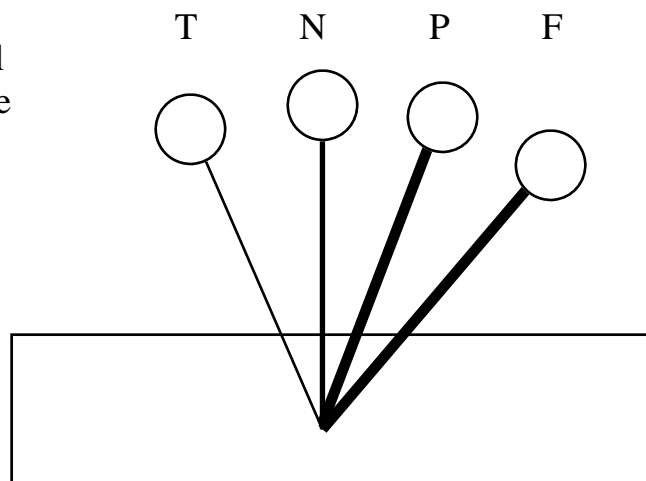

NOTE: Replacement seals for the fan motor are very expensive.

Starting up

2.



FAN UNIT Hydraulic Fan - Continued

Spool Valve Operation.

6. Clean the hydraulic spool valve connections before attachment to the tractor.
7. When operating the fan for the first time each day, the fan will be set to operating speed when the oil is cold. As the oil heats up to operating temperature the fan speed increases slightly as the oil becomes thinner. The original setting when the oil was cold will need to be corrected.
8. A Reading for the speed of rotation of the fan can be obtained from the Moore Expert control pod.
9. Tractor hydraulic connections.
The Pressure line to the fan has a push / pull probe on the end of the hose.
The Return line from the fan to the tractor must have a ball end probe on the hose. This line must ideally be “free flow” back to tank.



Starting up



SEEDBOX

- Use the ladder (1) on the rear platform to access the seedbox.
- Ensure the grille (2) has been placed in the seedbox to prevent foreign bodies from entering the seed metering mechanism.
- Always travel with the hopper cover (3) closed.

Starting up

A. CALIBRATION

Calibrate the seeding mechanism for seeds to be sown as in Section 2. Settings.

B. RUNNING IN

If the drill is new and is to be used in cultivated soil, it is better to “run-in” the drill in hard ground, such as a grass field. It is easier to work off the paint and rough edges from the seed tube coulters and discs when working in firm ground as there is more friction to turn the discs. This only requires a few turns across a field without seed. The depth control of the Uni-Drill can be tried out by retracting or extending of the depth control ram to increase or decrease the depth of penetration. Check that all discs turn relatively freely; it may be necessary to slacken off seed tubes that are rubbing tight against the discs.

Settings

MOORE HEADLAND & DRILL CONTROL UNIT

A. INTRODUCTION

The Moore Headland & Drill Control instrument utilises Expert series hardware to perform the standard Multi Function Drill Control functions of the existing UDM J and also control the operation and sequencing of electro-hydraulic valves on the drill.



Control Box

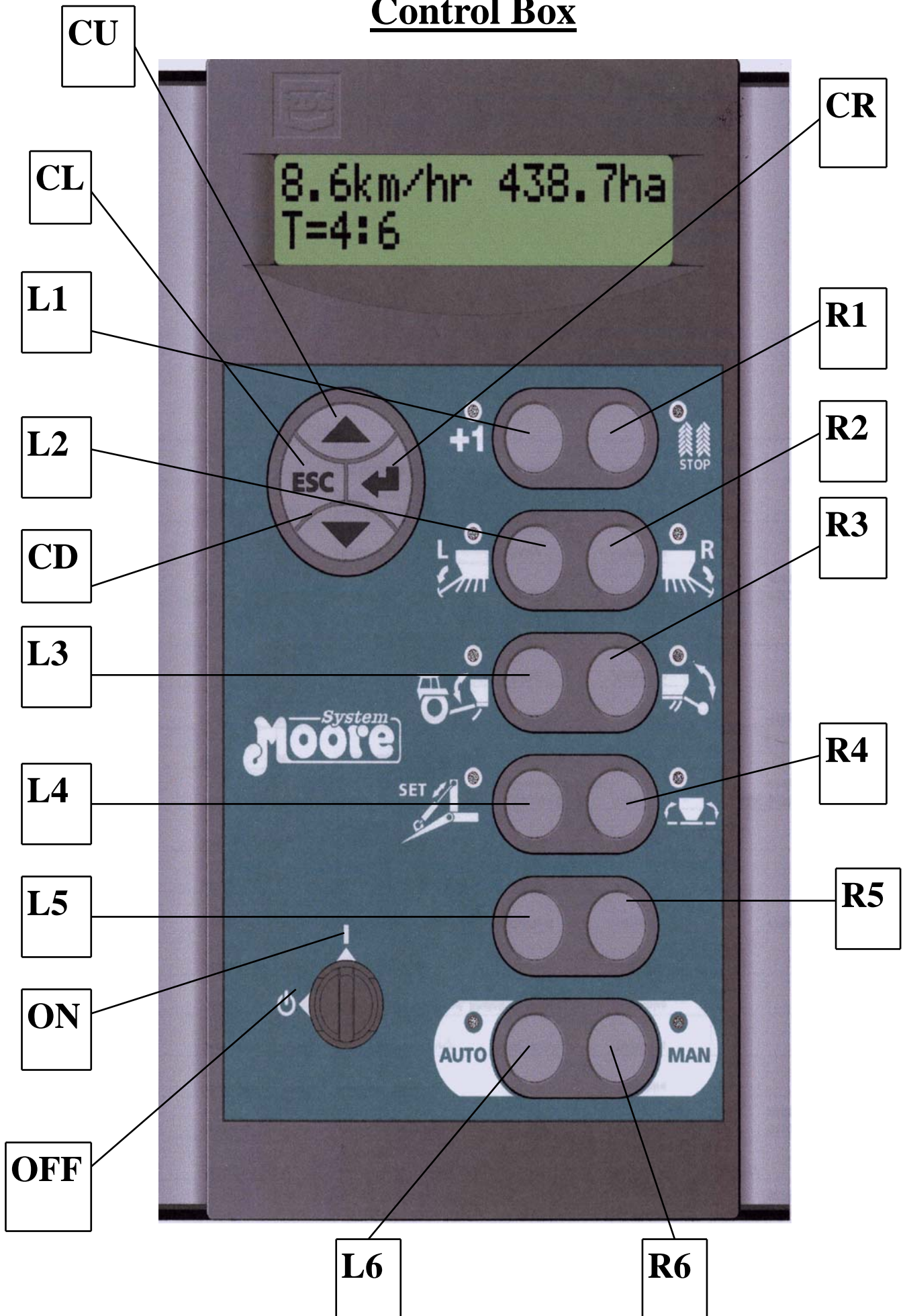

OPERATION

The following indicates which operation each key performs.

Keys L1, R1, CU, CD, CL and CR are concerned with Multifunction Drill Control only.

Keys L2,L3, L4, L5, L6, R2, R3, R4, R5, R6 are concerned with Electro Hydraulic Control of Hydraulic Valves on the drill.

KEY L1

When pressed, this is the manual bout step.

KEY R1

When pressed in either Auto or Manual, the current bout is held and cannot be advanced with either key L1 or by the tramline advance sensor on the rear axle..

KEY CU

This key is used to scroll through the menus.

KEY CD

This key is used to scroll down through the menus.

KEY CR

This key is used to enter changes you have made to the menu.

KEY CL

This key is used to exit the menu that you are currently in.

KEY L2 Left Marker Solenoid

When pressed in Manual Mode, it will engage the Left Marker Solenoid, pressing again will turn off the Left Marker Solenoid.

KEY R2 Right Marker Solenoid

When pressed in Manual Mode, it will engage the Right Marker Solenoid, pressing again will turn off the Right Marker Solenoid.

KEY L3 Draw Bar Solenoid

When pressed in Manual Mode, it will engage the Drawbar Solenoid, pressing again will turn off the Drawbar Solenoid.

KEY R3 Rear Axle Solenoid

When pressed in Manual Mode, it will engage the Rear Axle Solenoid, pressing again will turn off the Rear Axle Solenoid.

KEY L4 Memory Cylinder Set Solenoid

When pressed in Manual Mode, it will turn on the Memory Cylinder Set Solenoid, pressing again will turn off the Memory Cylinder Set Solenoid.

NOTE: When setting the Memory Cylinder, always use the following sequence as illustrated on page 31.

KEY R4 Wings Set Solenoid

When pressed in and held in Manual Mode, the Wing Fold Solenoid will be engaged when the drill is fully lifted. Releasing Key R4 turns off the Wing Fold Solenoid.

NOTE: Key R4 must be pressed in and also held in, before the solenoid will become energised.

NOTE: Electrical Solenoids may occasionally “Stick” and will not energise. It is possible to manually override this by pushing the brass plunger at the back of the solenoid with a screwdriver. Ensure the current is disconnected and that there is no oil pressure in the system.

KEY L5

No function.

KEY R5

No function.

Key L6

When pressed 'manual' mode is selected, in this mode, this allows independent control of the hydraulic services.

KEY R6

When pressed, the Auto Sequence is enabled which will Automate your headland turn.

The operator can control the way in which the markers are required to work in the auto sequence.

If the markers are not required, the operator should select auto, with no other functions on the display illuminated.

If both markers are required on the first bout, the operator should press both markers in manual mode, **then press auto**. And begin the auto sequence. When the operator has reached the end of the first drilling bout, lift the drill up full, and then select the marker that is required on the following bout, before lowering the drill back into work. And then continue on.

If the operator wants to begin drilling with the marker extend, which will mark the next drilling bout, the appropriate marker should be selected in manual mode, **then press auto**. and lower the drill into the first bout, the Moore Expert will then control the markers from then on.

Note : The tramline count is taken from the rear axle, so if you have to lift the drill during a drilling bout always press **stop** (Key R1) to hold the tramline count.

Whilst in a drilling bout and you need to independently adjust one of the drill functions, e.g. memory cylinder, press the manual button, then press memory cylinder button, adjust with the spool lever, when the desired position is reached, press memory cylinder button again, and press auto again, to get back into the bout sequence.

E.

MAIN OPERATING MODE

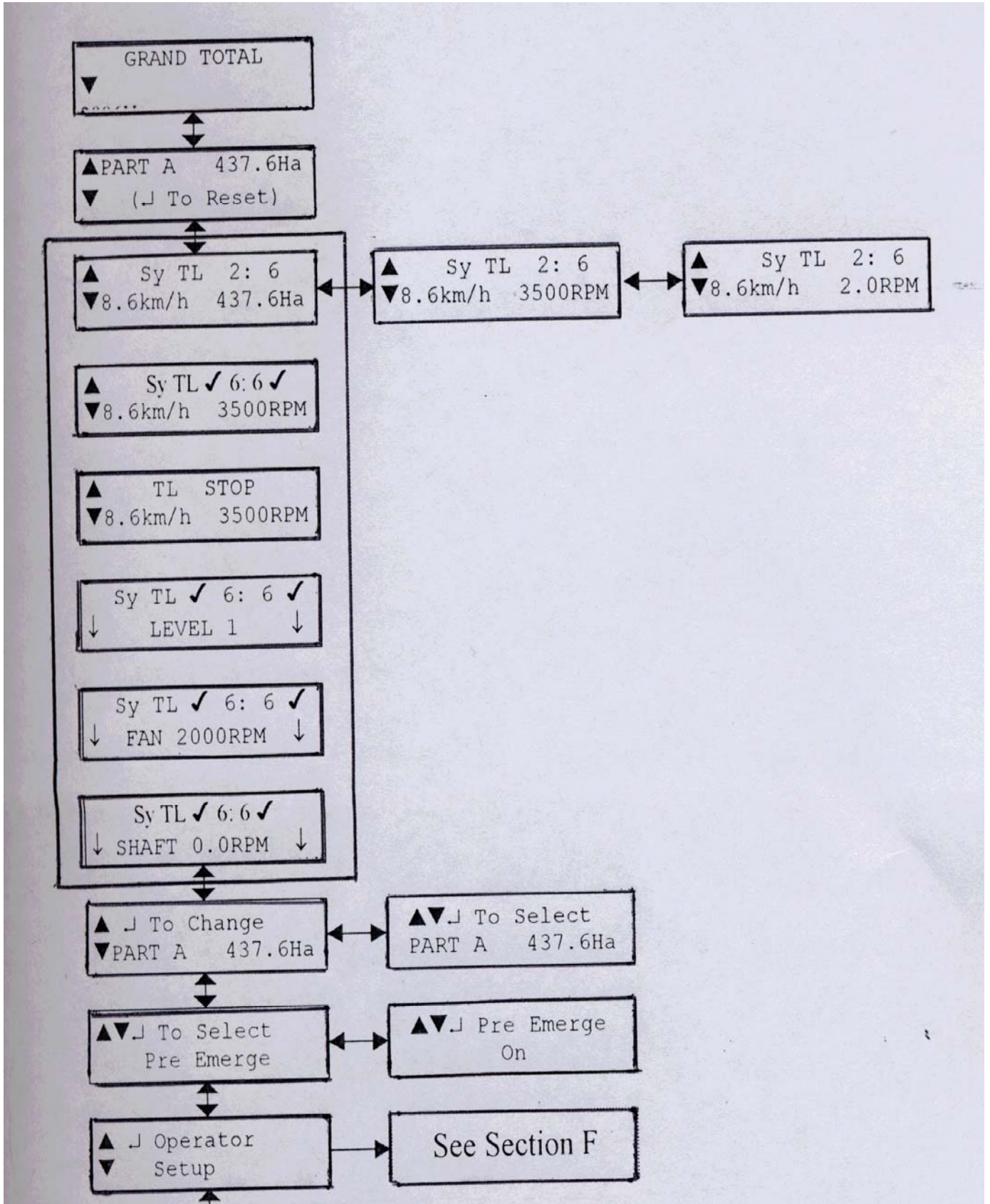

E.1

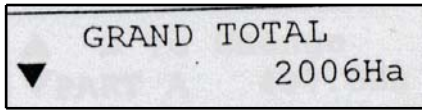

This is the non-reset able instruments accumulation of area. Resolution to 1 Ha.

E.2

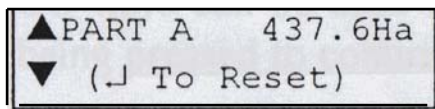

This screen shows the Part area total on register A. Press the CR Key to reset the register to zero.

E.3

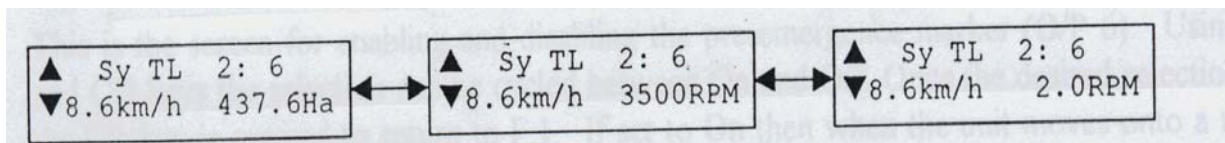

This is the conventional main operating display that the instrument will default to after 30 seconds from any of the other operating displays shown in section E. To cycle between the above 3 variations simply use the CR Key.

The top line of the display always shows the tramline status. 'Sy' indicates that rhythm is symmetrical. If the rhythm selected was asymmetric left than 'AL' would be shown, 'AR' for asymmetric right and '18 m' for the 18 metre rhythm. '2' is the current bout number and '6' is the target bout number. When upon a tram lining bout ticks will be sent to the left of the current bout number and to the right of the target bout number to indicate the outputs being on. If the rhythm is asymmetric left then only a left tick will be shown at the last and first bout of the sequence, vice versa if the rhythm selected is asymmetric right.

By cycling through the 3 displays the only information to change is that in the bottom right-hand corner. This could be the area register , the fan speed or the metering shaft speed .

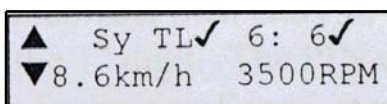

The above screen shows the ticks indicating both left and right outputs (O/P's 1 & 2) are switched on, as the current bout matches the target bout.

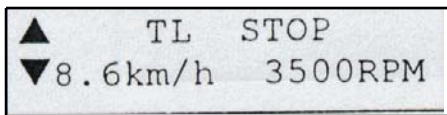

This screen shows that Key R1 has been pressed and the tramline count by I/P 5 has been stopped. This display will alternate between this and the normal display of tramline status on a 1 second basis. This will remain until Key R1 is pressed again.

E.4

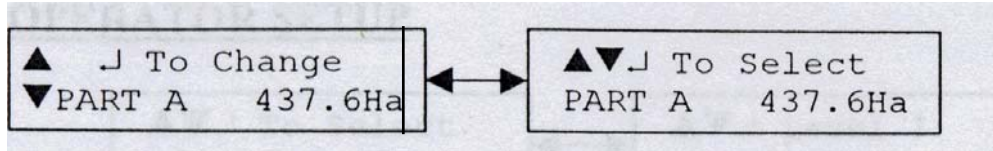

Press the CR Key on this screen allows the area register selected to be changed. Once this key has been pressed, the area register digit flashes opposite to the cursor below it and the CU and CD Keys can be used to cycle through the selection of registers from A - F, with the CR Key being pressed to confirm the selection.

E.5

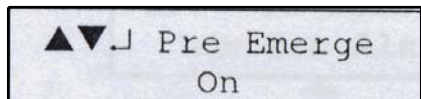

This is the screen for enabling and disabling the pre-emergence marker (O/P 6). Using the CU and CD Keys the selection can be cycled between On and Off. Once the desired selection is made the CR Key is pressed to return to F.1. If set to On then when the unit moves onto a tram lining bout, O/P 6 will be operated as well as O/P's 1 & 2.

E . 6

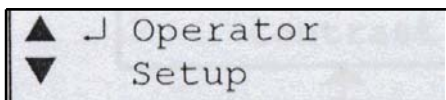

Pressing the CR Key at this screen will move you into the 'Operator Set-up' menu, see section f.

F.

OPERATOR SETUP

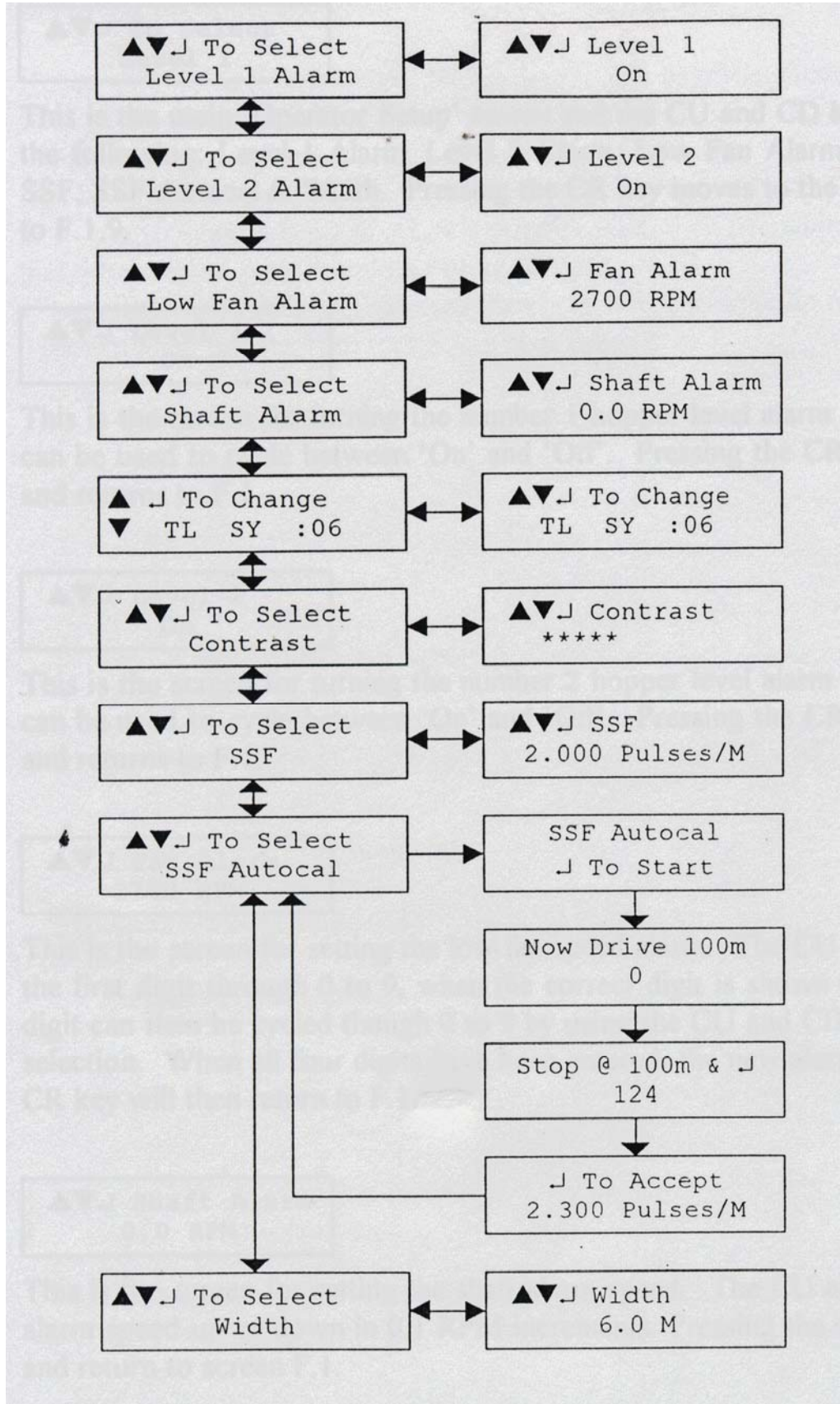

F.1

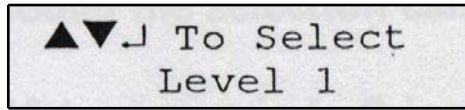

This is the main 'Operator Set-up' screen and the CU and CD Keys can be used to cycle through the following: Level 1 Alarm, Level 2 Alarm, Low Fan Alarm, Shaft Alarm, TL Set, Contrast, SSF, SSF Auto cal and Width. Pressing the CR Key moves to the required screen, see section F.1.1 to F.1.9.

F1.1

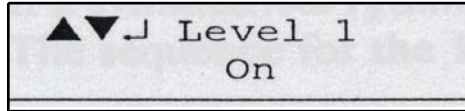

This is the screen for tuning the number 1 hopper level alarm On and Off. The CU and CD Keys can be used to cycle between 'On' and 'Off'. Pressing the CR Key confirms the selection made and returns to F.1.

F1.2

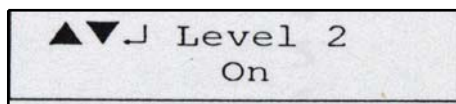

This is the screen for turning the number 2 hopper level alarm On and Off. The CU and CD Keys can be used to cycle between 'On' and 'Off'. Pressing the CR Key confirms the selection made and returns to F.1.

F1.3

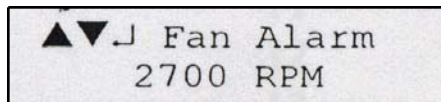

This is the screen for setting the low fan speed alarm. The CU and CD Keys can be used for cycling the first digit through 0 to 9, when the correct digit is shown the CR Key is pressed. The next digit can then be cycled through 0 to 9 by using the CU and CD Keys, the CR Key confirming the selection. When all four digits have been entered, the new alarm speed will be seen, pressing the CR Key will then return to F.1.

F1.4

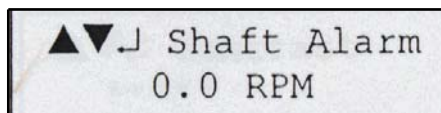

This is the screen for setting the shaft alarm speed. The CU and CD Keys are used to cycle the alarm speed up or down in 0.1 RPM increments. Pressing the CR Key will confirm the speed set and return to screen F.1.

F.1.5

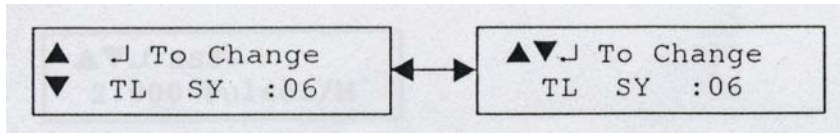

Pressing the CR Key on this screen allows the tramline rhythm selected to be changed. Once this key has been pressed, the type of rhythm flashes opposite to the cursor below it. The CU and CD Keys can be used to cycle through ‘SY’ (Symmetrical), ‘AL’ (Asymmetric Left), ‘AR’ (Asymmetric Right) and ‘18 m’ (the 18 m rhythm). Once this selection has been confirmed with the CR Key the target number of bouts will then flash opposite to the cursor below it. The target number can be scrolled up and down using CU and CD Keys between 01 and 12. Once the desired number is found the selection can be confirmed using the CR Key.

If Asymmetric Left is selected, then output T/L 1 only is switched on for the last bout and the first bout of sequence.

If Asymmetric Right is selected, then output T/L 2 only is switched on for the last bout and the first bout of the sequence. E.g. If a tram lining bout of AL 6 is programmed, then tram lining will be engaged on both bouts 1 and 6 on the left-hand tramline output (output T/L 1).

If a Symmetrical rhythm is selected then both outputs come on for only the tram lining bout.

The sequence for the 18 m tram lining is as follows;

BOUT NUMBER	TRAMLINE OUTPUT
1	-
2	-
3	O/P 1
4	-
5	-
6	-
7	O/P 2
8	-
9	-
10	-
11	-
12	O/P 2
13	-
14	-
15	-
16	O/P 1
17	-
18	-

F.1.6

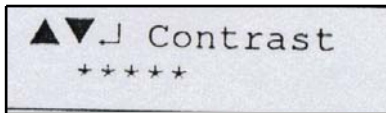

This is the contrast setting screen. *'s are shown as solid blocks and the CU and CD Keys are used to increase or decrease the contrast. Pressing the CR Key returns to F.1.

F.1.7



This is the screen for entering the Theoretical Speed Sensor factor manually. The first digit will flash and the CU and CD Keys can be used for cycling through from 0 to 9. With the desired number shown, the CR Key can be pressed to confirm and move to the next digit, which will then flash. When all four digits have been entered the new factor will be shown, pressing the CR Key then will return to screen F.1.

F.1.8

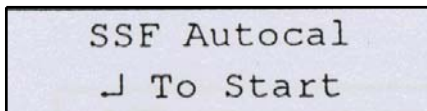

This is the first screen of the speed sensor auto cal procedure. When the drill is at the beginning of the 100 m mark, press the CR Key to start the procedure.

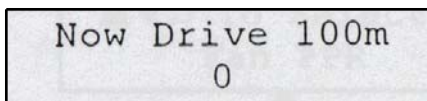

This screen now tells the operator to start driving towards his 100 m marker. The pulses received will be shown on the bottom line of the display.

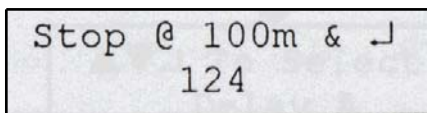

This screen is seen when 10 pulses have been received. The top line of the text changes to tell the operator to stop on the 100 m mark and then press the CR Key.

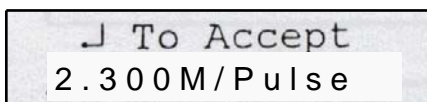

The newly calculated speed sensor factor is shown the bottom line of the display with the top line indicating to press the CR Key to except this new value. Once the CR Key has been pressed it will return to F.1, the newly calculated factor being substituted into F.1.6.

F.1.8

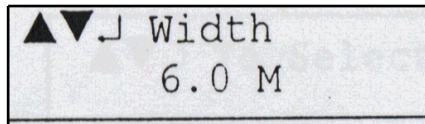

This is the screen for entering the working width of the drill. Using the CU and CD Keys the width can be increased or decreased in 0.1 m increments. Once the desired width is set the CR Key is pressed to confirm and return to F.1.

ALARMS/WARNINGS

All alarms are inhibited if the forward speed is below 2 km/h.

H.1

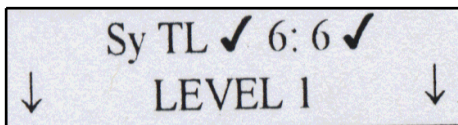

This screen is a variation of E.3. The tramline is retained but the button line shows that the hopper level 1 is low (I/P6). When I/P 6 is open, then the instrument will default to this screen, beep 5 times, the down arrows will also flash on and off. The alarm will reset when the I/P closes to 0 volts or it can be ignored by pressing the CL Key.

H.2

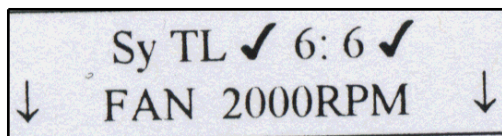

This screen shows the fan speed (I/P 2) is below the alarm level set. The instrument will default to this screen, beep 5 times and the down arrows will also flash on and off. The alarm will reset when the correct speed is obtained or it can be ignored by pressing the CL Key. The same screen and alarm conditions being used if the fan exceeds its maximum speed, although this time the down arrows will be replaced with up arrows.

H.3

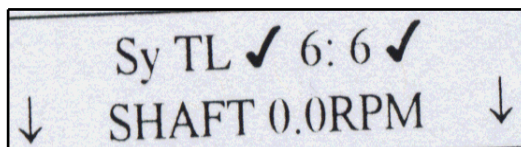

This screen shows that the shaft speed (I/P 8) is below the alarm level set. The instrument will default to this screen, beep 5 times and the down arrows will also flash on and off. The alarm will reset when the correct speed is obtained or it can be ignored by pressing the CL Key. Due to the slow rotational speed of this shaft the alarm condition only exists if there is no shaft speed input for 40 seconds.

H.4

LIFT
! DRILL FULLY !

This screen is shown if Key R4 is pressed in 'Manual' mode and I/P 11 is not closed to 0 volts.

H.5

DRILL MUST
! BE UNFOLDED !

This screen is shown if either Key L2 or R2 is pressed and I/P 9 is not closed to 0 volts.

H.6

LIFT
! MARKERS !

This screen is shown when Key R4 is pressed and I/P 5 is not closed to 0 volts.



SETTINGS

Sowing Rate Settings

1) Air Flow Regulator

- Unscrew the threaded wheel.
- move the threaded wheel along the dial to the appropriate setting.
- 5 settings are available depending on the type of seeds.

- Mark
- 1.
 - 2.
 3. Linseed, Rye grass, Rape, Lucern
 4. Wheat, Barley
 5. Peas, Field Beans

A good rule of thumb is to set the air flow, so the seed is delivered into the soil at a constant velocity. Care should be taken not to use too much air as this will prevent the seeds being blown out of the slot made by the disc coulter.

Settings

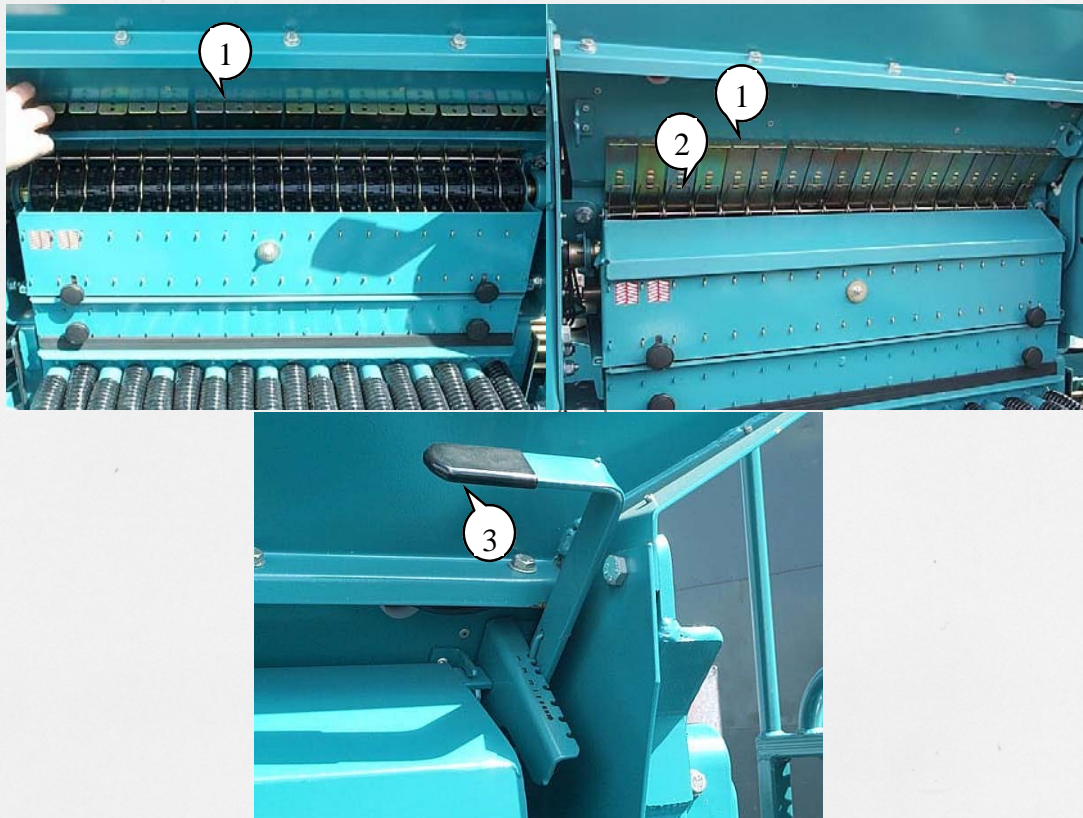

SETTINGS

* Distribution settings (please refer to Section 7 for settings)

2) Distribution shutter

* Raise or lower the shutter (1) according to recommendations. Insert the spring (2) into the appropriate catch.

* 3 opening positions are available for the shutter.

* Marker 0. Closed (when sowing one row in two, for instance).

1. Small seeds <8kg/ha.
2. Large seeds.

3) Base Flap

* Move the lever (3) slightly to the right and position at the appropriate marker.

* Marker 1. Cereal

2.

3.

4. Peas for canning

5. Peas

6. Beans

Max. Lower position, Hopper emptying

* The aim is to have the seeds metered out by the peg wheel with the base flaps open as little as possible (e.g. marker 1 for wheat and barley). However, if you notice constant projections of seed from the distribution system, position the lever one marker above the recommended setting (e.g. marker 2 for wheat and barley).

Settings

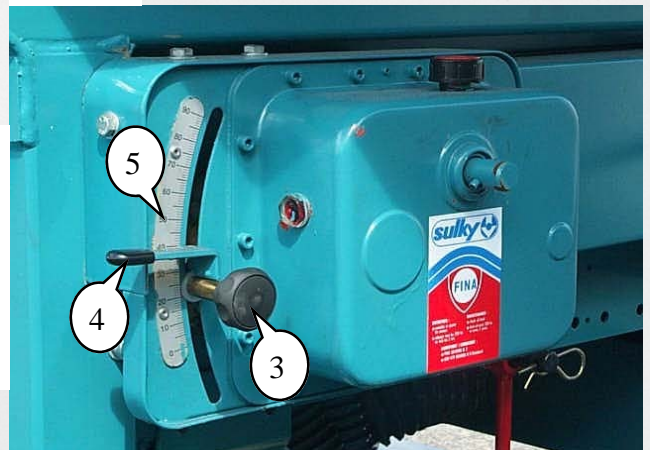
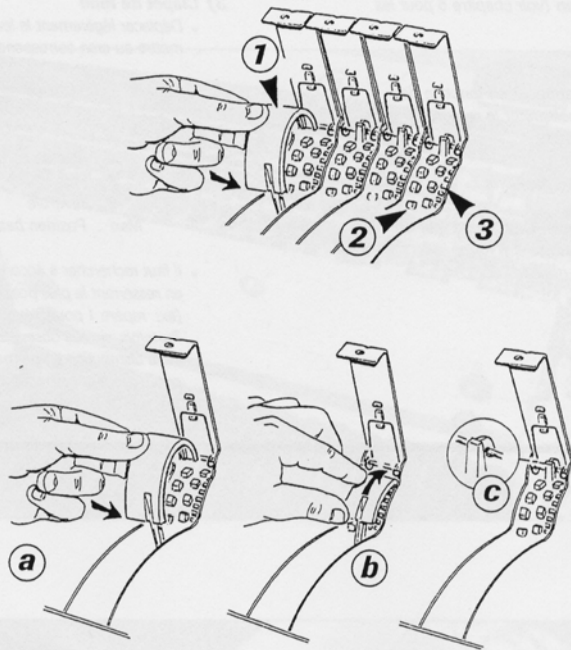

SETTINGS

4) Selecting the peg wheel

When fitting the rape shutter Ensure:

- The hopper is empty
- The shutters are in Position 2.
- The base flap is open to the maximum position.

- A. Engage the rape shutter wrapping it around the peg wheel.
- B. Pivot round
- C. Engage with the axle of the spring clip.
- D. Set the base flap back to position 1.

To remove reverse the procedure.

- Standard Seed Wheel. (2). (Large Seeds)
- Fine Seed Wheel. (Small Seeds < 8 Kg/Ha.

5) Variator

- * Using the knob (3) and the lever, position the marker according to the results of the calibration test (4)
- * Read the settings above the flat part (5)
- * Each marker change must be followed by a calibration test. For your information, 3 graduations on the adjustment scale equals a 10 kg/ha increase/decrease with cereal.
- * Scale range from 0 to 90.

Settings

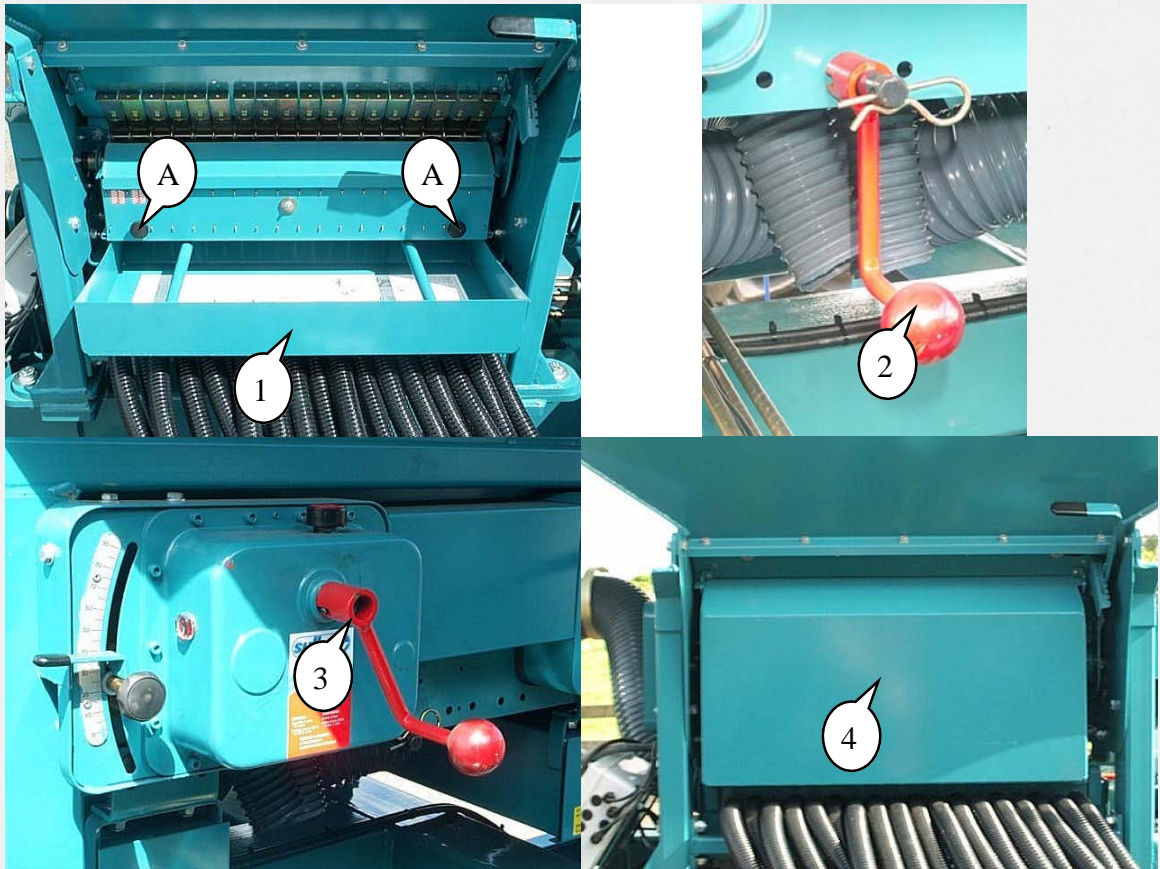

Very precise sowing requires a calibration test. Make sure your scales are accurate.

SETTINGS

B) Preparing the calibration test

* Use accurate scales and a container.

* Before carrying out the test, check that no-one is standing near the seed drill except the operator.

* Procedure

1. Release the two black plastic lock screws (A) above each venturi unit by turning anti-clockwise slightly until locks can be slid upwards, then retighten.
2. Push both venturi units forward to clear the air box inlets.
3. Position the calibration trays (1) underneath the feed rollers.
4. Fit the calibration handle (2) to the variator shaft (3).
5. Ensure the drill is not in tramline mode so that all the rollers turn.
6. Perform the calibration test according to the recommendations issued in the following pages.
7. Raise the trays back into the guard position.

Settings

1

Colza				
Rape	1	1	2	3
Raps				
Luzerne				
Lucern	1	1	1	3
Luzerne				
Ray grass				
Rye grass	1	1	1	3
Gras				
Blé				
Wheat	2	1	1	4
Weizen				
Orge				
Barley	2	1	1	4
Gerste				
Pois				
Peas	2	5	1	5
Erbsen				

5

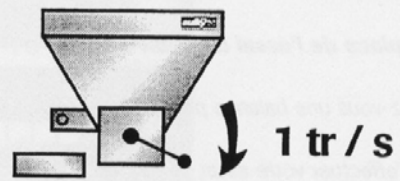

m	2,50	3,00	3,50	4,00	4,50	4,80	5,00	6,00	6,66
tr	60	50	43	37,5	33,3	31,25	30	25	22,5

6 - 7

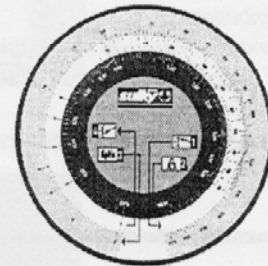

Kg (- or -)
x 40 = Kg / ha

2

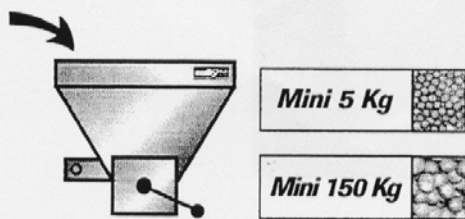

8

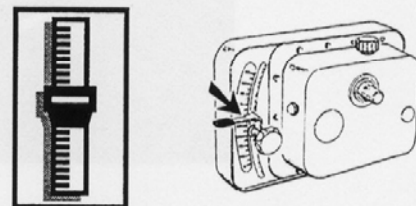

3

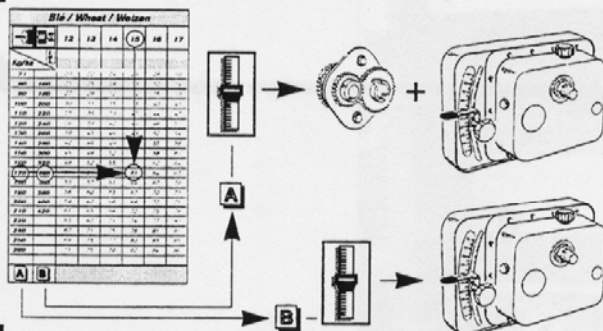

9

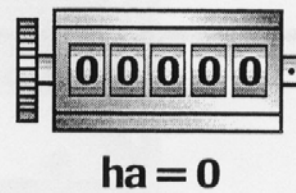

4

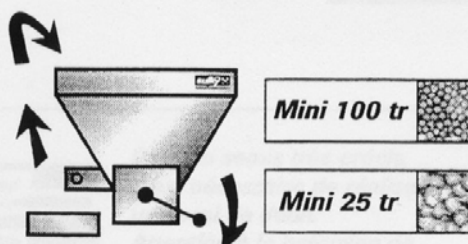

10

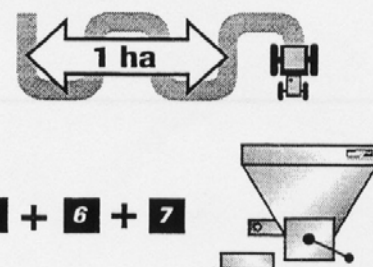

Settings

SETTINGS

C) Carrying out the calibration test

1) Static test

1 Set the distribution as described in the operator's manual (Shutters, base flap etc.)

2 Put the seeds in the hopper **on the day of sowing** (5 Kg of rape / 150 Kg of cereal) and carry out the following test.

3 **Set** the variator at the marker stated in the setting chart section at the back of the manual.

4 **Prime** the distribution manually: a **minimum of 25 turns** with the crank (the tray can be filled) if necessary, except for rape (minimum **100 turns**).

5 **Carry out** the test by completing a number of turns corresponding to the seed drill's width (turn steadily at **1 turn per second**).
The number of turns for a 4M drill is 37.5.
The number of turns for a 6M drill is 25.
(See table below)

6 Using accurate scales, **weigh** the quantity collected in both trays.

7 **Multiply by 40** to obtain the quantity per hectare or **use the calculator**. (see the following page)

8 **Correct** the variator setting (lower the lever completely, then raise it again to the required value).

9 **Reset** the hectare-meter after the calibration test.

10 **The most representative test is one carried out under real working conditions. After sowing a hectare check by carrying out another test. (proceed as above from Step 5).**

Drill Width (Metres)	Number of turns with the crank
4	37.5
6	25

Settings

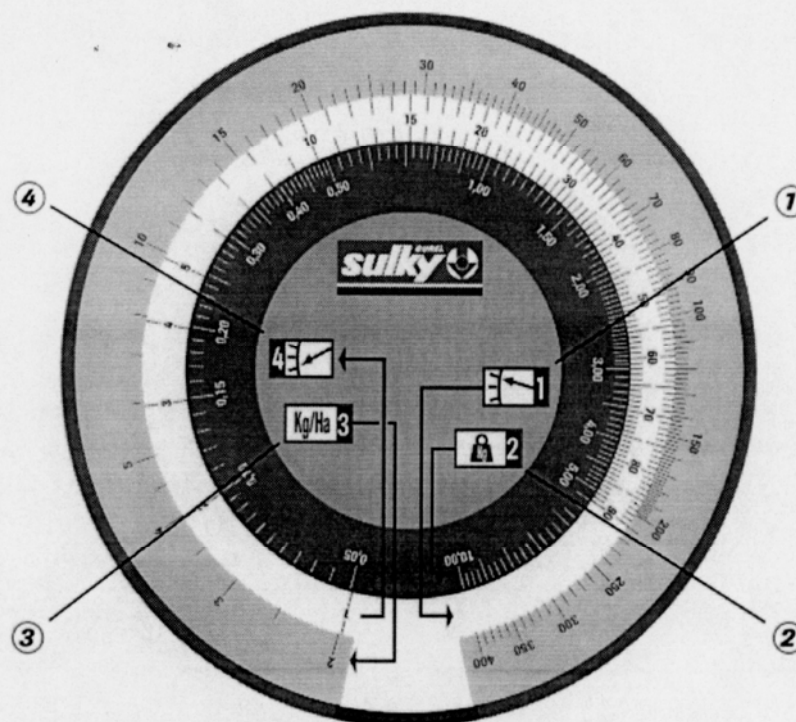

SETTINGS

2) Testing with the calculator

- * This calculator enables you to determine the new variator setting after carrying out your first calibration test.
- * Adjust the distribution settings and carry out a test according to the recommendations issued in the previous page.
- * Use:
 - Match line 1 (the variator marker setting used for your first calibration test) with line 2, which corresponds to the quantity (in kg) collected in the tray during the test.
 - Without moving the discs on the calculator, identify the required sowing rate setting on the kg/ha line 3.
 - Read the new recommended variator setting off line 4, according to your sowing and tillage conditions.
 - After sowing a hectare, carry out another check.
 - If you wish to change the sowing rate per hectare, using the same seeds, to sow another plot of land, you can use the calculator again to determine the new variator setting, working on the basis of the quantity you obtained for the first calibration test.

Settings



The hitching height and drawbar locking position affect the depth setting's choice. You may need to alter them to reach the required depth setting. (Please refer to the **HITCHING** section).

SOWING DEPTH

A Complete depth segment kit contains the segments shown below

Place the ram at its middle position
Use the drawbar ram to set the sowing depth (1) & (2).
Use the yellow graduated scale and depth segments (3) to precisely increase or reduce the sowing depth.

NOTE: 12.5mm depth steps on the ram can be obtained using different combinations of the depth segments

NOTE: Depth segments are not proportional to machine seeding depth.



1/2" 1" 1" 1 1/2" 2" 4"

Settings - Memory Cylinder

If the drill is fitted with the Moore Expert Drill Control Unit, the Memory Cylinder can be used to set the sowing depth with out the use of depth segments.

NOTE: To Set the memory cylinder always use the following sequence; (See Pages 37 to 39)

- 1) Retract the Internal Stop of the Memory Cylinder fully using Key L4.
- 2) Retract the drawbar fully using Key L3
- 3) Select L4 again and extend the ram until you reach the required depth. To change the drill depth whilst drilling use Key L4 in manual mode.

A Section through the Drawbar Ram showing the oil in each section during operation

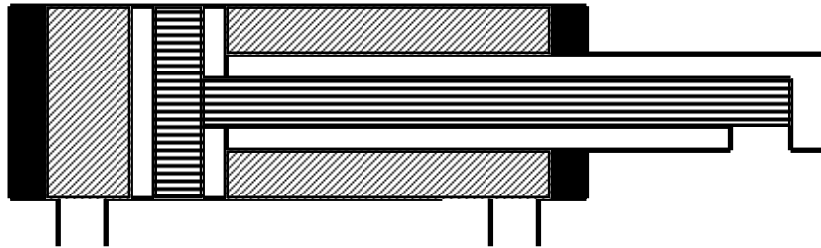

1. Retracting the internal stop to zero the memory cylinder

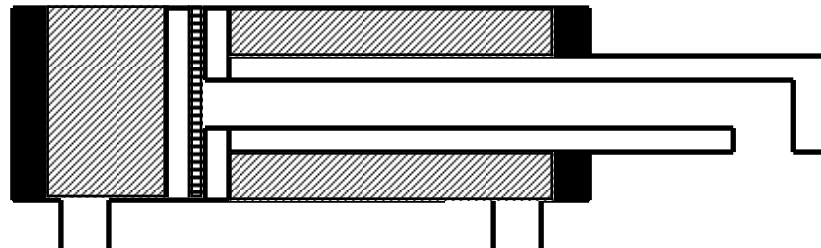

2. Retracting the drawbar fully

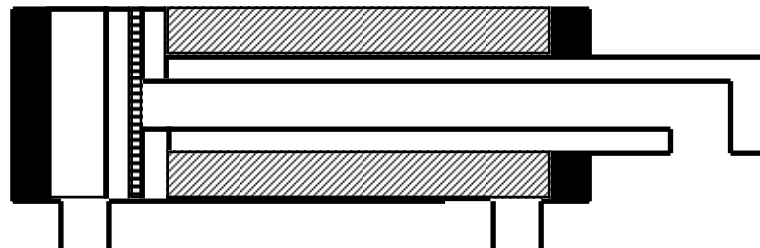

3. Setting the required working depth

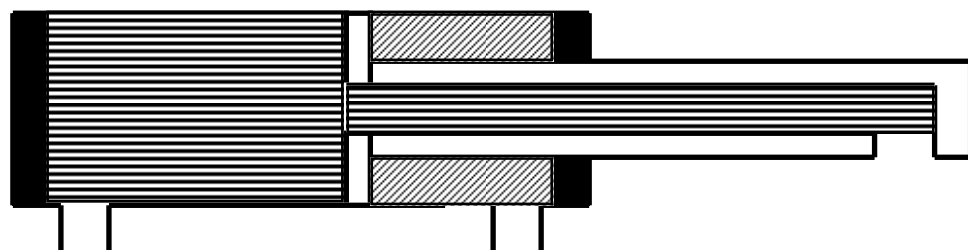

Settings

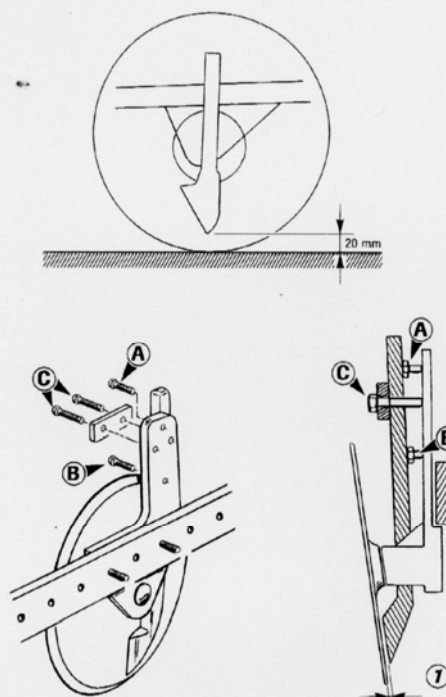

Set the coulters with the machine resting on the ground.

SETTINGS

A) Height setting:

The coulters tip must be set approximately 20 mm back from the tip of the disc.

- It is imperative that the minimum distance is complied with to protect the coulters from shock damage
- This measurement can be finely adjusted by placing a wooden block beneath the coulters with the machine resting on a flat surface.

NOTE: When using the seed drill on very loose or trashy soil, it is recommended that you raise the coulters approx. 40 mm above the disc, to improve its motivity.

B) Tilt setting adjustment:

The coulters' cutting edge (1) must be:

- Parallel to the disc.
- As close to the disc as possible, without limiting its rotation.

If the disc does eventually block, the coulters settings must be adjusted.

By adjusting the tightness of screws A and B, one can either increase or reduce the distance between the coulters and the disc. Make sure that the coulters' cutting edge always remains parallel to the disc.

- Use the screws (C) to lock the coulters

Settings



SETTINGS

Side Markers

- Setting the markers in their working position

When the markers are in their folded position, the second marker arm is free swinging and is supported by a rubber stop **(1)**.

The markers are factory set

However if you wish to alter this setting, move the disc support **(3)** along the box section.

The angle of the second marker arm can be adjusted using the wire rope tensioner **(2)**

It is also possible to change the angle of the Disc Hub Assembly **(4)** to increase or decrease the mark for the next bout. This will depend on whether the seedbed has been prepared or drilling direct.

The distance from the final sowing line to the disc equals half the working width plus half the spacing.

Settings

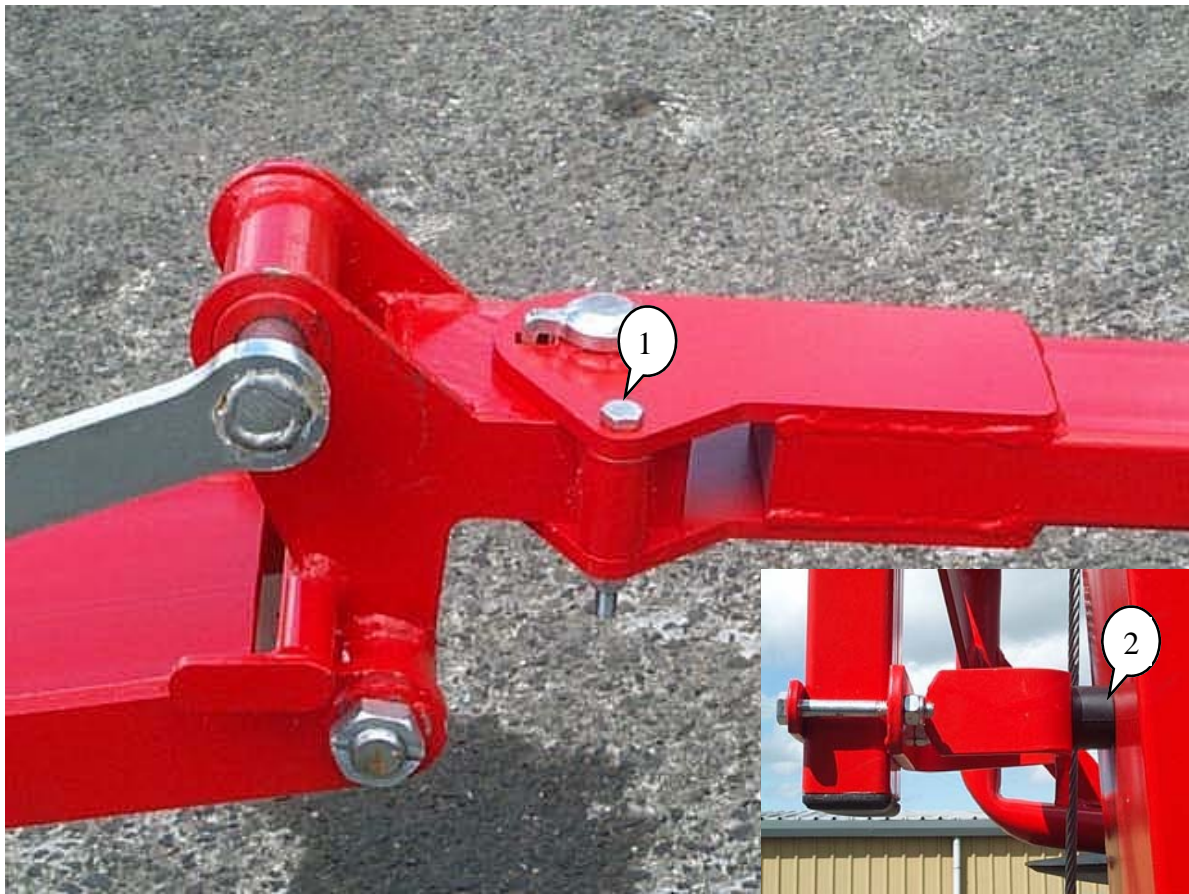

SETTINGS

Safety

The marker safety devices only operate in the working position

Passive safety M10 X 100 Class 8.8 shear bolt. **(1)**.

Transport safety Rubber support between marker arms one and two. **(2)**.

Settings

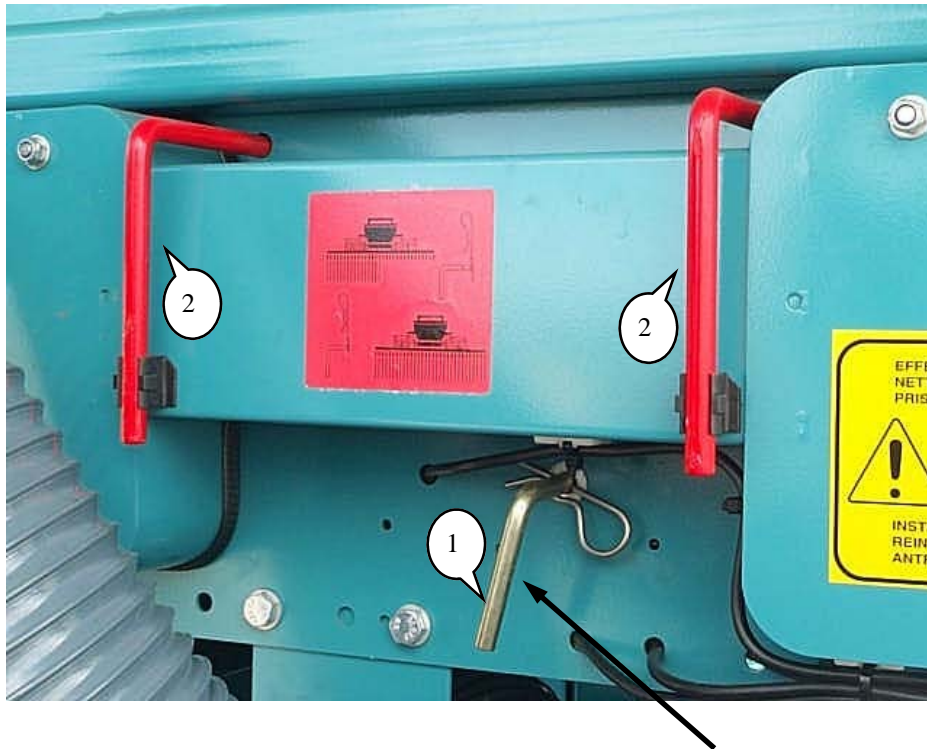

Headland Splitter Gearbox
Part No: A207HSG



SETTINGS

Disengaging half the seed drill.

The left hand side of the drill (whilst facing forward in the tractor seat) can be shut off for drilling around the perimeter of the field and beginning the correct tramlining sequence. The procedure is as follows:

- Pull the zinc plated handle (1).
- Remove the R clip and place it in the second hole which is uncovered.

Emptying the Hopper.

The hopper can be easily emptied and cleaned out, by pulling the two red levers (2) which will empty the hopper via two tubes. This is best done when the machine is folded and fully lowered on the ground.

A. FIELD OPERATION

Do not turn sharp corners with the Uni-Drill especially in direct drilling operations as this will give wrong disc to soil side thrust. When this happens the disc is parted from the seed coulter and trash can then enter between them resulting in blockage to the seed flow. It is better to lift the machine out of and into work when turning corners.

B. WORK RATE

As there is no disc bounce due to the high inertia coulter system with press wheels, relatively high ground speeds can be tolerated giving high work rates. (11 - 15 Km/hr) The operating speed and the quality of work which results is controlled by field conditions but where ever possible a steady speed should be maintained. As field conditions vary, it may be necessary to adjust the coulter settings to maintain seed depth cover.

C. DRILLING IN A CONVENTIONAL SEEDBED

When working in cultivated soil, most of the drill weight is carried on the press wheel Rollers and tractor drawbar. Seed depth can be obtained by Extending or retracting the depth control ram. The soil is usually tracked to the depth required by the disc seeding units and consolidated by the press wheel rollers - this gives excellent soil seed contact equalling ideal conditions for seed germination.

It is recommended that the centre of the field should be drilled first and the headlands last. If the headlands are planted first then the tractor and drill will travel and turn on planted ground, thus disturbing, compacting and moving seeds that have been placed at a constant depth. Check the seeding depth in the field and on headlands, remember the headlands tend to be more consolidated than the remainder of the field. If headlands are drilled last the field is left tidier on completion

On rougher types of seedbed the drill itself tends to be self levelling. The seed tube and disc coulter units tend to move the soil from humps to hollows. **IT IS NOT NECESSARY TO HARROW AFTER SOWING.** Harrowing will move seeds either shallower or deeper thus giving uneven germination. Remember seeds that are planted two to three inches deep take about two weeks longer to germinate and appear as weak plants, that are under stress and are susceptible to disease and slugs

If rolling behind the drill on lighter soils is thought to be beneficial, remember that the seed has been accurately placed at the ideal depth for early and even emergence. Rolling will tend to flatten the ridge of soil between each press wheel mark and will in fact add to the soil cover over the seed thus slowing emergence and probably reducing vigour. This extra soil cover over the seed must be allowed for, when deciding drilling depth when starting the field.

Operation

D. DRILLING IN WET CONDITIONS

The Uni-Drill is fitted with adjustable scrapers for the press wheels. Wet Soil will usually build up to about one inch on any wheel. Adjust the scraper so as to knock off the excess soil that would build up over the normal amount of soil that sticks to the press wheels. Leave a gap of 15 to 20 mm between the scraper and the press wheel. Never reverse the drill with the seed tube coulters in the ground as this would block the seed outlets with soil. Where there are very wet pockets of soil in some fields, the road wheels can be used to slightly raise the drill out of the ground thus assisting the drill to drill high; always keep the drive wheel in contact with the ground. Speed is the biggest aspect, below 7 km/hr the disc coulters will tend to block, above 9 km/hr is the optimum for drilling

E. DRILLING INTO STRAW INCORPORATED SOIL AND TRASHY CONDITIONS

In heavy trash conditions it may be necessary to raise the tip of the seed tube coulters so that the disc will cut through the trash before the coulters open the slit. In heavy maize trash, especially in the direct drill or no-till situation, it may be necessary to raise the tip of the seed tube coulters 30 to 40 mm above the edge of the disc. The discs cut through the trash very positively. The weight of the press wheels keep the discs anchored and do not allow the discs to ride out of the soil, even when there is a lot of trash present. Bulldozing normally occurs when a disc meets trash, tries to ride up over the trash, then pushes it in front of the disc, thus causing bulldozing and blockages. If this happens it is usually due to the soil underneath being too loose. The drill will cut cleanly through, given that it has something to "bite on". Consolidating the field with either rollers or a land packer, sufficient to allow the drill's discs to turn, will usually cure the problem. A Speed of 9 - 11 km/hr works. 7 - 8 km/hr doesn't.

The trash itself, on decaying, produces acids, toxins, etc., which tend to damage or kill the germinating seed. If the trash is mixed with the soil and consolidated tightly to give a good straw/soil contact then the soil will absorb the toxins as they are formed, before they can harm the germinating seedlings. The press wheels on the UNIDRILL consolidated the trash, soil and seed in exactly the right manner to give very healthy plant stands even in the heaviest incorporated residues. If straw is incorporated into the soil to leave a loose fluffy seedbed then it is better to consolidate this first using either a roller or land packer, etc., before drilling.

F. MINIMUM TILLAGE AND DIRECT DRILLING

In certain soils, especially if they contain stone or brash, it is recommended that the top 1" or 2" should be cultivated or scratch tilled. This will encourage the germination of volunteer cereals and weed seeds. It will also help to level out the tramline and wheeled tracks. Also if stones are left undisturbed in the top layer, they become embedded and the disc will ride from stone to stone without getting good penetration.

In soft field conditions it is essential to set the discs deep enough to cut through all the mat or surface trash. Seed will germinate and grow better when in contact with the soil. In wet, soft conditions the disc may be set to penetrate deeper than required. As the drill moves forward the seed is trapped by the sides of the slit and do not necessarily fall to the bottom of the slit.

Operation

G. DIRECT DRILLING GRASS PASTURES.

Four methods are suggested for direct reseeding grass into grass pastures.

- A. If the pasture has been badly poached or there are bare patches due to frost kill etc., over the winter, about 110 Kg/Hectare of a vigorous growing type of grass (e.g. Italian Rye Grass) should be drilled just before growth starts (March / April).
- B. Where a first cut or second cut of silage is being taken, cut low to the ground and direct drill the new grass mixture the next day. There should be enough moisture retained in the soil to germinate the seed and get it growing before the cut sward can fully recover.
- C. Graze the pasture as bare as possible, then spray Gramoxone (1.4 Litres/Hectare) and direct drill the new seed mixture. The Gramoxone used at a low rate will not kill all the old grass sward but should retard its growth sufficiently to get the new seeds established.
- D. Where the old pasture is very weedy and a complete reseed is required, spray with Roundup to get a total kill of vegetation. Leave the field for the recommended period and direct drill with the new seed mixture. To get a better grass cover, cross drilling at an angle (30 - 45) degrees is recommended, especially with the wider row spacing UNIDRILLS. Check the reseeds for Leather Jacket, slug or fruit fly damage and treat accordingly. Grass sown after 1st August should be sprayed with pre-emergence with Dursban or Spannit to protect from fruit fly and leather jackets. Slug pellets should be used as required.

H. PREVENTING SOIL COMPACTION

1. **Whenever possible, use low-pressure tyres on all machines operated in fields in order to reduce superficial compaction**

Mounting wide tyres or dual wheels is not enough, the tyre pressure must be adjusted accordingly. Aim for 0.6 Bar, according to the tyre manufacturer's recommendations. As the UNIDRILL is a towed seed drill, it exerts no weight on the rear tractor wheels and does not require counterweights to be mounted at the front.

2. **Reduce the load per axle to avoid in-depth soil compaction.**

Avoid loads over 6 tons per axle, if heavier trailers must be used, park them at the field entrance. Prefer lightweight trailers, as the UNIDRILL requires little tractor power, moderately powerful - and therefore light weight - tractors are sufficient.

3. **Till on dried-out ground.**

Be patient and wait for the right time of year before starting tillage. According to scientists as soon as drying soil changes colour, it acquires resistance to compaction. After 4 or 5 years of conservation tillage, the ground drains water faster and becomes more resilient, which reduces the necessary waiting time. More Humus in the soil increases its ability to carry weight without compacting.

4. **Provide calcium and magnesium to compensate the grounds eventual acidity.**

Aim to maintain a PH of 6.5 - 7 to ensure optimal stability of the clay-humus compound.

5. **Enrich the soil with organic matters to preserve it from compaction and to increase its resilience.**

Leave straw and culture residues on the ground, spread manure, grow fodder plants and avoid powerharrowing

1. BURYING THE STRAW

1. **Select a suitable variety.**

According to the selected variety, the quality of produced straw can vary as well as its shock resistance. A variety that is resistant to illness and does not imperatively require fungicidal protection at the end of the season will also be more easily decomposed by the fauna in the soil. A late spray of round up is recommended

2. **Prepare and adjust settings on the combine harvester**

Tightening the thresher and increasing the rotational speed will help to break the straw and help to spread it better. Dry straw breaks more easily under these conditions, harvest the fields that you wish to sow first. The combine harvester must be imperatively equipped with a chaff spreader. Shred the straw into chaff of 5-6cm (sharpen the shredder blades, tighten all belts) and spread evenly.

3. **Shred the chaff and stubble behind the combine harvester**

In particular if the catch-up period is short, the cutting level is high, the chaff is poorly spread out and you wish to till the soil with tools fitted with tines. Don't drill into poorly spread chaff.

4. **As soon as the sowing is finished, keep clean and strong crops growing together.**

Use clean seeds that are free of weeds and have a high germinal power. The seeds must be placed to obtain a fast and even growth, to create a culture that will be able to compete with weeds and have a high germinal power.

5. **Use a seed drill which causes little disturbance of the soil such as the UNIDRILL.**

The UNIDRILL works exclusively in the sowing line, which avoids seeds that escaped the stale seed bed from emerging. Prefer wide spacing between rows such as that of the UNIDRILL (16.6 cm).

6. **Watch for the evolution of the flora during the cultures' growth period**

With conservation tillage, the usual weeds do not appear in the same quantities or at the same dates: additionally, new species may appear. Prepare for this evolution by improving your botanical knowledge. Every week while the crops are growing, walk through the fields moving into plots of land in a continuous series of "Ws", identifying plants and their respective development, write any observations down and trace the history of each plot of land.

7. **Use herbicides of new chemical categories every year to avoid resistance.**

8. **Clean borders, fallows and crops before the heading**

Cut or shred weeds on embankments, in ditches and in fallows rather than treating them with total herbicide, some perennial plants might not react to the product and may then become difficult to get rid of. Some find it preferable to grow rye-grass on boarders. It chokes weeds and can be easily kept under control using a mower. During the season destroy the remaining localised weed growth spots using localised treatments, using a strimmer or by hand.

9. **Avoid scattering weed seeds when harvesting.**

Start harvesting the cleanest plots of land. In weed-infested plots, harvest the cleanest parts first. Clean the combine harvester well after harvesting weed-infested land.

Ploughing is a last resort if the above techniques are not sufficient enough to get rid of annual grass or dicotyledons.

J. OTHER SUGGESTIONS

(i) Pre– Emergence Marking. (If no pre-emergence marker is fitted)

Once the operator is used to the hydraulic system operating the transport wheels, the wheels can be adjusted to just make a mark on the soil behind the drill. This can be easily followed for pre-emergence chemical applications. This is achieved by activating the float position on the spool valve whilst on the tramline bout.

(ii) Pre loading Dragarms

If it is noticed that during drilling, the coulters behind the tractor wheels are not drilling at the same depth as the rest, the dragarms on these coulters can be preloaded by placing washers or similar spacers between the front spring - lower and the spring locating bush.

1. Before all maintenance, service or repairs and when trying to identify a breakdown or malfunction you must ensure that the power drive is disconnected and that the engine is switched off and the ignition key removed.
2. Check Tightness of screws and nuts. Retighten if necessary. (especially the transport wheels)
3. Before working on a machine in the raised position, support it by appropriate means.
4. Before replacing a working part, wear protective gloves and only use the appropriate tools.
5. To protect the environment, it is forbidden to throw or pour out oils, grease and filters of any description. They should be given to firms specialising in their disposal.
6. Before working on any electrical circuit disconnect the Power source.
7. Protective covers which are prone to wear should be checked regularly. Replace immediately if damaged.
8. Spare parts must conform to the manufactures specification. Only use genuine Moore parts.
9. Before undertaking any electrical work on the tractor or attached machine disconnect the alternator cable and the battery.
10. Repairs carried out on parts under tension or pressure (springs or components under pressure etc) require specialist knowledge and tooling so should only be carried out by qualified personnel.
11. In the winter time leave the base flap fully open so any rodents can escape otherwise they will chew through a peg wheel to get out.
12. Do not leave any seed in the machine after the drilling season is finished

Maintenance

Cleaning machine (Seedhopper)

External

Avoid high-pressure water directly at moving parts and electrical components. It is advised to avoid getting water into the airboxes and metering units.

Internal

Slide the venturi units out of the way and place seed trays under the peg wheels (as calibration), drop the seed flaps out of the way by moving lever past position 6 on scale. This will allow any grain left in the tank free passage past the peg wheels. The inside of the hopper/metering units and air boxes should be cleaned out regularly with high pressure air **NOT** water. To clean air boxes remove end caps and blow through.

- These should be kept open during the winter to help prevent damage from rodents.

Lubrication

The servicing periods given are considered suitable for average working conditions in normal working hours and must be adjusted to suit abnormal conditions. Regular servicing is essential to the performance of the machine.

Daily Servicing

- Check for any oil leaks from hydraulic rams and any damaged pipes.
- Check all guards and safety related components.
- Check wheelnuts.
- Check the tightness of the discs and press wheels
- Lubricate the tramline clutch springs by spraying with penetrating oil.

Grease Drawbar Cylinder Pivots (3)

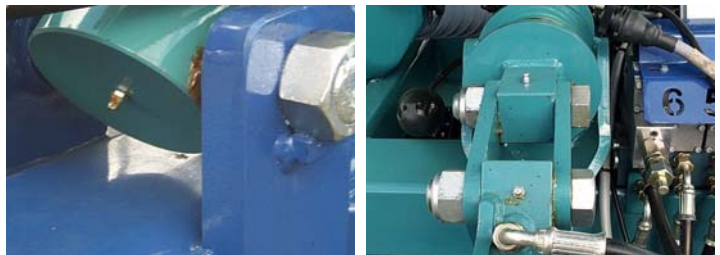

Drawbar Pivot bottom

Drawbar Pivot Top

Grease Drawbar pivots (2)



Left Drawbar Pivot

Right Drawbar Pivot

Grease all Grease Nipples using standard Agricultural grease.

Maintenance

Grease Marker Ram Pivot

(2)



Left Marker Ram Pivot Right Marker Ram Pivot

Grease Wing Pivots

(4)



Left Front Wing Pivot Right Front Wing Pivot

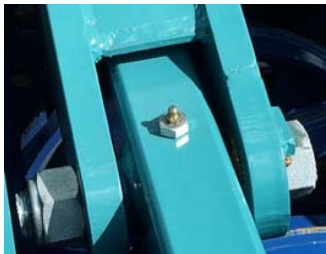

Left Rear Wing Pivot Right Rear Wing Pivot

Grease Wingram cylinder ends.

(2)



Left Wing ram Pivot Right Wing Ram Pivot

Weekly servicing

Drive Chains - Grease and check tension.

Variator - Check oil level, top up if necessary with ATF DEXTRON 11 or equivalent

Post Seasonal Maintenance

Drive chains - Remove and soak in oil bath.

Moving parts - Oil all moving parts.

Nuts/Bolts - Coat exposed threads with grease.

Overall - Cleaning machine, remove any traces of seed from the metering and delivery system, especially the airboxes. Half an hour now will save a lot of trouble next season removing chitted seeds from the airbox

Replace oil in the variator.

Note: Replacement control panels are expensive!!

If possible remove the RDS control panel from the tractor and place it in a warm dry room, away from possible damage whilst out of use.

Maintenance

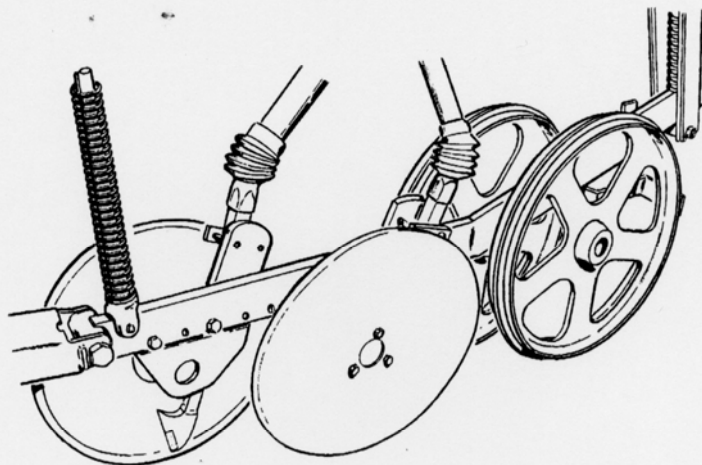

**Change the oil every 500 ha or every 2 years at the most.
Never grease the metering devices or the coulter tubes.**

Maintenance

A) Cleaning

- * Clean the inside of the hopper and metering system.
- * Clean the seed drill.
- * High-pressure cleaners are liable to cause damage to bearings and electrical circuits!

B) Greasing

- * Grease the machine regularly at the beginning and end of the season.
- * Grease the markers every 20 hours.
- * Lubricate the tramlining clutch springs (by spraying with penetrating oil).
- * Lubricate the drive chains.
- * Grease the hectare-meter pinions with a knob of grease.
- * Check the oil level in the variator (with the seed drill horizontal), and top up the red dot with ATFDEXTRON II D automatic gearbox oil.
- * **Change the oil every 500 ha or every 2 years.**

Maintenance

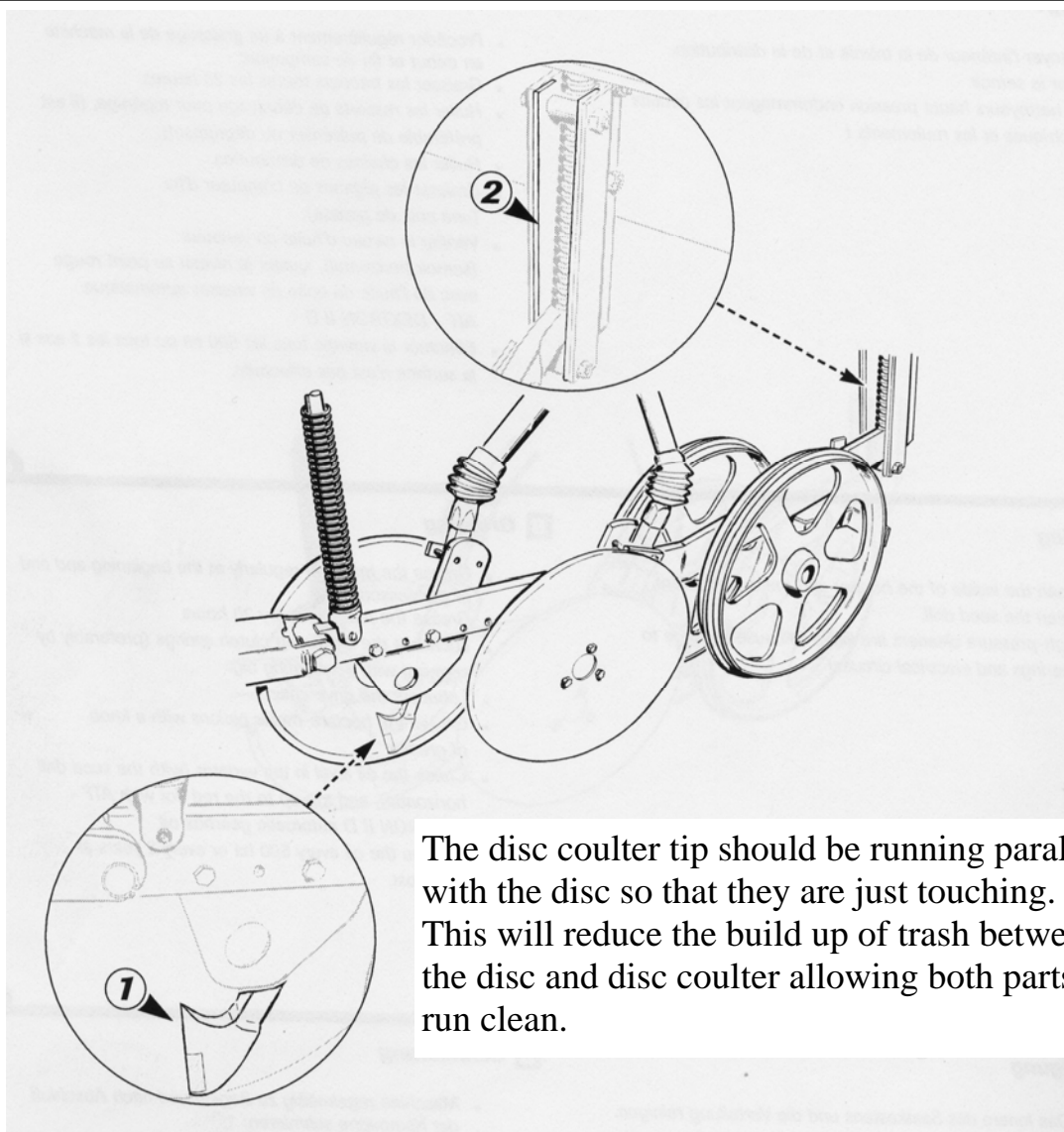

The disc coulters tip should be running parallel with the disc so that they are just touching. This will reduce the build up of trash between the disc and disc coulters allowing both parts to run clean.

Maintenance

C) Checks

Check the following signs of wear

Coulters (1)

These are essential parts of the sowing device and must imperatively have an aggressive shape. "Charge weld" them before excessive wear Occurs.

Rear guiding plates (2) of the drag arms. (ref: 213-1234)

Never lubricate or grease these parts
Mount the guiding plates upside down or change them if they become too thin.

Check the tightness of the following parts:

- After 20 hours of use:
Check the tightness of the main bolts.

Carry out these checks regularly, particularly when using the seed drill on hard or rocky soil.

- After 10 hours of use:

Check the tightness of the disc mounting bolts (disc fastening screws) and the tapered hub bearings.

If these bearings grow loose they must be tightened.

- Remove the bearing's dust cap.

- Tighten the bolt until the disc's rotation becomes difficult.

- Loosen the bolt a quarter of a turn. Always use Loctite.

Regularly check the tightness of the wheels and the tyre pressure.

Tyres: 500/50 - 17 = 2.5 Bar
 550/45 - 22.5 = 1.5 Bar

Tyre pressure chart for 500/50 - 17 Nokian Tyres

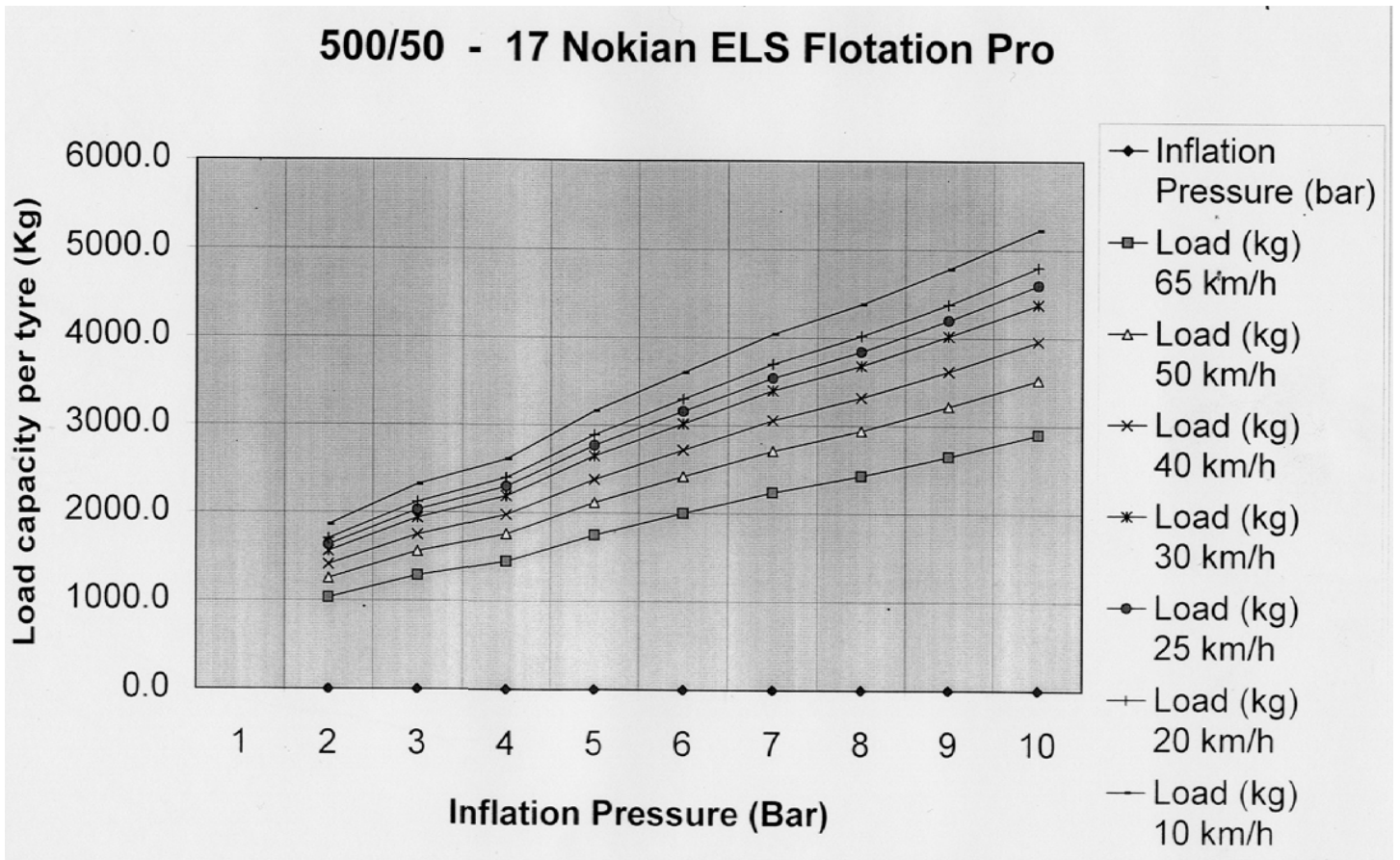

Tyre pressure chart for 550/45 - 22.5 Flotation Pro Radial Vredestein Tyres

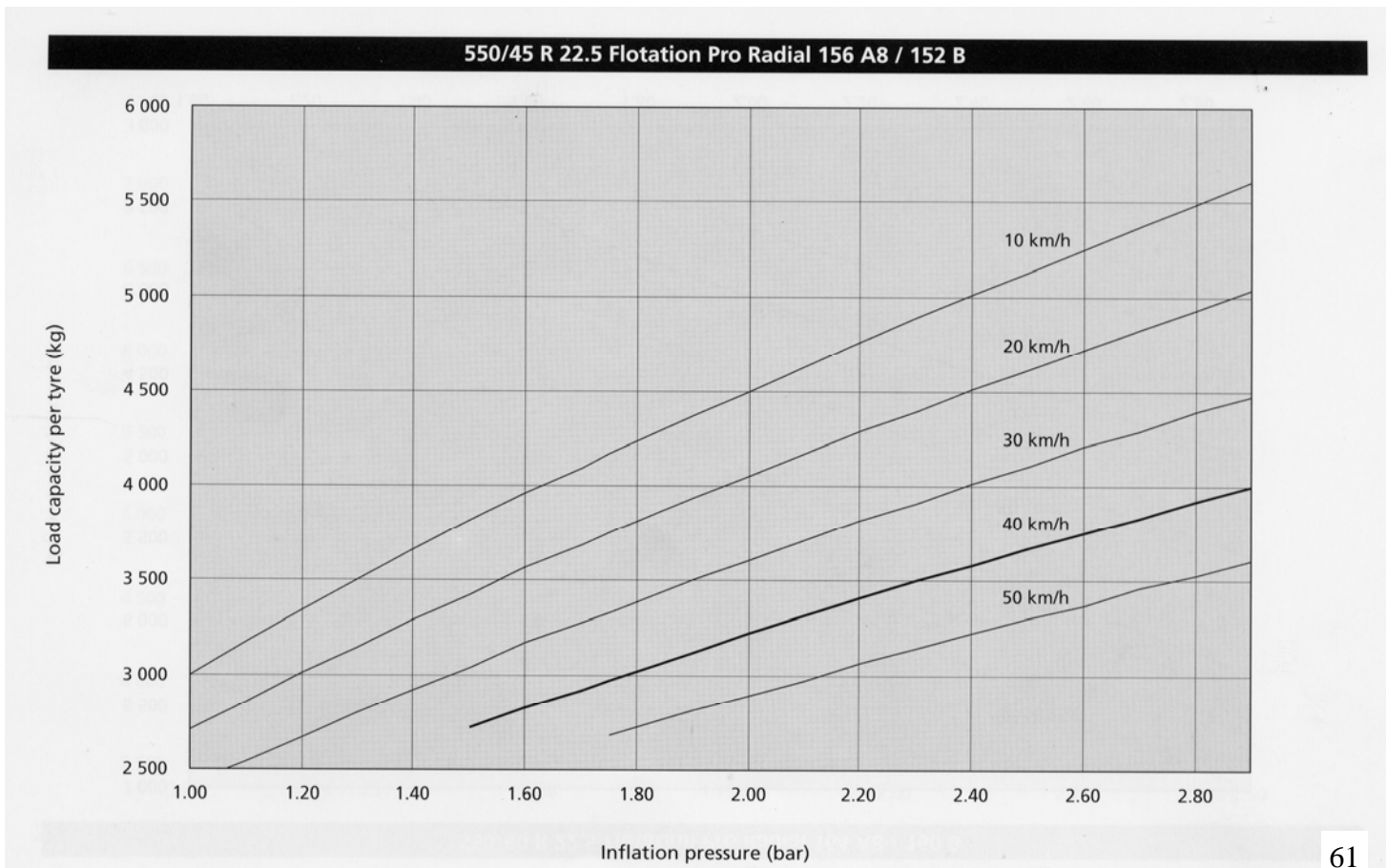

MS Flow Modulation

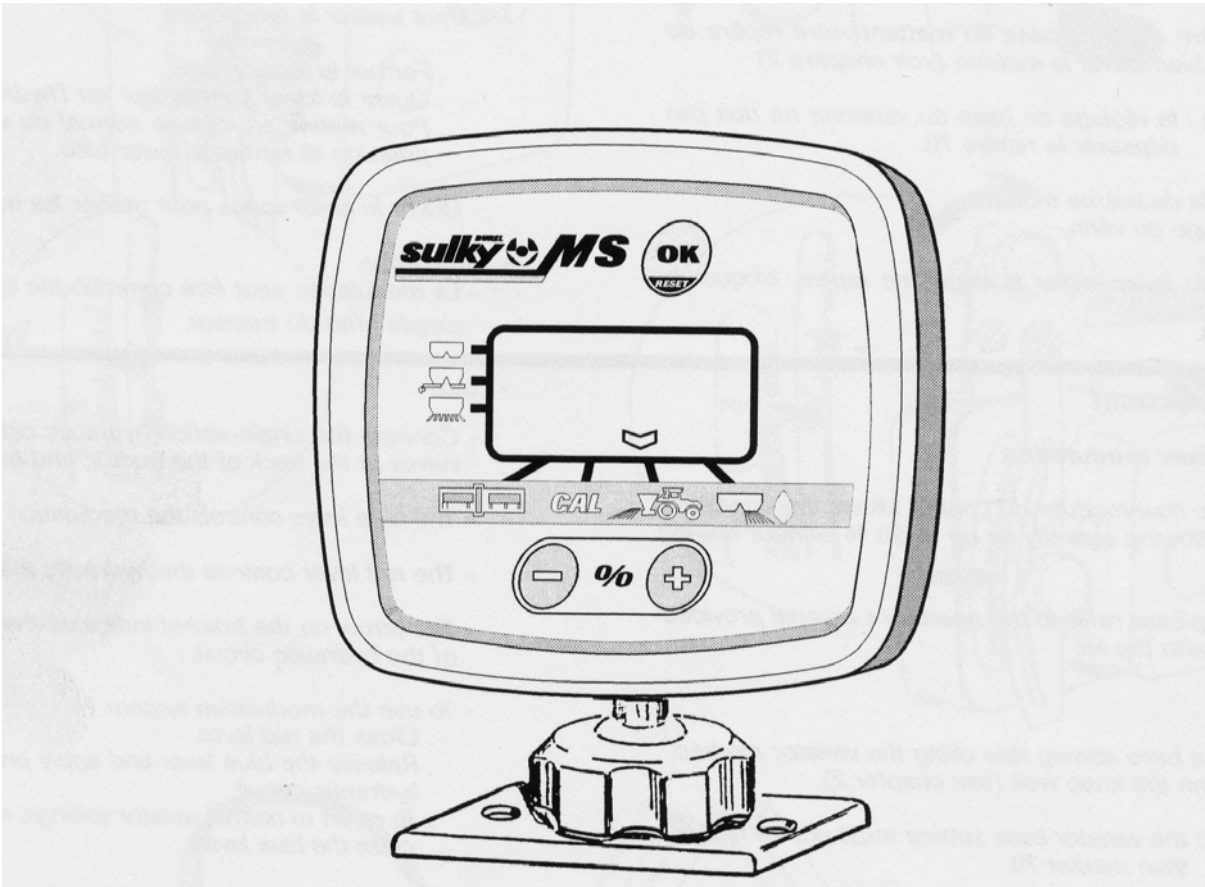

Starting up

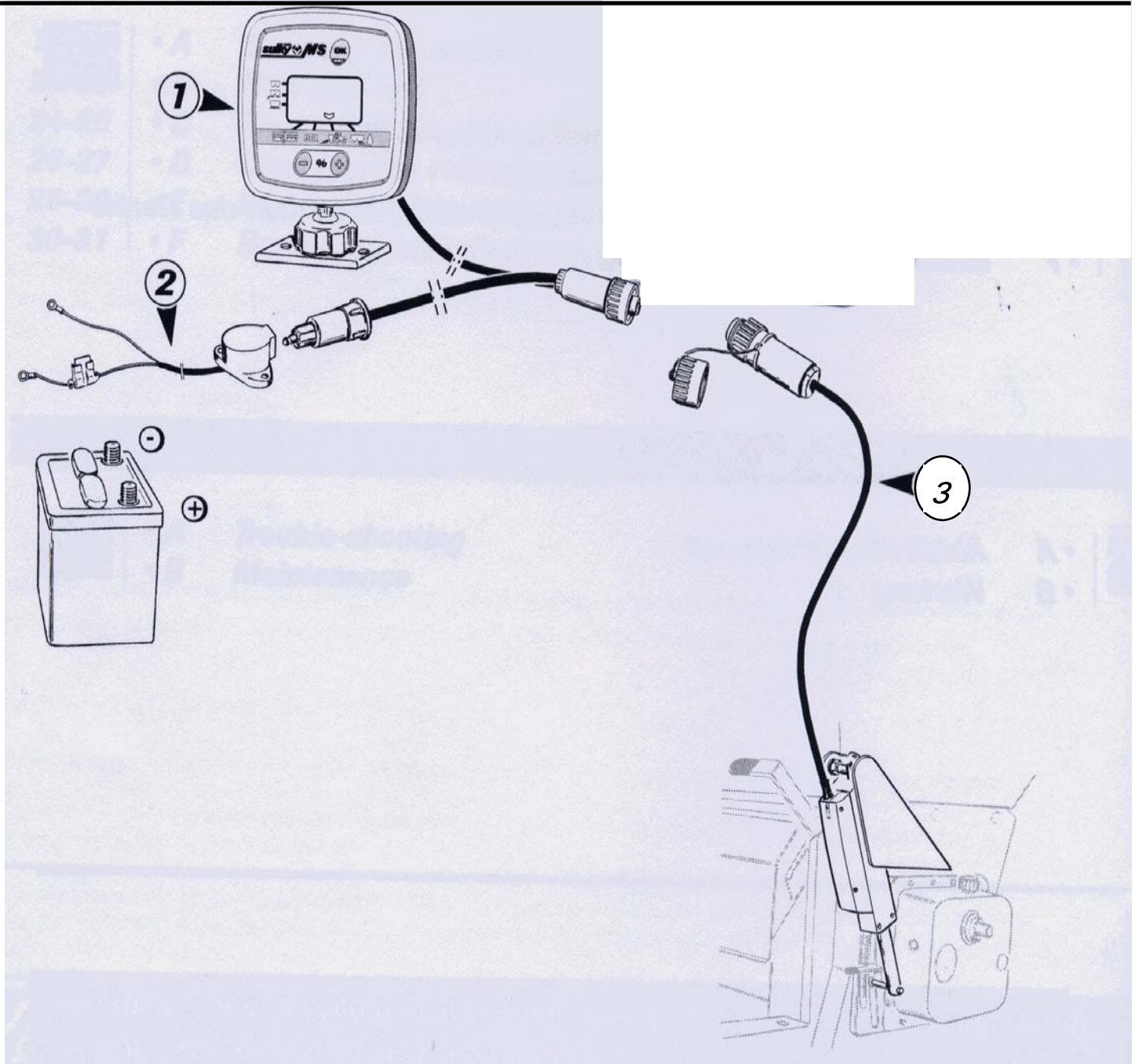

System function icons

Connection:

1. MS unit.
2. Power supply circuit with 7.5 Amp fuse.
3. Sower Ram Bundle.

Power Connection

Connection:

It is mandatory to connect the Unit directly to the 12 Volt battery with the connection cable provided. The unit should be lit up when the connection is made. The unit is fitted with a buffer battery to preserve data.

Starting up

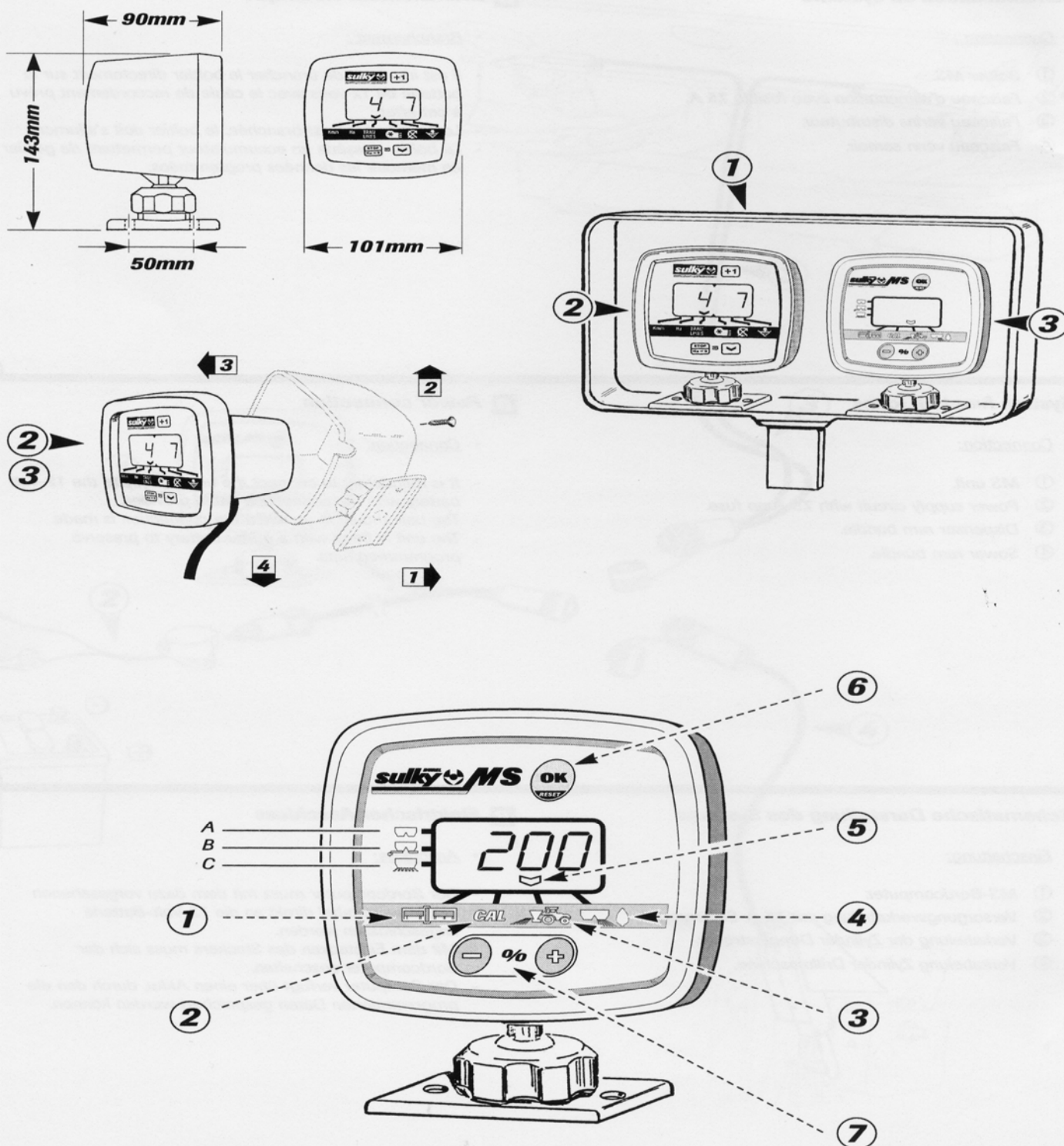

C Mounting the unit

- **Positioning:**
 - The electronic unit should be positioned in such a way as to be accessible and visible to the driver.
- **Fixing:**
 - Four fixing positions in relation to the panel are available by removing the unit casing.
 - Fix the unit bracket by drilling at the chosen spot (2 holes, distance between axes = 50 mm, Ø 5 mm)
 - With sowers fitted with a Tramlines or Tronic unit, use the special MS bracket.

D Functions

- **Choosing the machine:**
 - A - DPX - GLX
 - B - DPA-XL
 - C - Sower
- ① Opening indicator.
- ② Calibration (flow rate tests).
- ③ Adjusting flow rate while working.
- ④ Border spreading.
- ⑤ Cursor.
- ⑥ Recording.
- ⑦ Changing calibration and flow rate values.

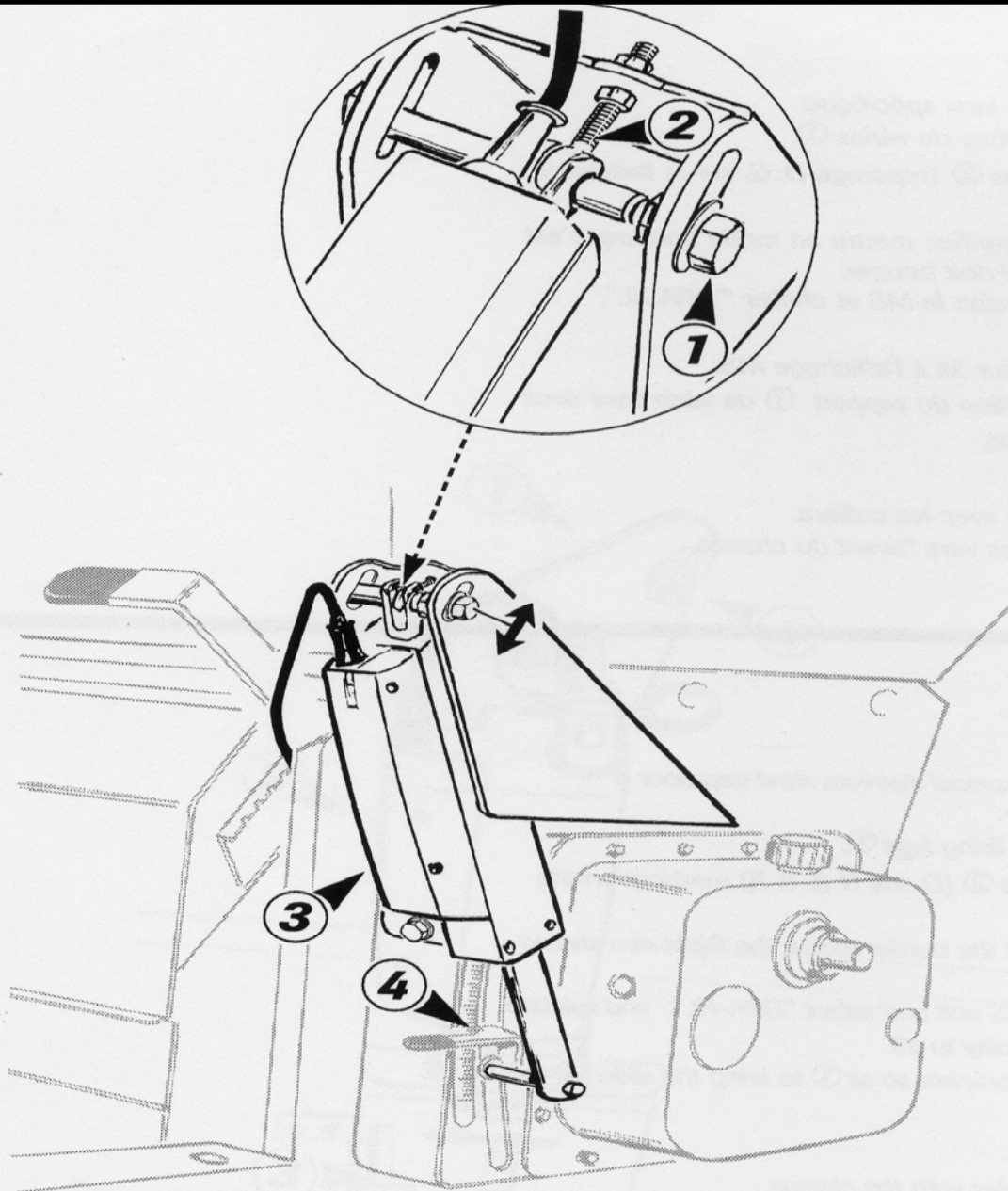

3) **SOWERS:**

- Mount the ram bracket on the upper left corner of the variator.
- Mount the ram fixing lug (Screw H10 ① + Nut + threaded adjustment rod ②), and the ram ③.
- Mount the ram ③ on the machine.
- Energize the MS unit and select "Sower"; then validate.
- Set the MS display on the 35 ④ mark.
- Move the ram bracket so that the slider comes to 35 (adjust with the threaded rod ②).
- Tighten the screw H10 ① and the nuts on the threaded adjustment rod ②.
- Secure the cables with the clamps.

Note: Without the ram bracket, there is a knurled screw for manual variator operation.

Operation

1

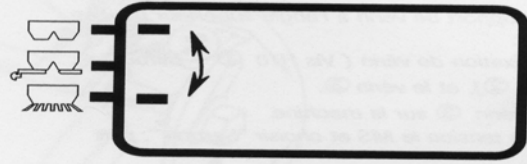
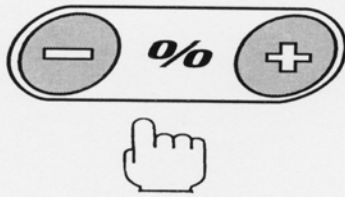

2

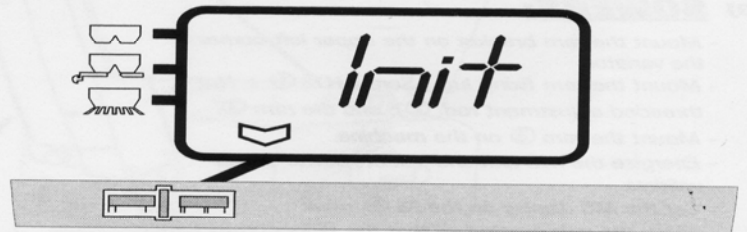

3

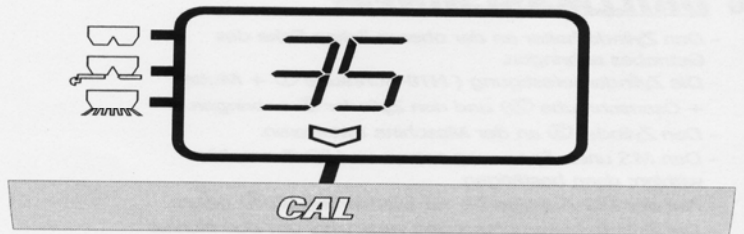

A Selecting the machine

- A ____ GLX - DPX
- B ____ DPA XL
- C ____ SOWERS

a) Selection

Turn the unit on.

1) Press

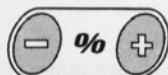

to select Sower or Dispenser (for XL see paragraph b).

2) Press



to save.

Press



again to continue.

➤ **Init** on the monitor.

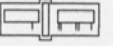

Adjustment to mark **35** and cursor on 



3) Switch to **CAL** mode.

See section **B** Flow rate tests.

Note: **35** is the mean value for flow rate testing.

Operation

B

1

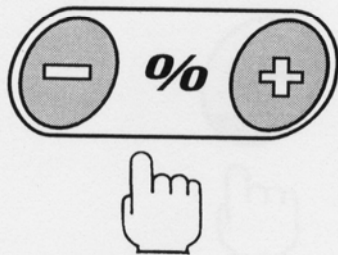

2

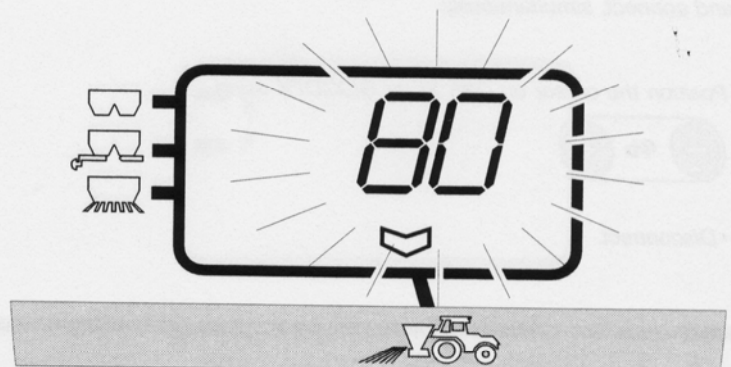

B Flow rate test

Make sure you are on **CAL** mode, **35** mark.
Perform the flow rate test (see the user's manual of the machine).

- 1) Weight the amount in kg (0,00).
Enter the value using

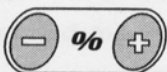

• **Note:**
for small values, entre 3 decimals.

- 2) Press



The unit computes and displays the dose in kg/ha.
(the dose flashes)

The cursor switches to 

Operation

B

1

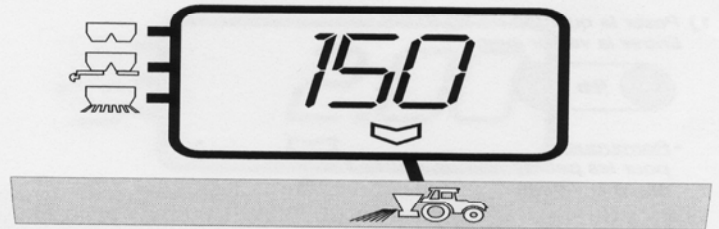

2

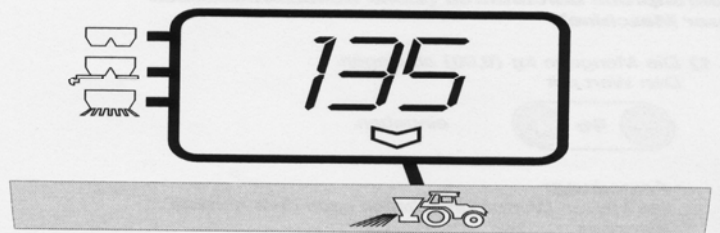
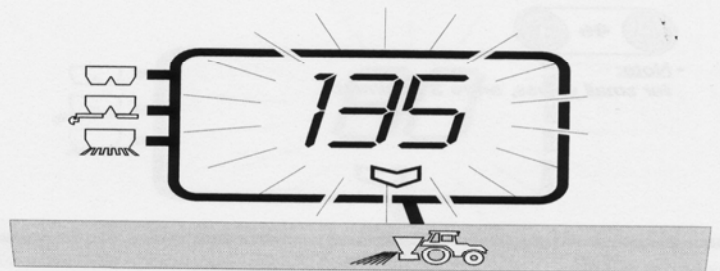
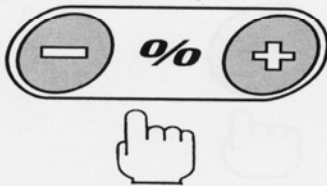

Two choices are available:

a) The dose displayed is as expected.

1) Press



You are ready to work.

b) The dose displayed differs with that expected.

1) Press

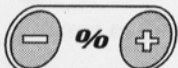

to modify the dose displayed.

2) Press



to save.

You are ready to work.

Operation

C

1

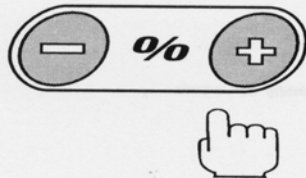
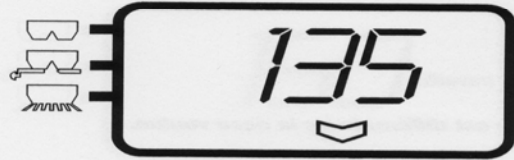
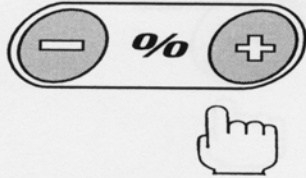

2

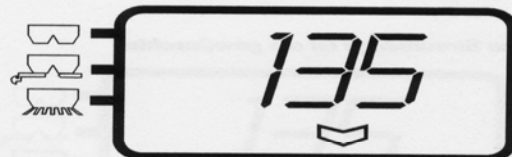

C Modulating the dose while working

1) Press

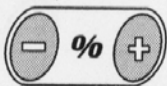

- Each pulse on the key induces a 10% increase.
- The cursor flashes.
- On the monitor, the modulated dose flashes together with the modulation percentage.

2) Press



to return to the reference dose.

Note: If the dose is set too high and the sower or dispenser cannot provide it, the amount displayed flashes.

Press



to return to the reference dose.

Operation

E

2

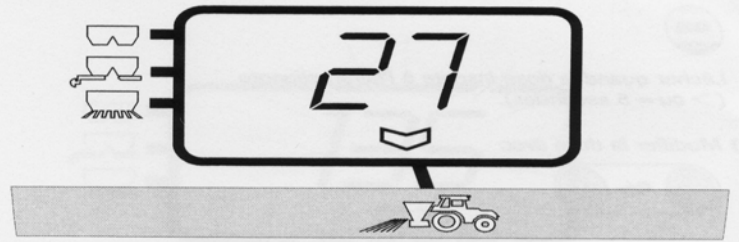

3

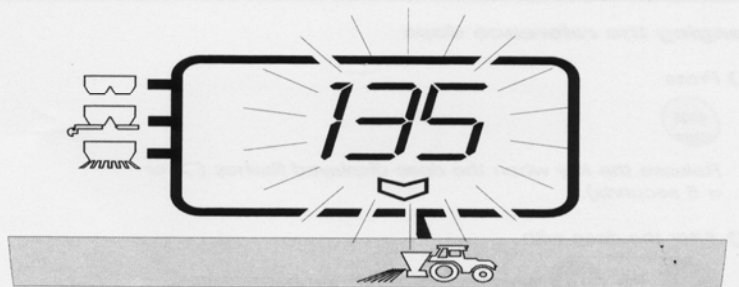
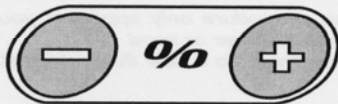

4

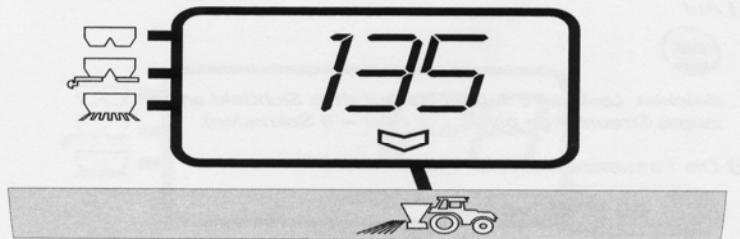

E Direct adjustment after the unit has been stopped

- The unit has memorized the latest adjustment made with the dispenser or sower.
- To proceed directly without going through the menu.

1) Start up the unit

2) Press



to validate the sower into dispenser.
The monitor displays the memorized index

3) Press



The monitor displays the dose, flashing.

4) Validate with



You are ready to work.
The reference dose will be the latest one used with the MS unit.

Optional Equipment

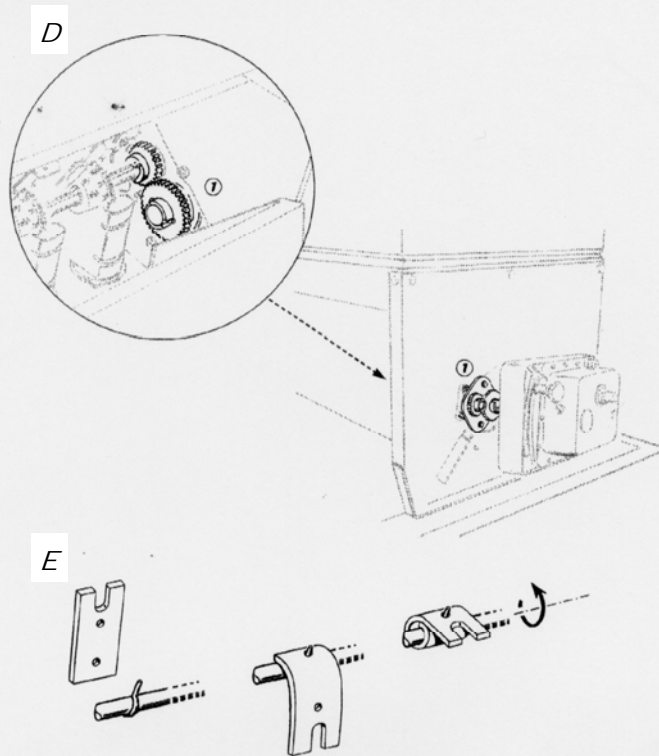

OPTIONAL EQUIPMENT

D) Variator Rotation Multiplier

- * The multiplier 1 must be used when working at speeds over 12 kph with high doses of fertiliser.

* Mounting

- Dismantle the variator.
- Remove the central coupling.
- Remove the multiplier, proceeding from outside.
- Insert the pin into the variator shaft.
- Remount the variator.

* Use

- The initial flow setting is multiplied by 2.
- Follow the indications in column B of the set-charts.

E) Flexible Agitator

- Use the flexible agitator for seeds that flow very poorly.

* Mounting

- Take the flexible rubber piece and roll it around the agitator tine as shown in the diagram.
- Note the rotation direction.

Optional Equipment

Multiplicator Installation Instructions

Step 1 Remove the four M8 Bolts that hold on the Variator

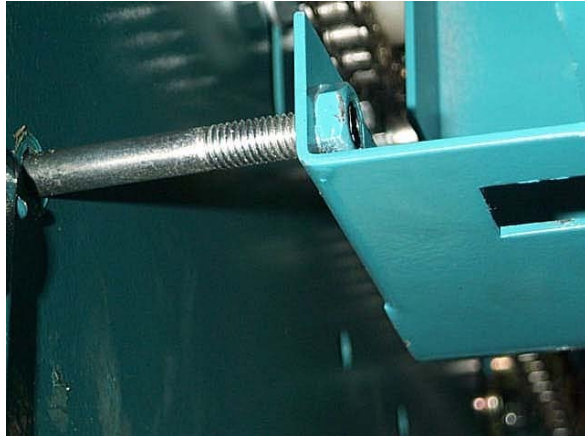

Step 2 Remove the Variator

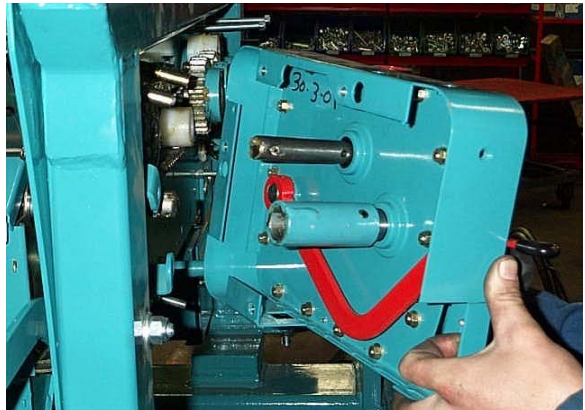

Step 3 Remove the two M8 X 20 bolts from the bracket. Place the keyed end sprocket over the Distribution shaft. Secure the bracket to the seedbox frame with the two M8 X 20mm bolts.

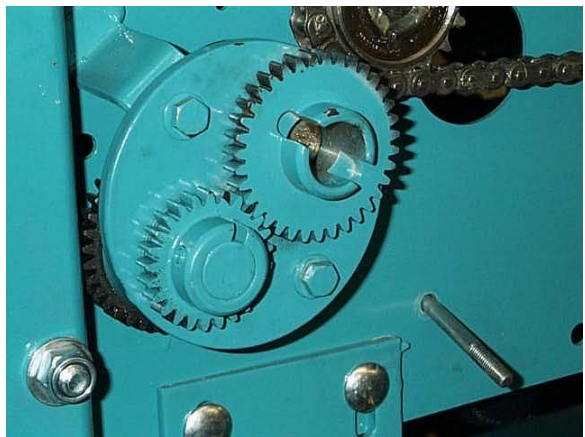

Step 4 Tighten the grub screw in the keyed sprocket onto the distribution shaft.

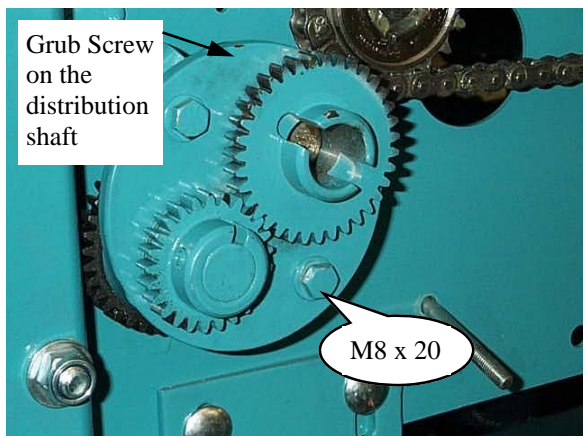

Step 5 Remove the collar from the shaft on the gearbox by punching out the roll pins.

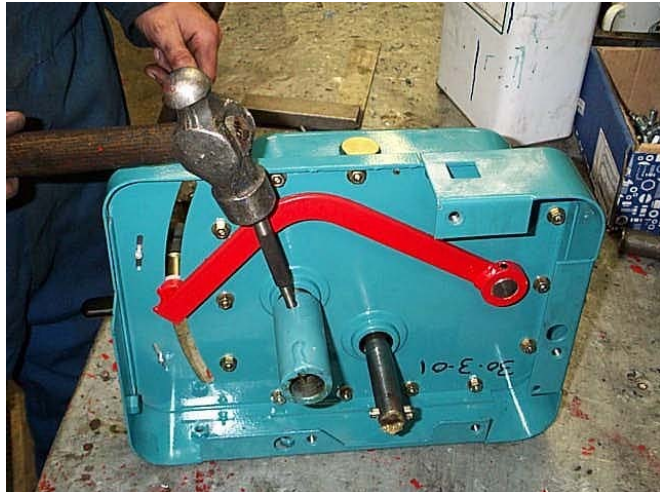

Step 6 Replace the roll pin that was taken out of the shaft to remove the collar

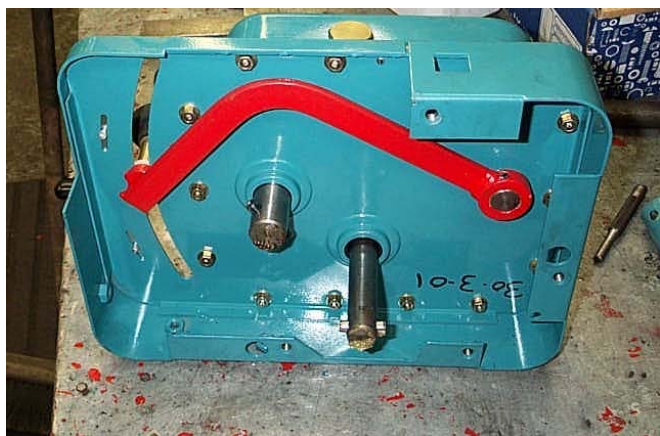

Step 7 Replace the variator onto the seedbox ensuring the long shaft with the roll pin connects with the keyed sprocket on the variator. Retighten the 4 M8 Bolts.



Optional Equipment

Electro Diverter Valve. Non Expert only.

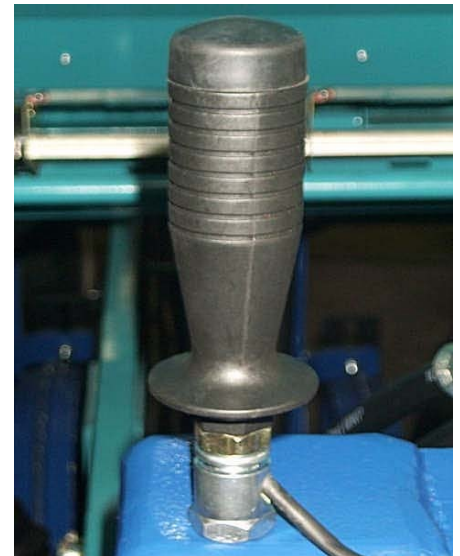
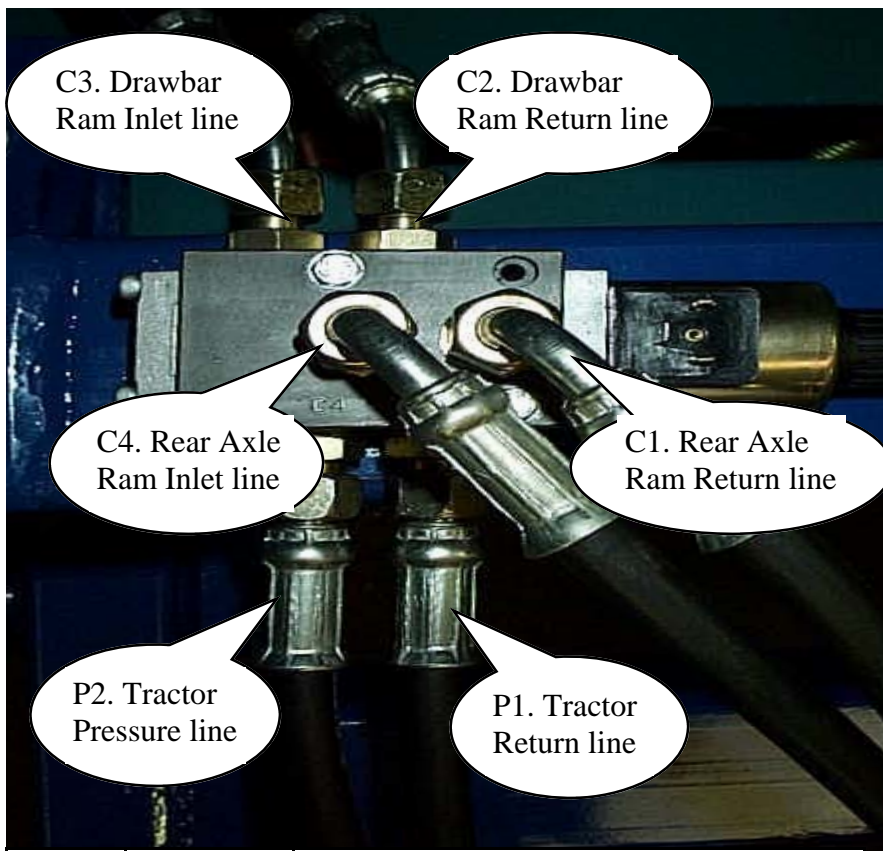

Trigger switch Joystick

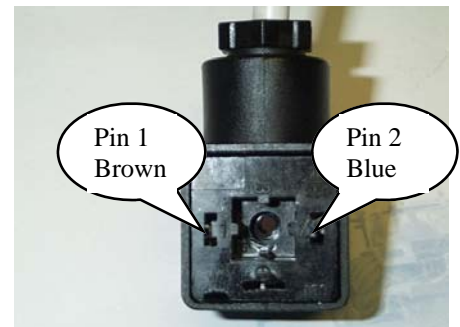

Electro Diverter Signal Herdsman

ITEM	PART No	DESCRIPTION
<i>P1</i>	HH3/4TH3/8	Tractor to Electro Diverter hose. Return Line
<i>P2</i>	HH3/4TH3/8	Tractor to Electro Diverter hose. Pressure Line
<i>C1</i>	H3/8DC3/8	Drawbar to Electro Diverter hose. Return Line
<i>C2</i>	H3/4CA3/8	Rear Axle to Electro Diverter hose. Return Line
<i>C3</i>	H3/4CA3/8	Rear Axle to Electro Diverter hose. Pressure Line
<i>C4</i>	H3/8DC3/8	Drawbar to Electro Diverter hose. Pressure Line

Electro Diverter Valve:

The Electro Diverter Valve is a valve block which controls the operation of two hydraulically operated functions. In this instance the functions are 1. Work or transport position adjustment of the rear axle, and 2. Depth adjustment of the drill via the drawbar cylinder.

Operation

Place the plug into the tractors 12 volt supply.

Attach the trigger switch Joystick to the appropriate double acting spool valve lever in the tractor cab.

The rear axle cylinders will extend / retract when the appropriate spool valve has been operated in the tractor.

When the button is pressed and held down on the joystick, and the appropriate spool valve has been operated in the tractor, the drawbar cylinder will extend / retract thus allowing depth adjustment of the drill.

Optional Equipment

Electro Diverter Valve.

Spool Valve lever mounting bracket for trigger switch joystick

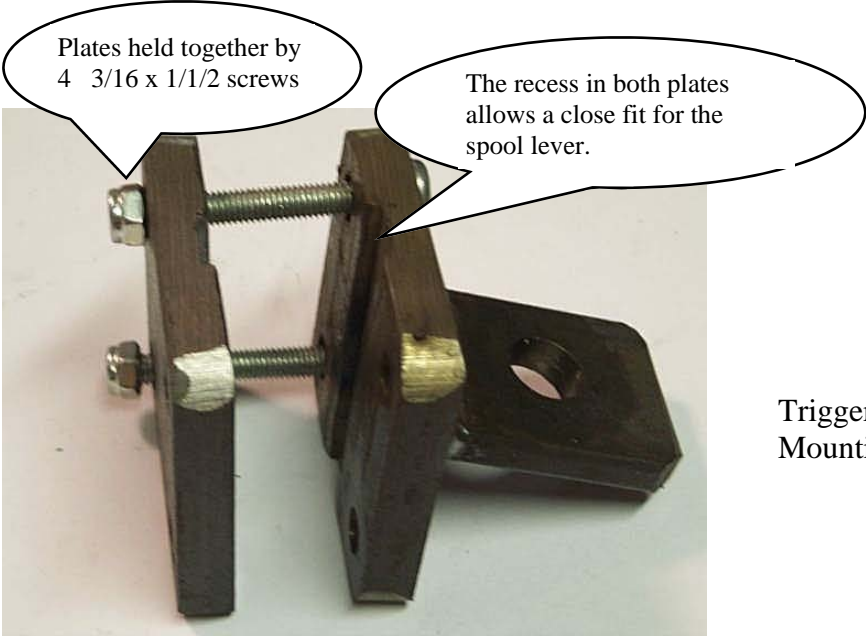

Trigger Switch Joystick Mounting Bracket.



Joystick Mounted to Bracket.

Optional Equipment

Pre Emergence Marker



Pre Emergence Marker

The Pre Emergence Marker allows a shallow mark to be left on the ground when the drill is on the tramline bout. The benefit of this application is to allow easy identification of the tramline bout for future passes over the crop such as slug pellet application or spraying.

Optional Equipment

Hydraulic or Air Brakes



Hydraulic or Air Brakes

Hydraulic brakes are optional on W400 and standard on W600.
Air Brakes are available for both W400 and W600 at additional cost.

Optional Equipment

Seedbox extension



Seedbox Extension

The seedbox Extension is standard on the W600 Seedbox and optional on the W400 Seedbox. The increase in capacity is approximately 600 litres.

Seedbox covers are standard on both W400 and W600.

When ordering parts always have the machine serial number at hand

Notes: _____



MOORE UNIDRILL LTD
33 KIRK ROAD, BALLYMONEY, Co ANTRIM
NORTHERN IRELAND BT53 6PP

TEL: (++44) 028276 64444
FAX: (++44) 028276 65696
EMAIL: info@moore-unidrill.com
WEBSITE: www.moore-unidrill.com

Parts list

Dragarm Seeding Unit

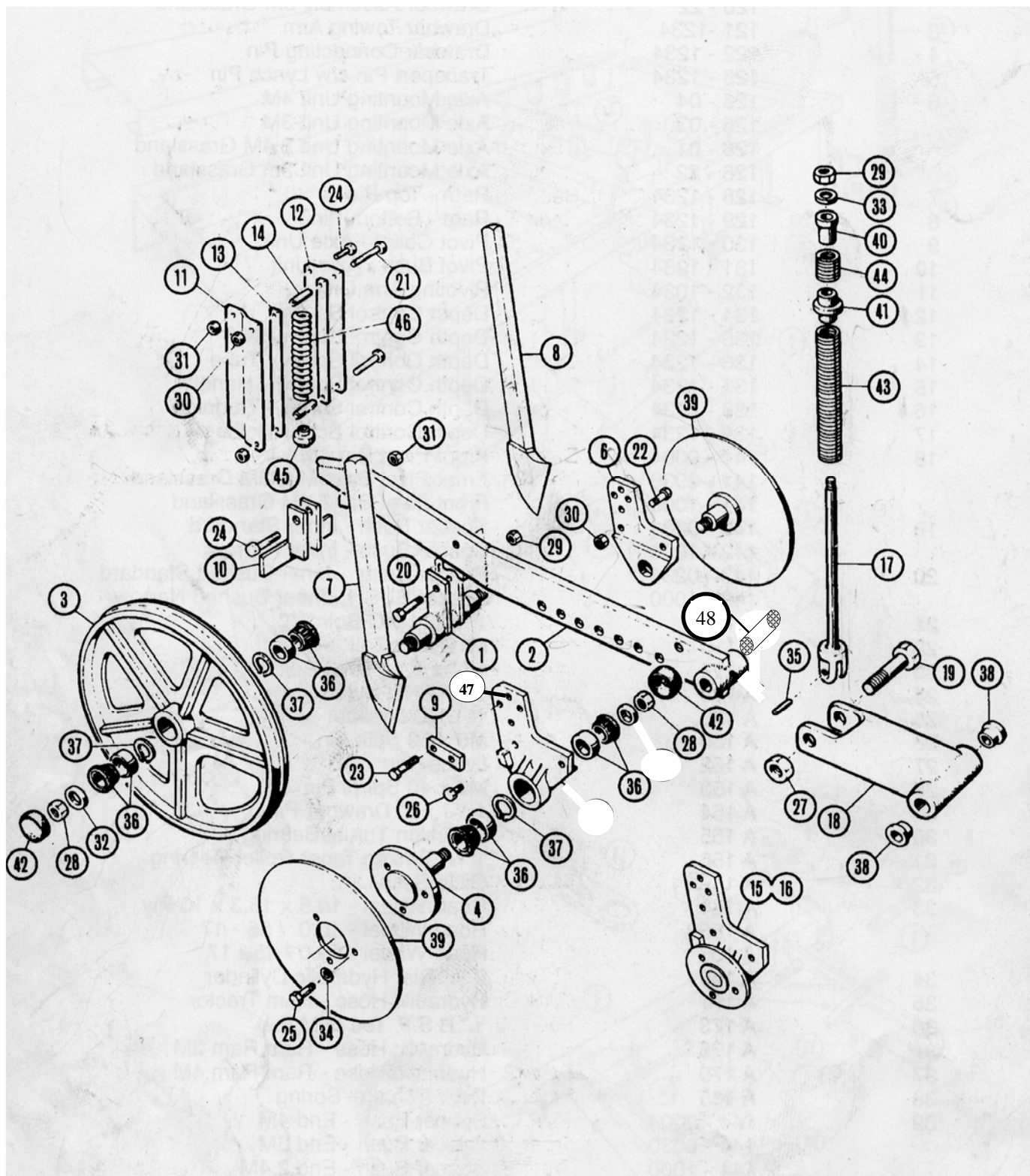

Parts list

Dragarm Seeding Unit

ITEM	PART No	DESCRIPTION	ITEM	PART No	DESCRIPTION
1	201-0234	Dragarm Axle Unit.	17	217-1234	Front Spring Arm
	201-1000N	Dragarm Axle unit Grassland Straight	18	132-1034N	Pivot Arm Unit
	201-6N	Dragarm Axle unit Grassland Stepped	19	A103N	Pivot Arm Pin
	201-40N	Dragarm Axle unit Arable Bogie	20	A107	M16 X 50 Bolt
	1.4A	Dragarm Axle unit Arable Stepped	21	A110	M12 X 75 Bolt
	201-0034	Dragarm Axle unit Arable Straight	22	A111	M12 X 55 Bolt
2	220-1A	Dragarm Mounting Bar	23	A118	M10 X 70 Bolt
3	203-1034N	Press Wheel Large.	24	A114	M10 X 50 Bolt
4	204-1234	Disc Hub	25	A119	3/8" X 3/4" Setscrew
5	205-34	Disc Mounting Bracket R.H.	26	A120	M10 X 20 Setscrew
	205-34G	Disc Mounting Bracket R.H. Grassland	27	A251	1" UNF Binx nut
6	206-34	Disc Mounting Bracket L.H.	28	A132	3/4 UNF Locknut
	206-34G	Disc Mounting Bracket L.H. Grassland	29	A137	M16 Locknut
7	207-1234L	Seed Tube Coulter—R.H. 30mm	30	A138	M12 Locknut
	207-1234LT	Seed Tube Coulter—R.H. 30mm Tungsten	31	A139	M10 Locknut
	207-1234LTG	Seed Tube Coulter—R.H. 30mm Tungsten Grass	33	A146	M16 X 34 H.D. Washer
8	208-1234L	Seed Tube Coulter—L.H. 30mm	34	A148	3/8" Spring Washer
	208-1234LT	Seed Tube Coulter—L.H. 30mm Tungsten	35	A149	1/2" X 1 3/4" Spirol Pin
	208-1234LTG	Seed Tube Coulter—R.H. 30mm Tungsten Grass	36	A157N	1" Timken Taper Roller Bearing
9	209-1234L	Seed Tube Retaining Plate	38	A159	Oilite Bush
10	210-1000	Press Wheel Scraper Grassland	39	A160L	Seed Disc Coulter 18"
	A204	Super Scraper	40	A180	Spring Retaining Bush
	A281-1A	Super Scraper mounting bracket	41	A181	Spring Locating Bush
11	211 - 1234W	Dragarm Guide Plate R.H.	42	A182	Dust Cap - Small
12	212 - 1234W	Dragarm Guide Plate L.H.	43	A186	Front Spring - Lower
13	213-1234	Guide Plate Bar	44	A187	Front Spring - Upper
14	214-1234W	Guide Plate Distance Piece	45	A188	Rear Spring Bush
15	1.91A	Disc Bearing Replacement Unit—R.H.	46	A533	Rear Spring. Heavy Duty
	1.911	Disc Bearing Replacement Unit—R.H. Grassland	47	A122	M10 X 25 Setscrew
16	1.81A	Disc Bearing Replacement Unit—L.H.	48	A521	Igus Bush Z Type
	1.811	Disc Bearing Replacement Unit—L.H. Grassland			

Parts list

Dragarm Axle Units

Arable Drills



Arable Drill Stepped Axle Unit. Part No: 1.4AN



Arable Drill Stepped axle scrapper mounting bar. Part No: 2.62A



Arable Drill Bogie Axle and Super Scrapper. Complete Assembly Part No: 201 - 40N

Bogie Axle Parts

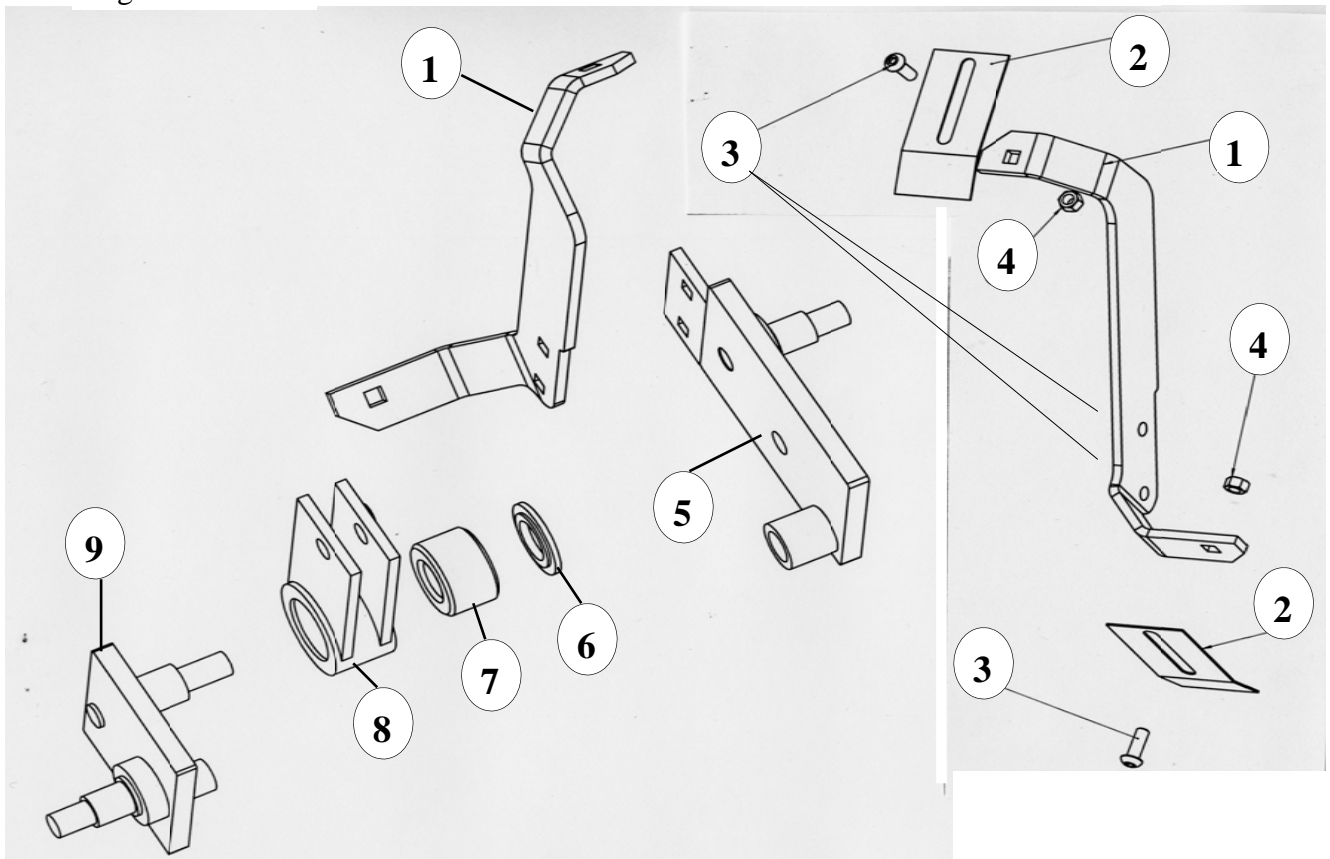

Parts list

Bogie Axle Assembly

ITEM	PART No	DESCRIPTION
<i>1</i>	A281-1A	Super Scraper Mounting Bracket
<i>2</i>	A204	Scraper
<i>3</i>	A127	Mounting Bracket Bolt. M12 X 30 Cup Square
	A127	Scraper Mounting Bolt M12 X 30 Cup Square
<i>4</i>	A138	Nut M12 Nyloc
	A138	Nut M12 Nyloc
<i>5</i>	1.303A	Bogie Long Arm
<i>6</i>	201-4E	Bogie Spacer
<i>7</i>	A151	Unipack Bearing 30mm
<i>8</i>	201-43	Bogie Mount
<i>9</i>	201-42N	Bogie Short Arm

Parts list

4M Drawbar, Rear Axle and Chassis Assembly

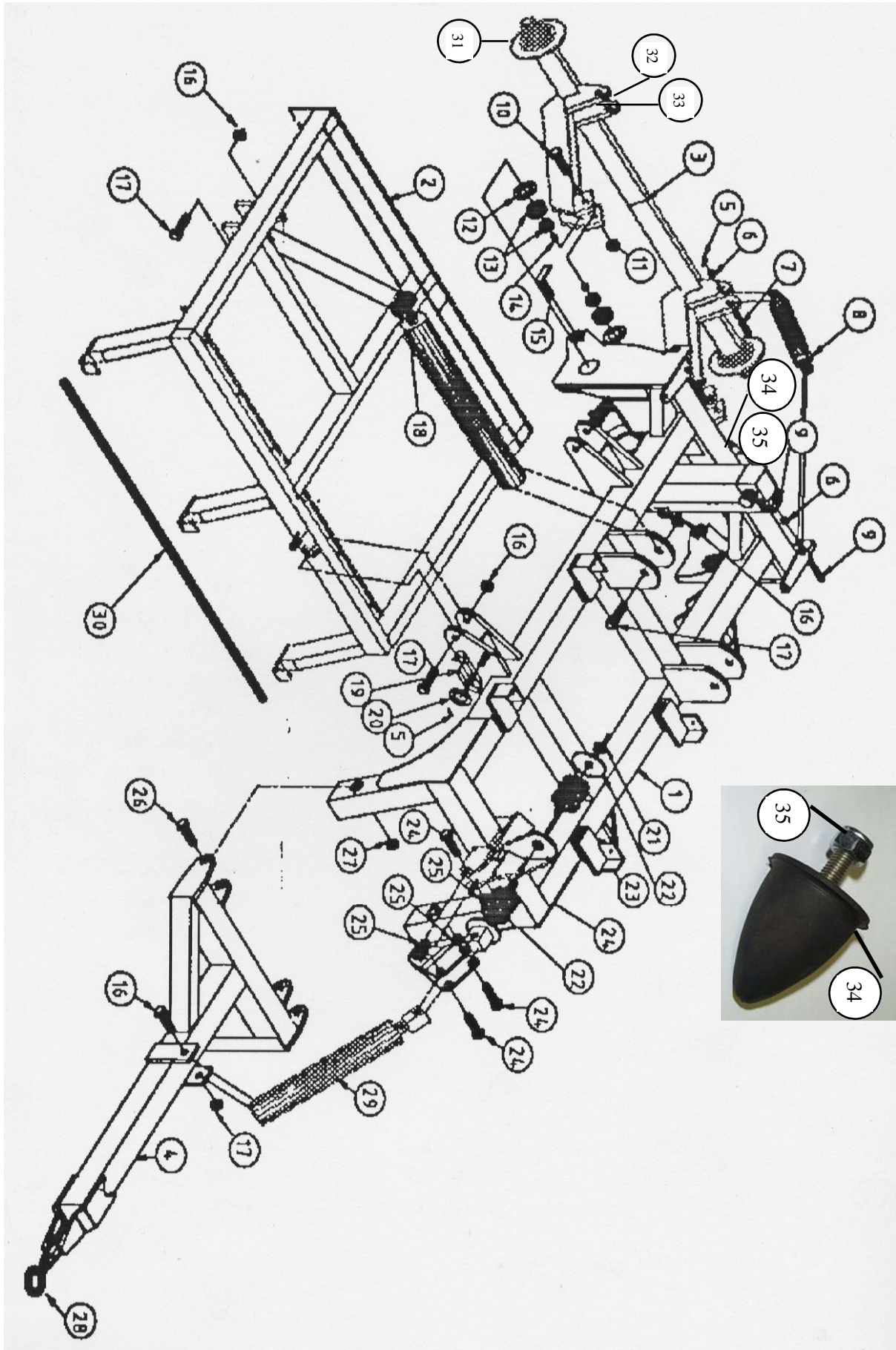

Parts list

4M Drawbar, Rear Axle and Chassis Assembly

ITEM	PART No	DESCRIPTION	ITEM	PART No	DESCRIPTION
1	W4.200A	4M HP Chassis	19	_____	_____
2	W4.100A	4M HP Wing	20	_____	_____
3	W6.400A	Axle Unit	21	W6.220	Spring Collar Unit
4	W4.300A	Drawbar	22	MU 10-14	Depth Control Spring
5	A153	M8 x 40 Roll Pin	23	W6.201A	Spring Pressure Adjustment Bolt
6	A199	1"1/4 x 1" Hardened bush	24	A117A	1"1/4 x 5" UNC Bolt
7	129-1234	Axle to Ram Pin	25	A129	1" 1/4 UNC Nut
8	BAC358	Rear Axle Ram	26	W6.241	1"1/4 x 8" UNC Bolt
9	122-1234N	Ram to Chassis Pin	27	A129	1" 1/4 UNC Nut
10	A101	1" x 6" UNC Bolt	28	10053	Swivel Hitch
11	A130	1" UNC Bolt	29	BAC093	Depth Control Ram
12	130-1234	Pivot Collar Axle Unit	30	W4.108	Front Pivot Bar
13	A156	1" 3/8 Taper Roller Bearing	31	A166HP	Road Wheel 500/50 - 17
14	131-1234	Pivot Bush Axle Unit	32	S8897	Red Reflector
15	125-1234	Transport Pin	33	B40	M8 x 30 Bolt
16	A129B	1"1/4 UNC Nyloc		A140	M8 Nut Nyloc
17	A117	1"1/4 x 7"1/2 UNC Bolt	34	S793704	Rubber Buffer
18	BAC808	Wing Ram	35	A139	M10 Nut Nyloc

Parts list

6M Drawbar, Rear Axle and Chassis Assembly

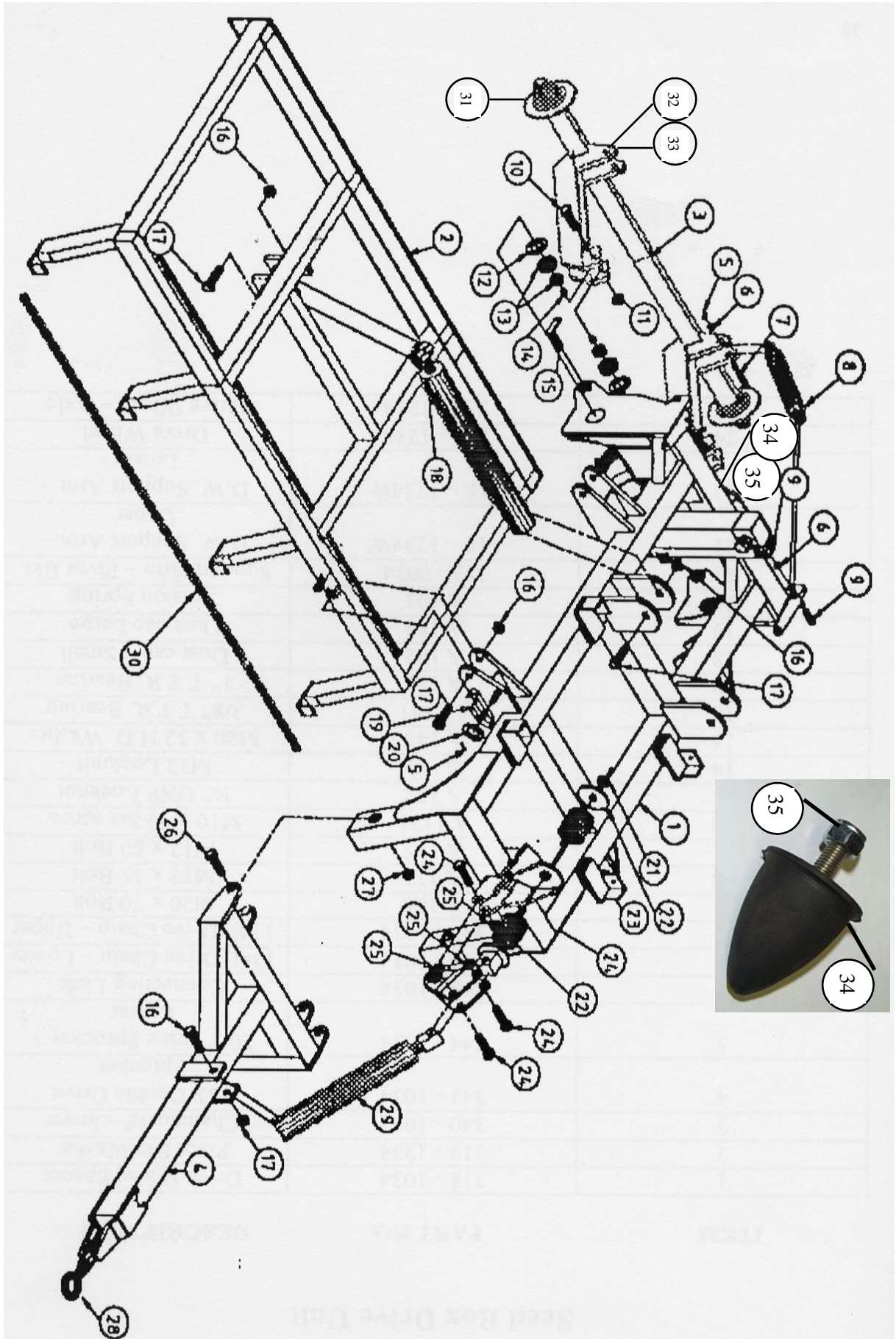

Parts list

6M Drawbar, Rear Axle and Chassis Assembly

ITEM	PART No	DESCRIPTION	ITEM	PART No	DESCRIPTION
1	W6.200A	6M HP Chassis	19	_____	_____
2	W6.100A	6M HP Wing	20	_____	_____
3	W6.400A	Axle Unit	21	W6.220	Spring Collar Unit
4	W6.300A	Drawbar	22	MU 10-14	Depth Control Spring
5	A153	M8 x 40 Roll Pin	23	W6.201A	Spring Pressure Adjustment Bolt
6	A199	1"1/4 x 1" Hardened bush	24	A117A	1"1/4 x 5" UNC Bolt
7	129-1234	Axle to Ram Pin	25	A129	1" 1/4 UNC Nut
8	BAC358	Rear Axle Ram	26	W6.241	1"1/4 x 8" UNC Bolt
9	122-1234N	Ram to Chassis Pin	27	A129	1" 1/4 UNC Nut
10	A101	1" x 6" UNC Bolt	28	10053	Swivel Hitch
11	A130	1" UNC Bolt	29	BAC093	Depth Control Ram
12	130-1234	Pivot Collar Axle Unit	30	W6.108	Front Pivot Bar
13	A156	1" 3/8 Taper Roller Bearing	31	A166HP	Road Wheel 550/45 - 22.5
14	131-1234	Pivot Bush Axle Unit	32	S8897	Red Reflector
15	125-1234	Transport Pin	33	B40	M8 x 30 Bolt
16	A129B	1"1/4 UNC Nyloc		A140	M8 Nut Nyloc
17	A117	1"1/4 x 7"1/2 UNC Bolt	34	S793704	Rubber Buffer
18	BAC808	Wing Ram	35	A139	M10 Nut Nyloc

Parts list

Drive wheel Assembly

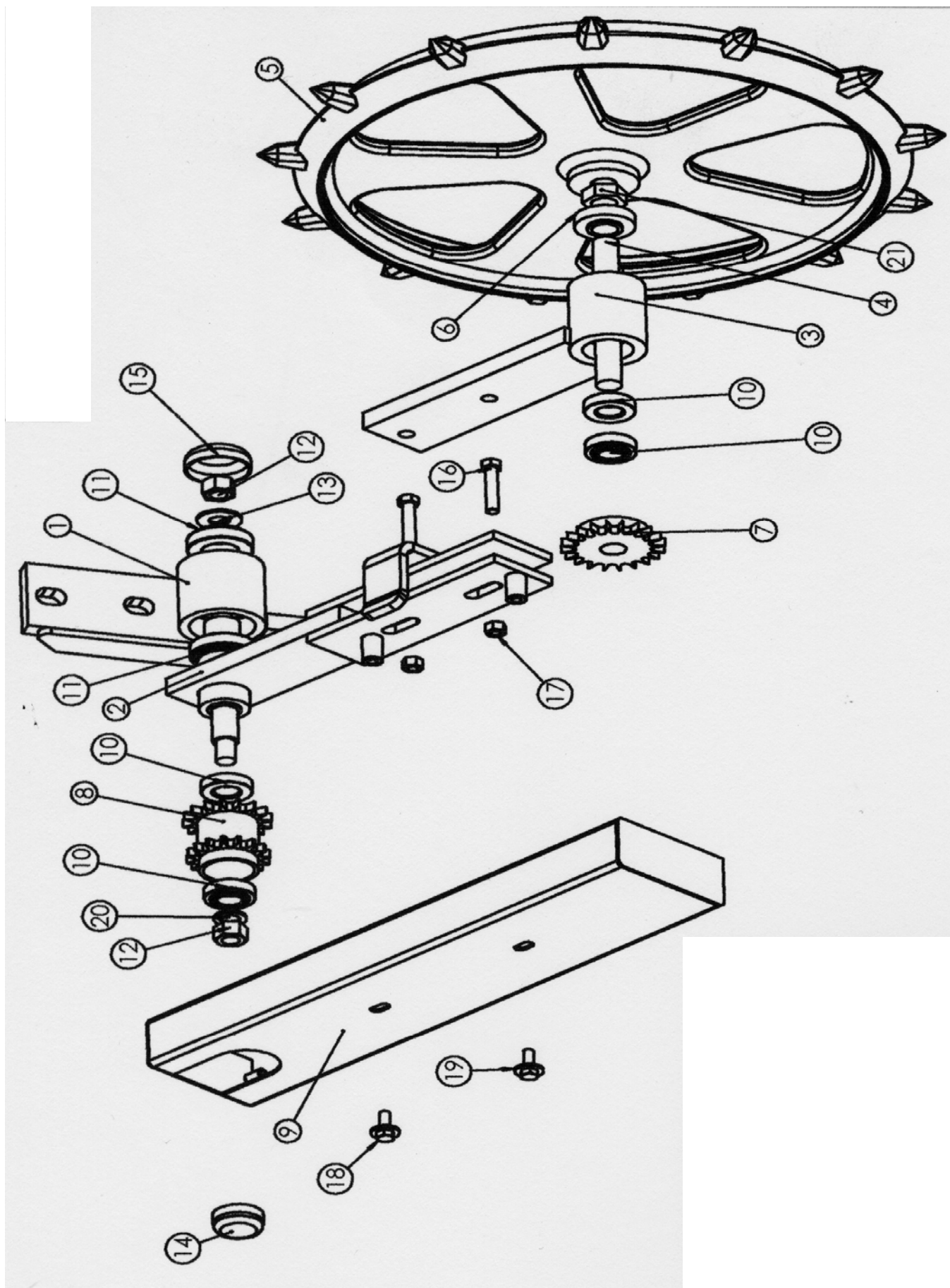

Parts list

Drive wheel Assembly

ITEM	PART No:	DESCRIPTION
<i>1</i>	W6.701A	Support Arm - Pivot Bracket
<i>2</i>	W6.702A	Drive Wheel Support Arm - Upper
<i>3</i>	W6.703A	Drive Wheel Support Arm - Lower
<i>4</i>	3.106	Drive Wheel Axle
<i>5</i>	3.112	Drive Wheel
<i>6</i>	3.108	Bearing Pivot Collar
<i>7</i>	S900596	20 Tooth Sprocket
<i>8</i>	S900594	16 Tooth Double Sprocket
<i>9</i>	W6.704A	Lower Drive Wheel Guard
<i>10</i>	A157N	1" Timken Duo Seal Bearing
<i>11</i>	A156	1 3/8" Timken Taper Roller Bearing
<i>12</i>	A132	3/4" UNF Locknut
<i>13</i>	319-1234	Bearing Pivot Washer
<i>14</i>	A182	Small Dust Cap
<i>15</i>	A183	Large Dust Cap
<i>16</i>	A111	M12 x 55 Bolt
<i>17</i>	A138	M12 Nyloc
<i>18</i>	A263	M10 X 25 Setscrew
<i>19</i>	A148	3/8" Spring Washer
<i>20</i>	A145	M20 x 32 H.D. Washer
<i>21</i>	A130	1" UNC Nut

Parts list

Angle Gearbox Drive Unit

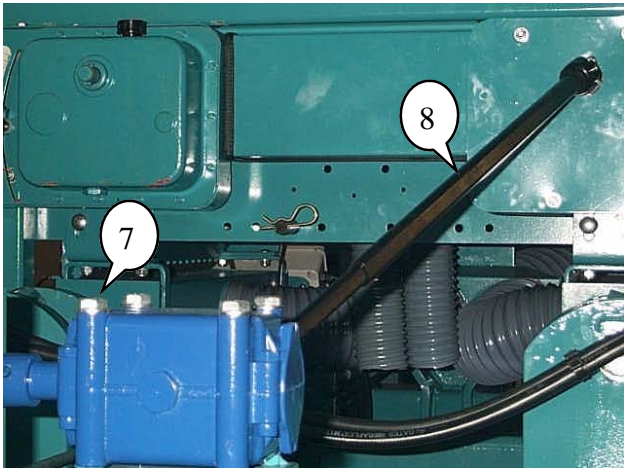
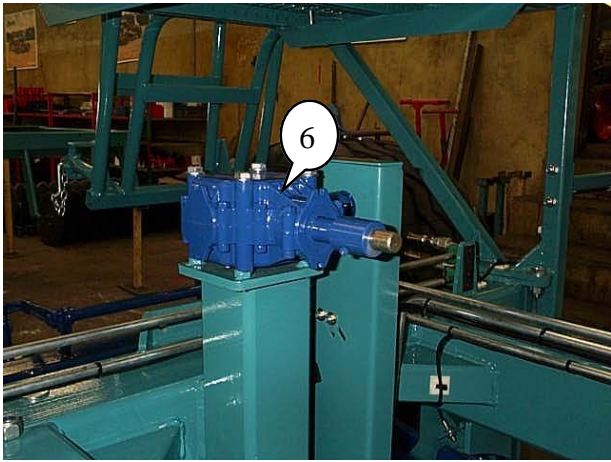
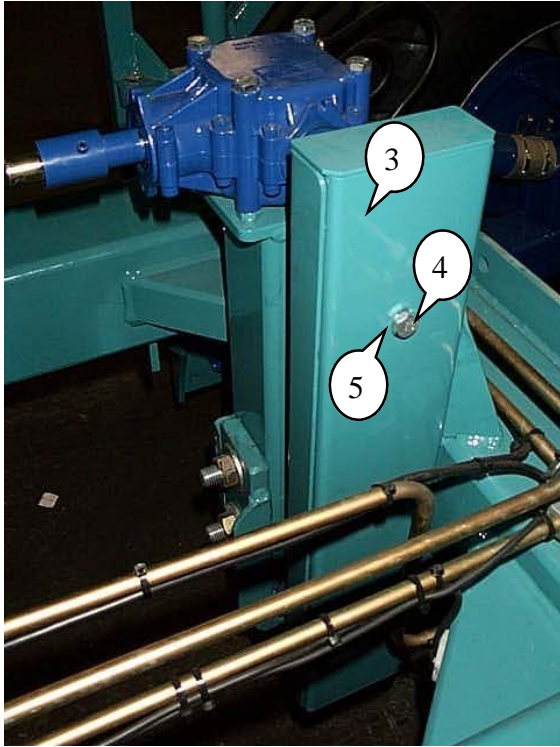
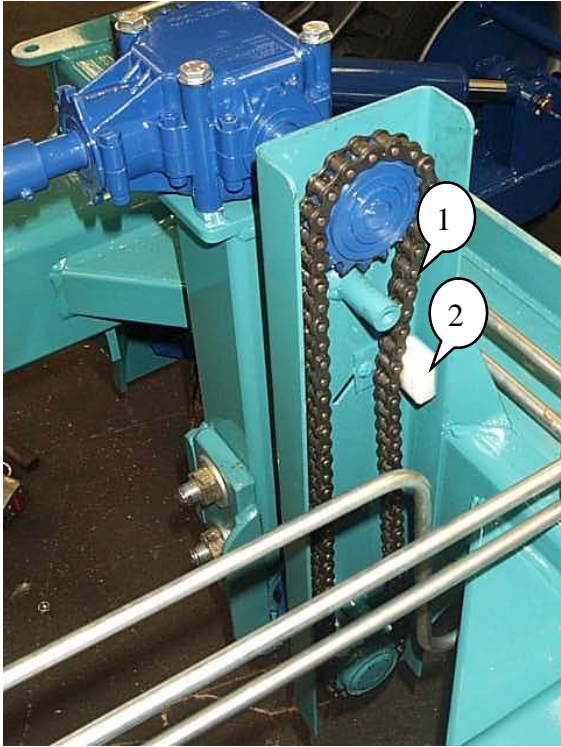

Parts list

Angle Gearbox Drive Unit

ITEM	PART No	DESCRIPTION
<i>1</i>	DC 5/8	5/8 Drive Chain
<i>2</i>	S991337	Chain Tensioner
<i>3</i>	W6.705A	Chain Guard Upper
<i>4</i>	A214	M10 x 80 Bolt
<i>5</i>	A148	3/8 Spring Washer
<i>6</i>	S907535	Angle Gearbox
<i>7</i>	A262	M10 x 120 Bolt
<i>8</i>	S922033	Drive Shaft

Parts list

Seed Box Drive Unit

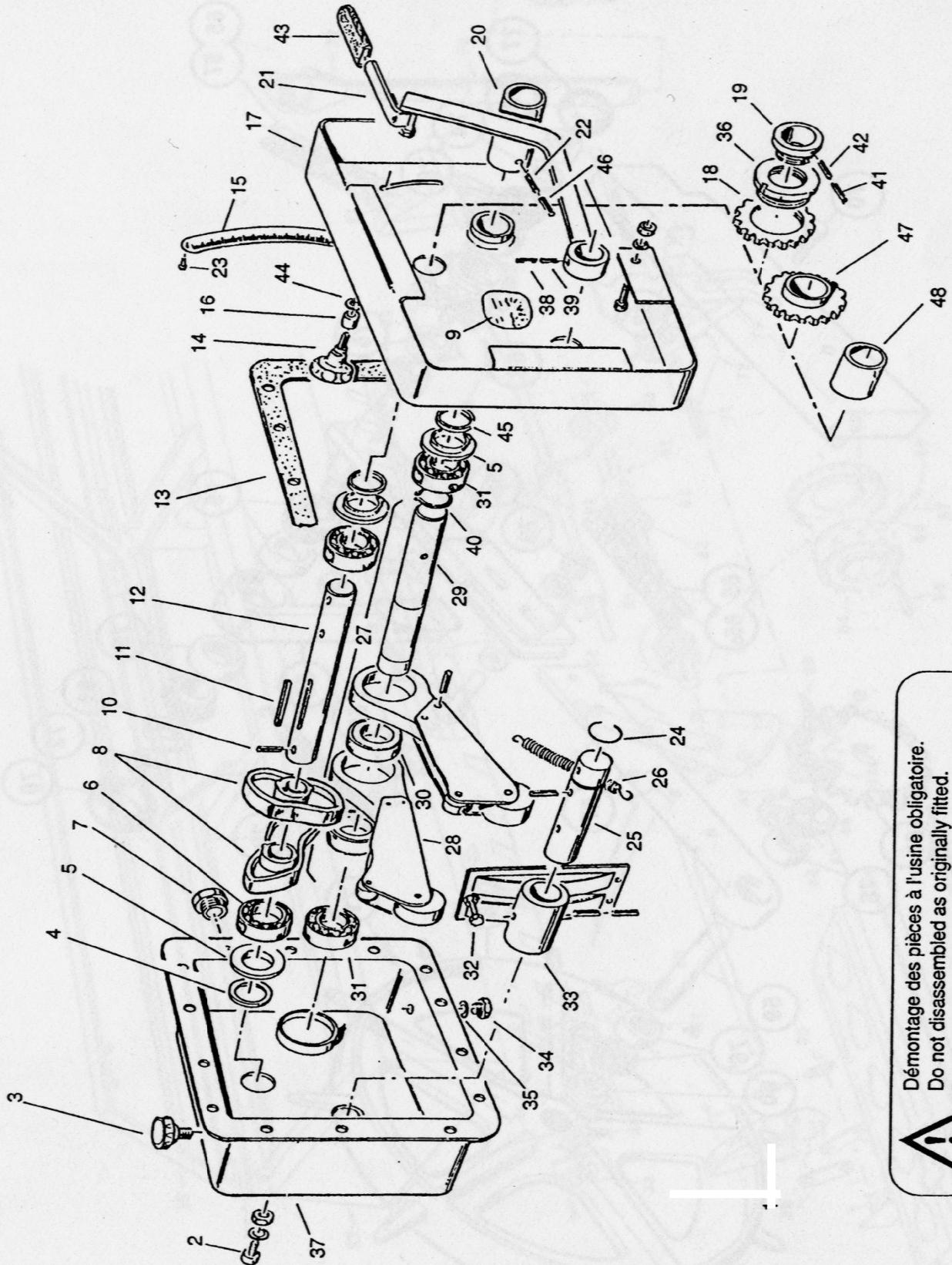

 Démontage des pièces à l'usine obligatoire.
Do not disassemble as originally fitted.
Die werkseitig eingebauten teile nicht abmontieren.

Parts list

Seed Box Drive Unit

ITEM	PART No	DESCRIPTION	ITEM	PART No	DESCRIPTION
1	S910221	Variator 2	24	S732001	Circlip 2.65 X 15.1
2	S553612	Allen Screw 6 X 12	25	S922029	Plateau Shaft
	S573107	Washer M6	26	S981008	Lever Spring
	S571206	Nut M6	27	S910239	Freewheel Assembly
3	S795060	Oil Filter Plug	28	S914022	Cam Lever
4	S751005	Seal 20 X 35 7	29	S922031	Freewheel Shaft
5	S963080	Butt Join	30	S712013	Freewheel Bearing
6	S711010	Bearing 6204 20 X 47 X 14	31	S711009	Bearing 6005 25 X 47 X 12
7	S795070	Lubricant Indicator	32	S551684	Screw 6 X 30
8	S935002	Double Cam	33	S915013	Plateau
9	S480002	Dextron 1 Litre	34	S984008	Oil Drain Plug
10	S590306	Roll Pin 6 X 30	35	S737003	Oil Drain Seal
11	S596875	6 X 56 Key	36	S712014	Freewheel Collar
12	S922033	Drive Shaft	37	S914025	Variator Cover
13	S987703	Gasket	38	S590106	Spirol Pin 3.5 X 30
14	S910296	Handle 8 X 40	39	S590307	Spirol Pin 6 x 35
15	S989002	Scale	40	S574225	Circlip Dia 25
16	S925027	Spacer	41	S590306	Spirol Pin 6 x 30
17	S918096	Variator Chain Guard	42	S590106	Spirol Pin 3.5 X 30
18	S901040	Freewheel Sprocket	43	S415749	Lever Tip 14 X 4 X 50
19	S923043	Freewheel Inner Bush	44	S573158	Washer M8
20	S915014	Distribution Collar	45	S751005	Seal 20 X 35 7
21	S915012	Distribution Lever	46	S590257	Spirol Pin 5 X 35
22	S89407	Spirol Pin 8 X 35	47	S980753	Pinion
23	S598041	Rivet 4 X 10	48	S925042	Pinion Insert

Parts list

Multiplicator

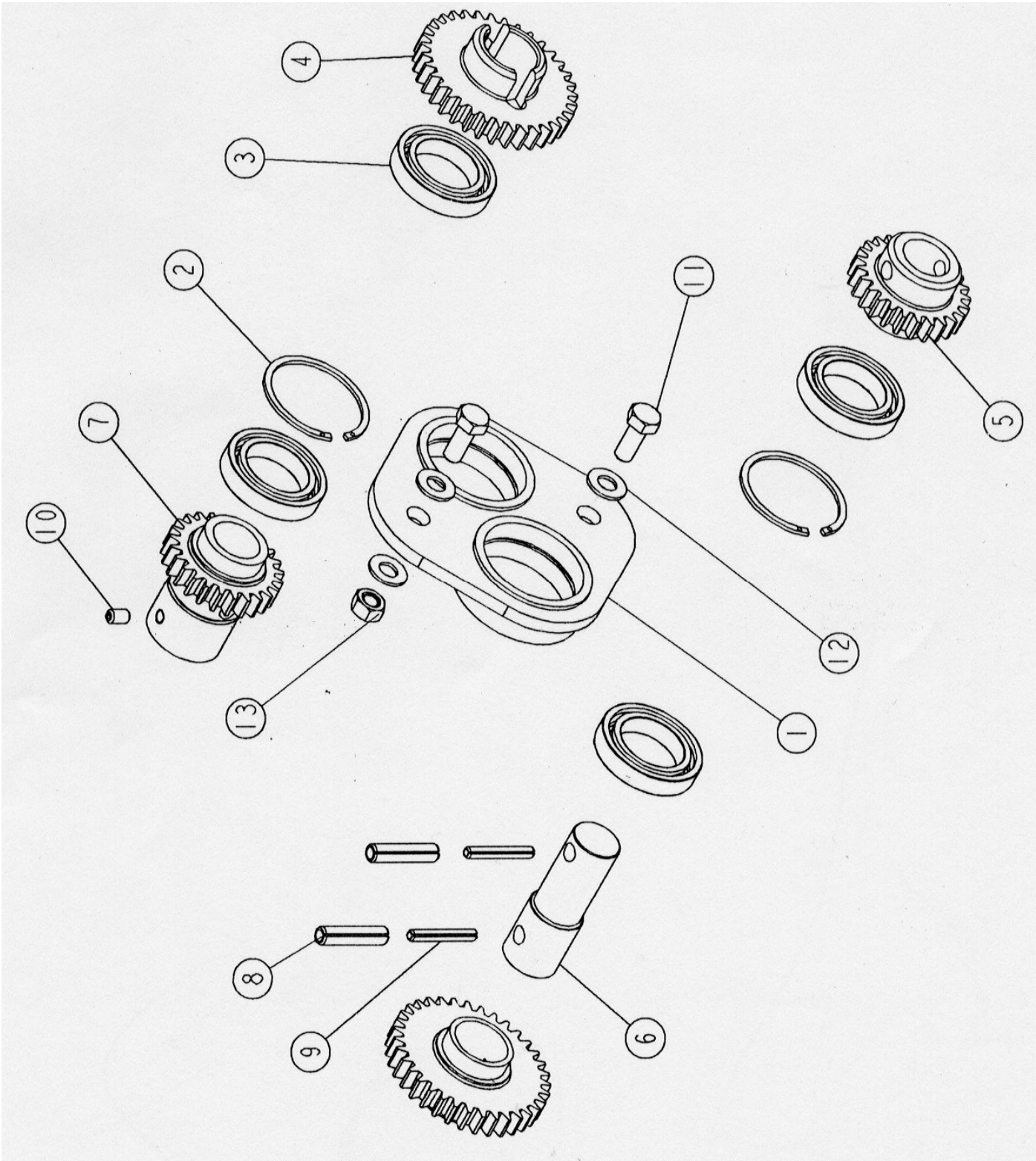

Parts list

Multiplicator

ITEM	PART No	DESCRIPTION
<i>1</i>	S914114	Multiplicator Bracket
<i>2</i>	S574225	Circlip
<i>3</i>	S711015	Bearing 30 x 47 x 9
<i>4</i>	S980781	Sprocket 35 Tooth
<i>5</i>	S980780	Sprocket 25 Tooth
<i>6</i>	S930024	Sprocket Bar
<i>7</i>	S915041	Multi Sprocket 25 Tooth
<i>8</i>	S590407	Roll Pin M8 x 35
<i>9</i>	S590207	Roll Pin M5 x 35
<i>10</i>	S554610	M6 x 10 Grub Screw
<i>11</i>	A219	M8 x 20 Bolt
<i>12</i>	S573158	M8 Washer
<i>13</i>	S571208	M8 Nut

Parts list

MS Flow Modulation

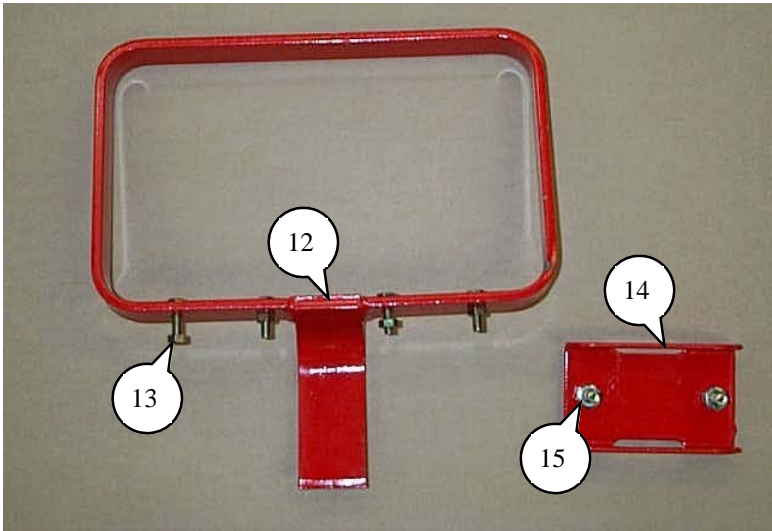
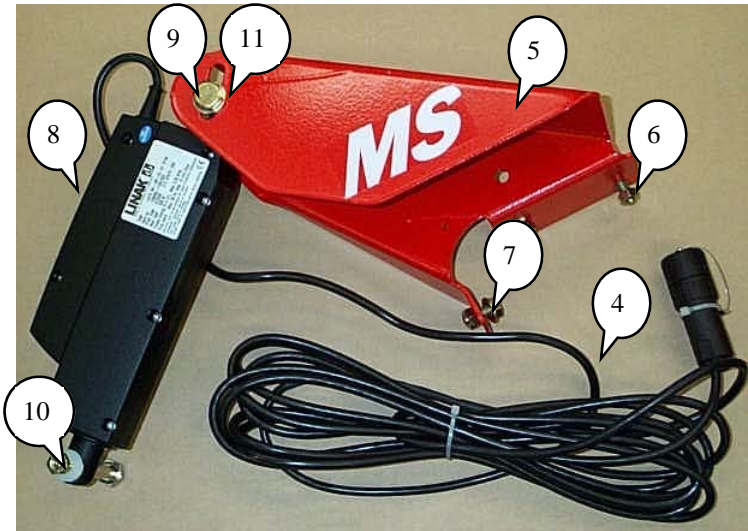
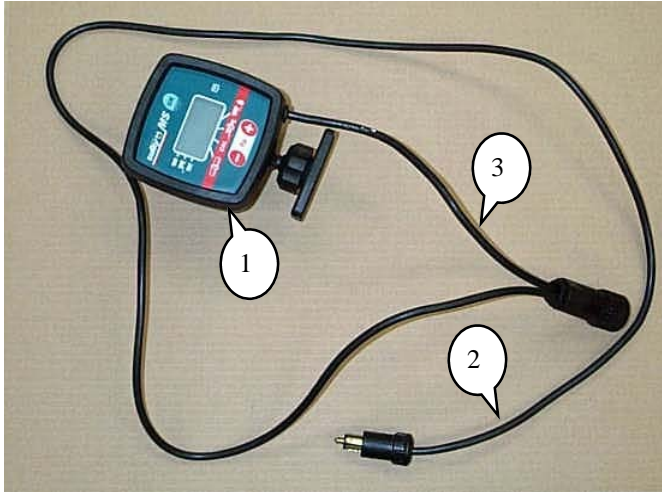

Parts list

MS Flow Modulation

Item Number	Part Number	Description
<i>1</i>	MS - 01	MS control pod
<i>2</i>	MS - 02	MS control pod power lead
<i>3</i>	MS - 03	Lead from MS pod to sensor
<i>4</i>	MS - 04	Lead from linak actuator to sensor
<i>5</i>	MS - 05	Linak actuator mounting bracket
<i>6</i>	MS - 06	Mounting bracket setscrews. M8 x 20
<i>7</i>	MS - 07	M8 Washer
<i>8</i>	MS - 08	Linak actuator
<i>9</i>	MS - 09	Linak actuator top bolt. M10 x 100
<i>10</i>	MS - 10	Linak actuator bottom bolt. M10 x 100
<i>11</i>	MS - 11	M10 Washer
<i>12</i>	MS - 12	MS pod mounting bracket
<i>13</i>	MS - 13	Ms pod mounting bracket setscrews. M6 x 20
<i>14</i>	MS - 14	Mounting bracket clamp
<i>15</i>	MS - 15	Mounting bracket clamp setscrews. M8 x 35

Parts list

Headland Splitter-Distribution Mechanism

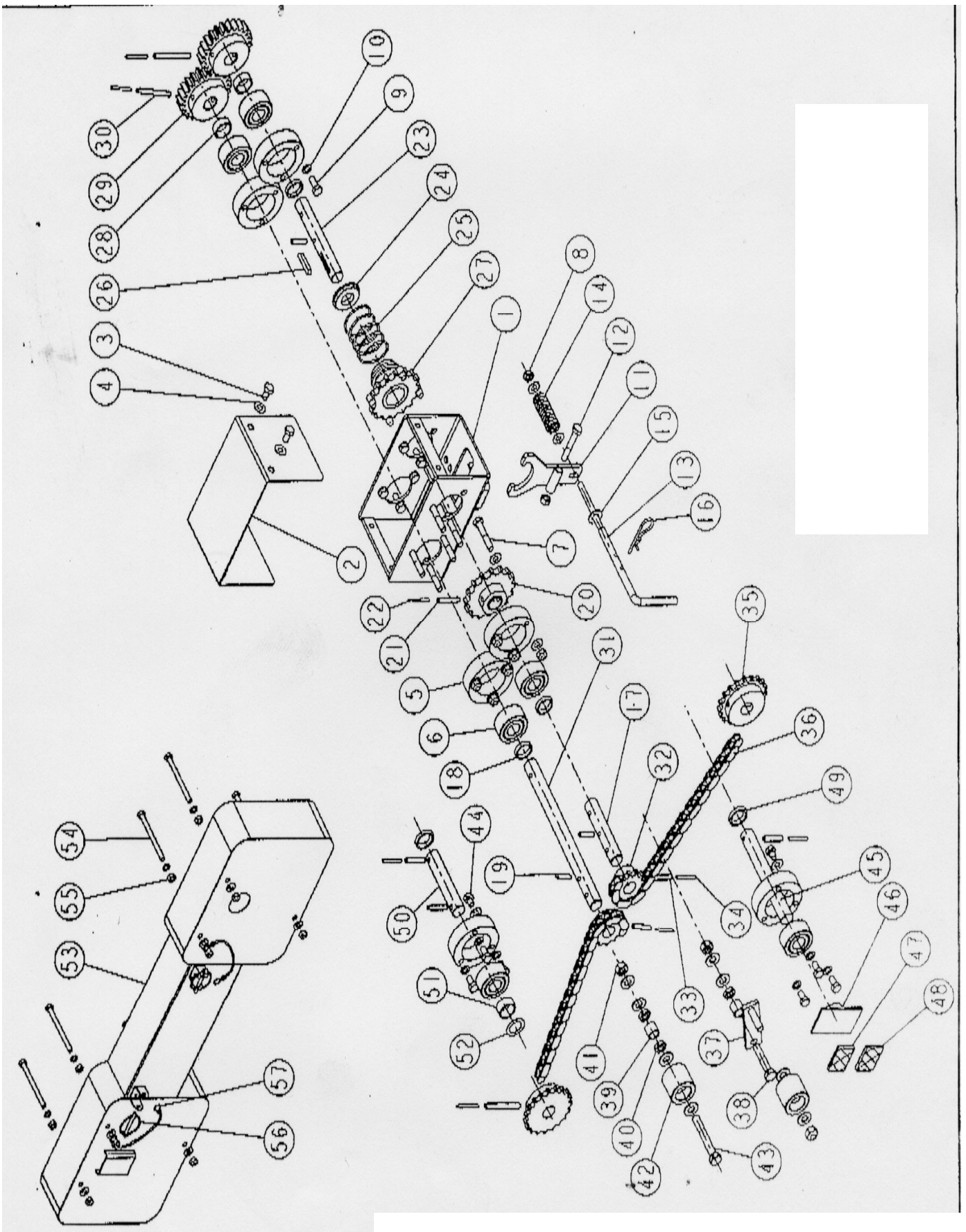

Parts list

Headland Splitter-Distribution Mechanism

Item No	Part No:	Description	Item No	Part No:	Description
1	S1091765	Headland splitter mounting box	30	S590313	Roll Pin M6 x 65
2	S991529	Headland splitter box cover	31	S992374	Sprocket axle (secondary)
3	S551865	M8 x 15 Bolt	32	S993116	Sprocket 2 (primary axle)
4	S573158	M8 Washer	33	S590301	Roll Pin M6 x 35
5	S992046	Bearing Carrier	34	S589108	Roll Pin M3.5 x 35
6	S720348	Bearing	35	S993171	Sprocket (Agitator Shaft)
7	S525895	M8 x 45 Bolt	36	S993171C	Transmission chain
8	A140	M8 Nut Nyloc	37	S991337	Chain Tensioner
9	A219	M8 x 20 Bolt	38	S552100	M10 x 50 Bolt
10	S573158	M8 Washer	39	S905358	Spacer
11	S1091766	Shut-off handle guide bracket	40	S571360	M10 Nut
12	A217	M8 x 50 Bolt	41	S571410	M10 Nut Nyloc
13	S1091991	Shut-off handle	42	S998031	Packer
14	S720350	Handle spring	43	S552125	M10 x 70 Bolt
15	S573110	M10 Washer	44	S551860	M8 x 10 Bolt
16	S592201	R Clip	45	S993231	Agitator shaft
17	S992312	Sprocket axle (primary)	46	S1193143	Reflector bracket
18	S992157	Spacer	47	S720353	Red Reflector 40 x 30
19	S590306	Roll Pin M6 x 28	48	S720352	White Reflector 40 x 30
20	S993161	Sprocket 1 (primary axle)	49	S734001	Spacer
21	S590308	Roll Pin M6 x 40	50	S993199	Agitator shaft
22	S590106	Roll Pin M3.5 x 40	51	S992240	Spacer
23	S992373	Sprocket axle (primary)	52	S720351	Washer
24	S992061	Sprocket axle washer (primary)	53	S1091787	Splitter box chain guard
25	S720349	Sprocket axle spring	54		M8 x 100 Bolt
26	S996026	Key 6 x 6 x 35	55	S571208	M8 Nut
27	S1091055	Sprocket 1 (primary axle)	56	S594306	Lynch Pin
28	S992151	Sprocket insert 19 teeth	57	S715010	Lynch pin chain
29	S993177	Sprocket 24 teeth (primary axle)			

Parts list

Seedbox Metering Parts

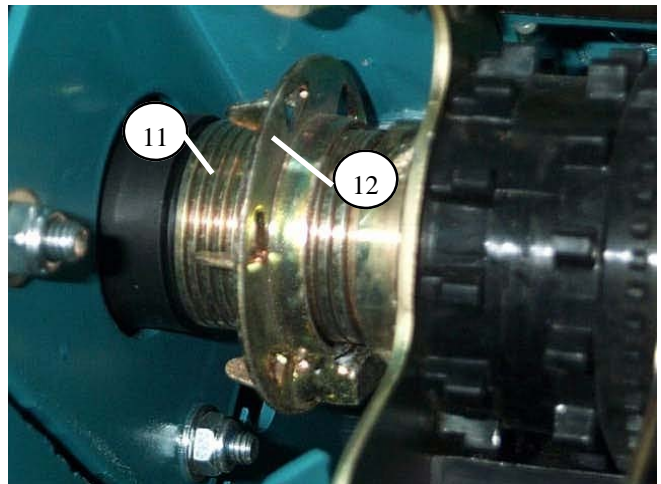
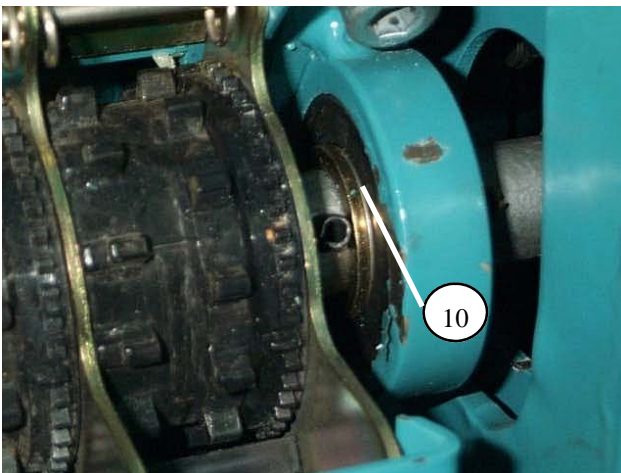
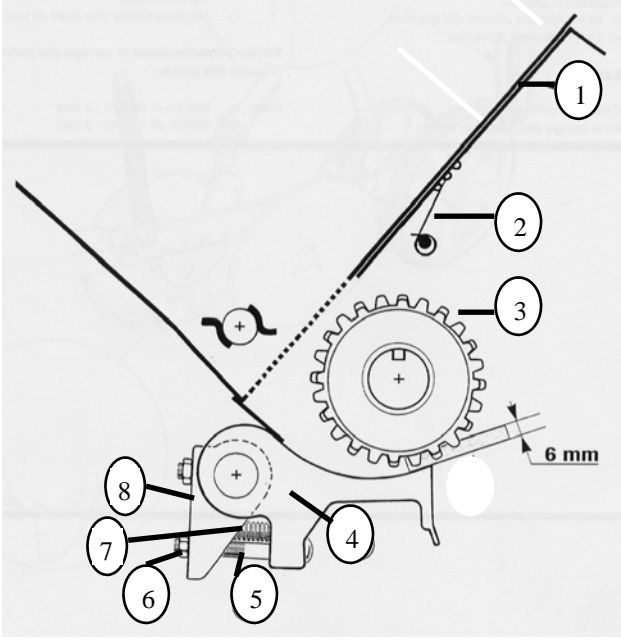

Parts list

Seedbox Metering Parts

ITEM	PART No	DESCRIPTION
<i>1</i>	S907381	Feed Trap Shutter
<i>2</i>	S909068	Feed Trap Spring
<i>3</i>	S901539	Standard Seed Wheel
	S901538	Fine Seed Wheel
<i>4</i>	S985209	Skid Flap
<i>5</i>	S525895	M8 X 45 Screw
<i>6</i>	S571806	M8 Nut
<i>7</i>	S909081	Skid Flap Spring
<i>8</i>	S904599	Skid Flap Support
<i>9</i>	S985210	Rape Shutter
<i>10</i>	S711008	Distribution Shaft Bearing
<i>11</i>	S909083	Clutch Spring
<i>12</i>	S923067	Clutch Spring Retainer

Parts list

Seedbox Assembly

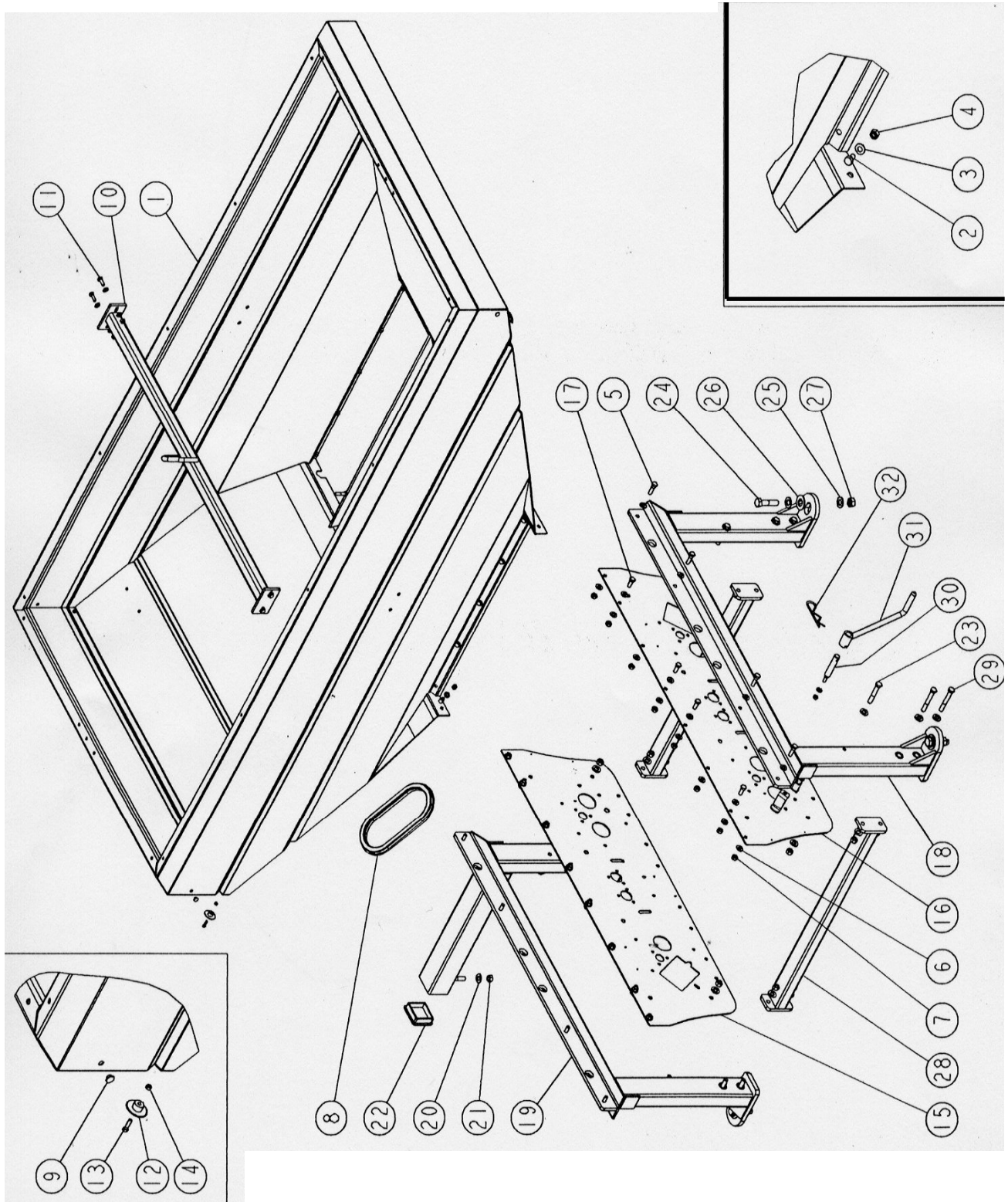

Parts list

Seedbox Assembly

Item	Part No	Description	Item	Part No	Description
<i>1</i>	S1191045	Seed Hopper	<i>17</i>	S552076	M10 x 25 Bolt
<i>2</i>	S551865	M8 x 15 Bolt	<i>18</i>	S1191000	Rear Frame
<i>3</i>	S573158	M8 Washer	<i>19</i>	S1191001	Front Frame
<i>4</i>	S571208	M8 Nut	<i>20</i>	S573112	M12 Washer
<i>5</i>	S552085	M10 x 35 Bolt	<i>21</i>	S571212	M12 Nut
<i>6</i>	S573110	M10 Washer	<i>22</i>	S720158	Plastic End Plate 80 x 80
<i>7</i>	S571210	M10 Nut	<i>23</i>	S552297	M12 x 70 Bolt
<i>8</i>	S908381	Sight Glass	<i>24</i>	S552720	M16 x 70 Bolt
<i>9</i>	S415716	Plastic Cork.	<i>25</i>	S573166	M16 Washer
<i>10</i>	S1191046	Strengthening Beam	<i>26</i>	S573172	M22 Washer
<i>11</i>	S551875	M8 x 25 Bolt	<i>27</i>	S571416	M16 Nut Nyloc
<i>12</i>	S720347	Cover strap holder	<i>28</i>	S1191390	Side Strengthening Beam
<i>13</i>		M5 X 20 Bolt	<i>29</i>	S552298	M12 x 80 Bolt
<i>14</i>	S571205	M5 Nut	<i>30</i>	S1091612	Crank Support
<i>15</i>	S997620	Lower End Plate - Front	<i>31</i>	S916148	Crank
<i>16</i>	S1191016	Lower End Plate - Rear	<i>32</i>	S592202	R Clip

Parts list

Seedbox Hopper Extension

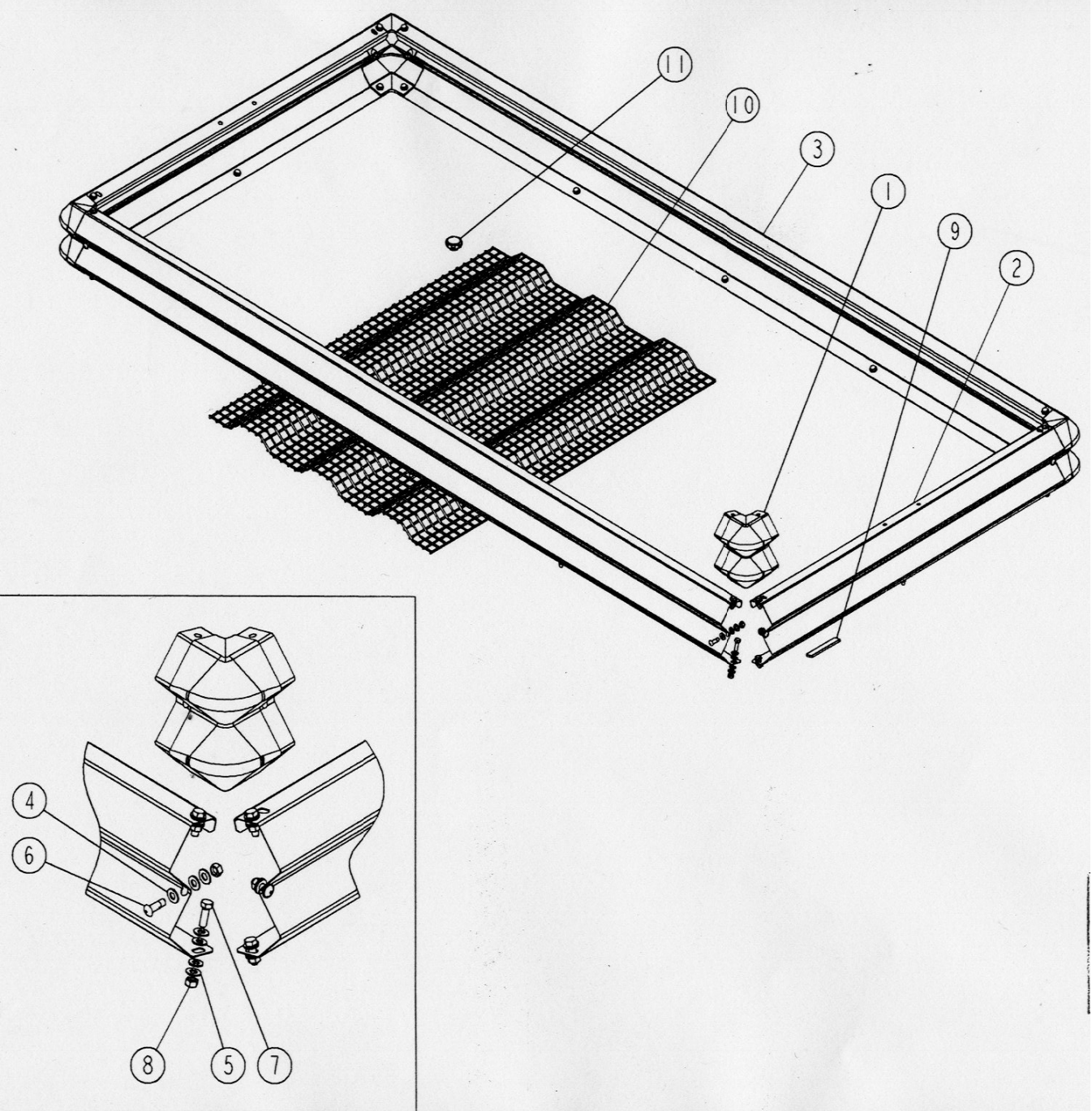

Parts list

Seedbox Hopper Extension

ITEM	PART No	DESCRIPTION
<i>1</i>	S973045	Double Corner Bracket
<i>2</i>	S997618	Short Side Extension
<i>3</i>	S997617	Long Side Extension
<i>4</i>	S573008	M8 Nylon Washer
<i>5</i>	S573808	M8 Washer
<i>6</i>	S555825	M8 x 25 Bolt
<i>7</i>	S558825	M8 x 25 Bolt
<i>8</i>	S571408	M8 Nut Nyloc
<i>9</i>	S794021	Adhesive Strip
<i>10</i>	S998183	Sieve
<i>11</i>	S900010	Plastic Handle with M8 Nut

Parts list

Seedbox Hopper Cover

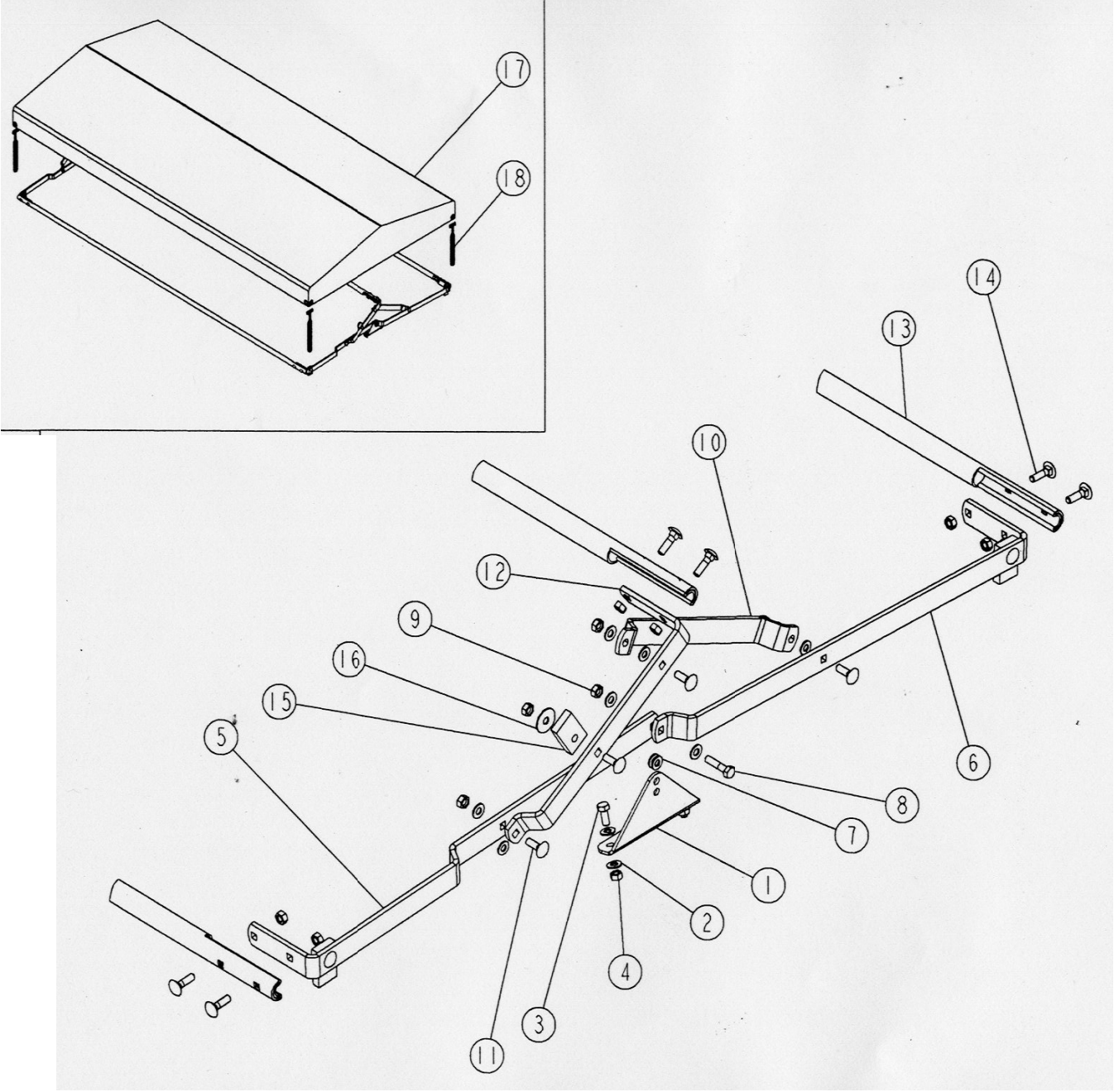

Parts list

Seedbox Hopper Cover

ITEM	PART No	DESCRIPTION
<i>1</i>	S967107	Cover Bracket
<i>2</i>	S573808	M8 Washer
<i>3</i>	S551770	M8 x 20 Bolt
<i>4</i>	S571258	M8 Nut
<i>5</i>	S994242	End Brace 1
<i>6</i>	S994343	End Brace 2
<i>7</i>	S573008	Nylon Washer
<i>8</i>	S558835	M8 x 35 Bolt
<i>9</i>	S571408	M8 Nut Nyloc
<i>10</i>	S942057	End Brace 3
<i>11</i>	S558925	M8 x 25 Bolt Cup Square
<i>12</i>	S942059	End Brace 4
<i>13</i>	S994241	Tube Brace
<i>14</i>	S558930	M8 x 30 Bolt Cup Square
<i>15</i>	S987719	Rubber Block
<i>16</i>	S573358	Washer M8
<i>17</i>	S998205	Hopper Cover
<i>18</i>	S696110	Rubber Strap

Parts list

PTO Fan Parts

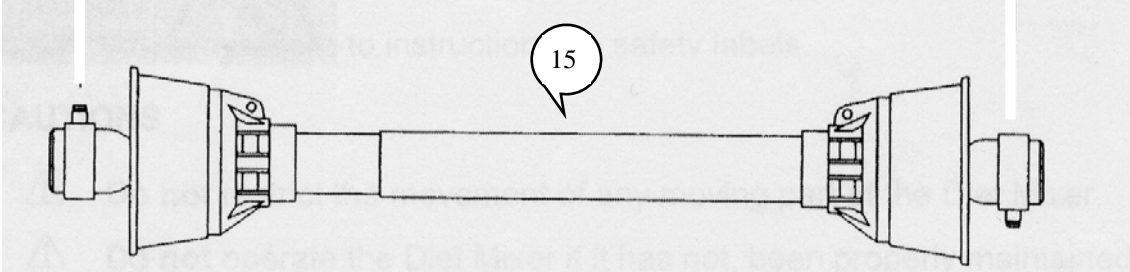
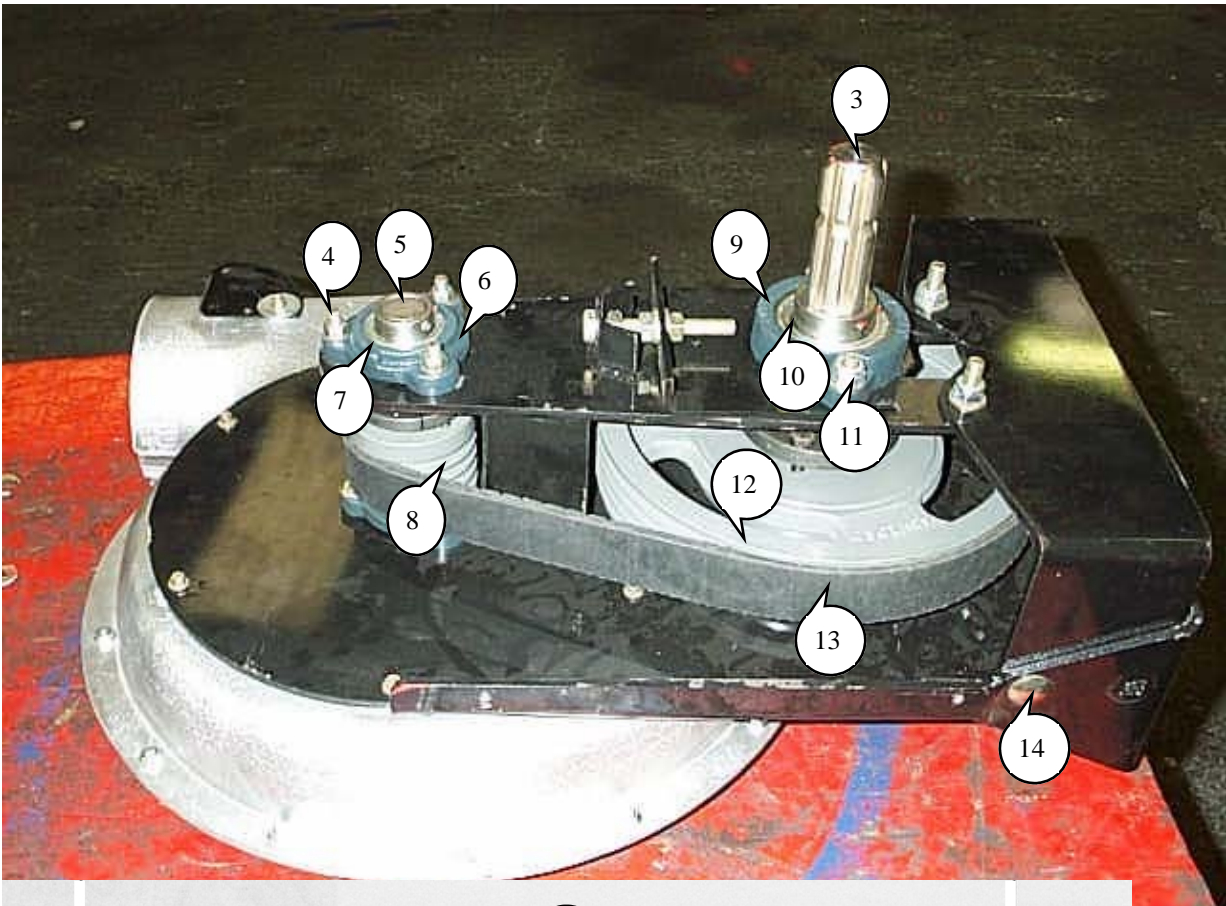
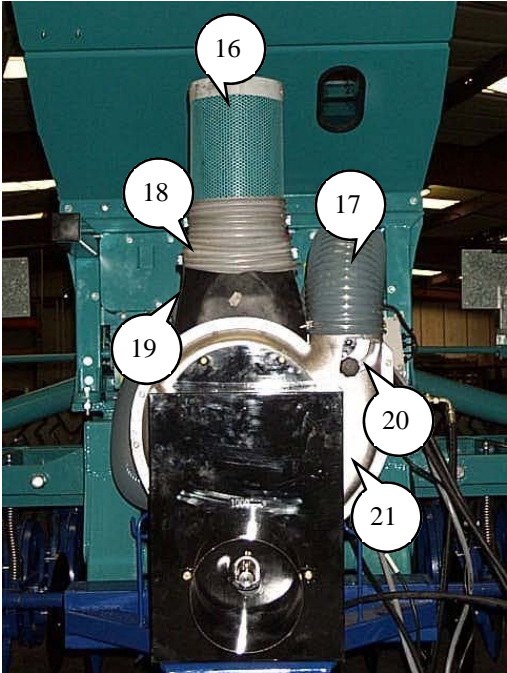
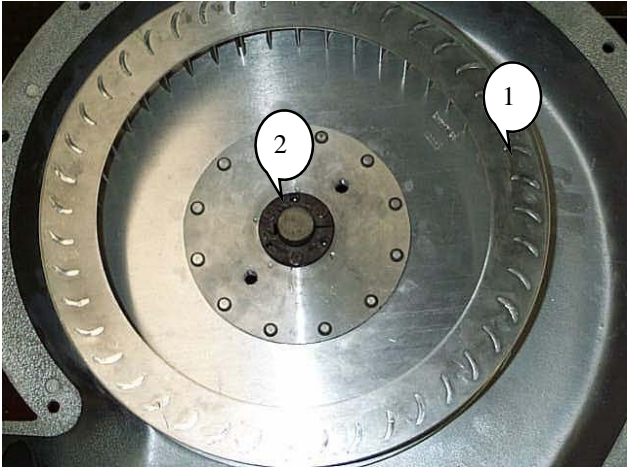

Parts list

PTO Fan Parts

ITEM	PART No	DESCRIPTION
<i>1</i>	PTO - 01	Propeller
<i>2</i>	PTO - 02	Taperlock
<i>3</i>	PTO - 03	PTO Axle
<i>4</i>	PTO - 04	Fan shaft bearing carrier bolt
<i>5</i>	PTO - 05	Fan shaft
<i>6</i>	PTO - 06	Fan shaft bearing carrier
<i>7</i>	PTO - 07	Fan shaft bearing
<i>8</i>	PTO - 08	Fan shaft pulley wheel
<i>9</i>	PTO - 09	PTO shaft bearing carrier
<i>10</i>	PTO - 10	PTO shaft bearing
<i>11</i>	PTO - 11	PTO shaft bearing carrier bolt
<i>12</i>	PTO - 12	PTO shaft pulley wheel
<i>13</i>	PTO - 13	Fan Belt
<i>14</i>	PTO - 14	Mounting bolt cup square.
<i>15</i>	PTO - 15	PTO Drive Shaft
<i>16</i>	PTO - 16	Air filter
<i>17</i>	PTO - 17	Air hose
<i>18</i>	PTO - 18	Air hose clip
<i>19</i>	PTO - 19	Air funnel
<i>20</i>	PTO - 20	Air deflector
<i>21</i>	PTO - 21	Fan Housing

Parts list

Hydraulic Fan Parts

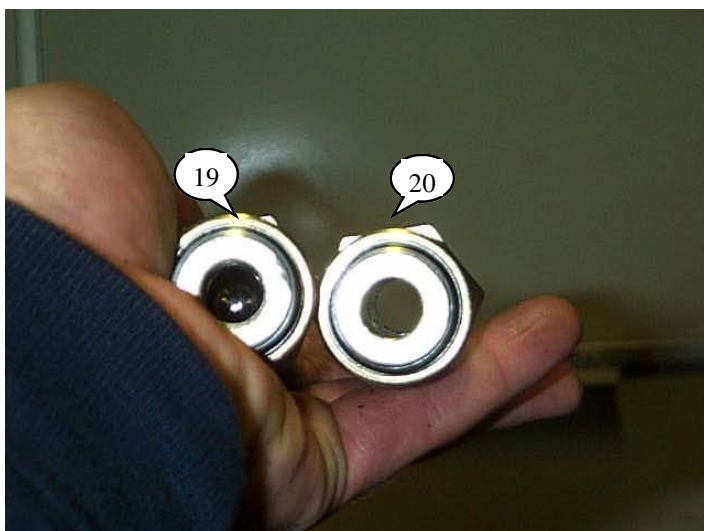
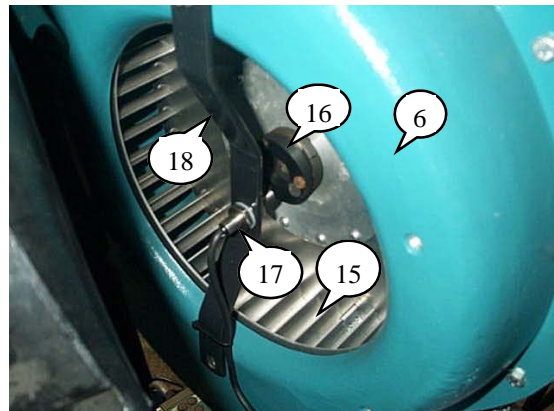
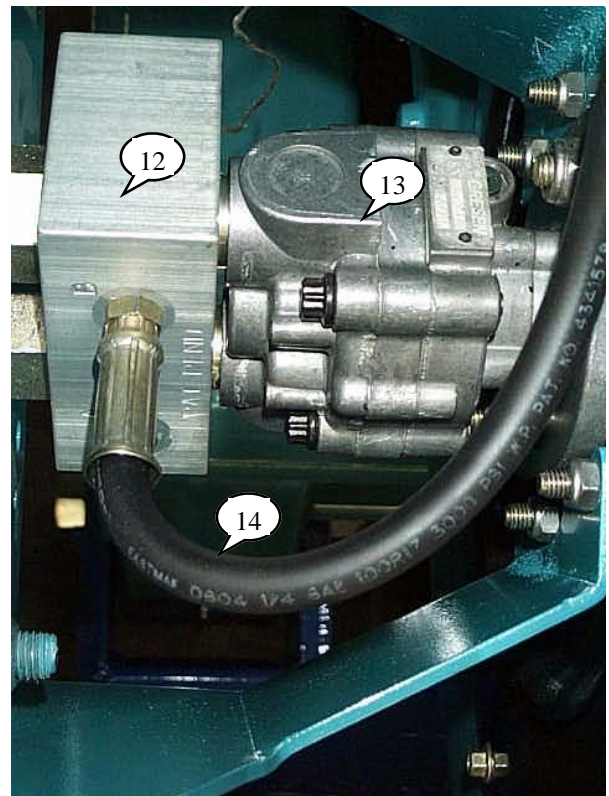
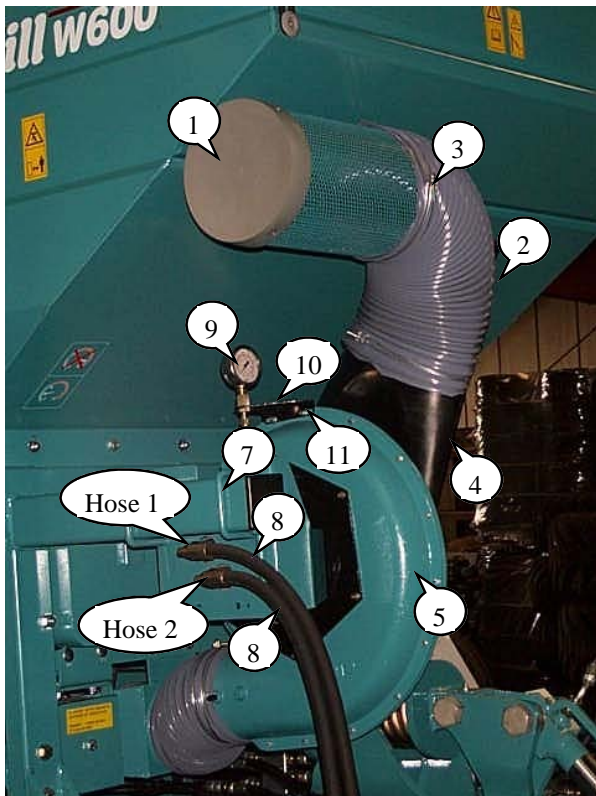

Optional Equipment

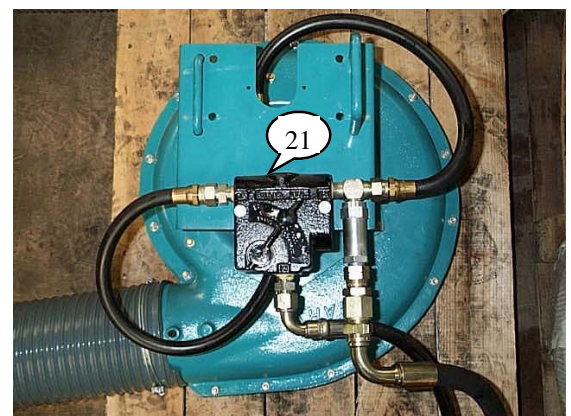

Parts list

Hydraulic Fan Parts

ITEM	PART No	DESCRIPTION
<i>1</i>	HF - 01	Air Filter
<i>2</i>	HF - 02	Air Hose
<i>3</i>	HF - 03	Air Hose Clip
<i>4</i>	HF - 04	Air Funnel
<i>5</i>	HF - 05	Inner Plate
<i>6</i>	HF - 06	Outer Plate
<i>7</i>	HF - 07	M12 U Bolts, Washer & Nut
<i>8</i>	HF - 08	1" Hoses
<i>9</i>	HF - 09	Manometer Clock
<i>10</i>	HF - 10	Manometer mounting plate
<i>11</i>	HF - 11	Mounting plate screws M5 x 20
<i>12</i>	HF - 12	Hydraulic Motor
<i>13</i>	HF - 13	Aluminium probe block
<i>14</i>	HF - 14	1/4" Hose
<i>15</i>	HF - 15	Propeller
<i>16</i>	HF - 16	Taper Lock
<i>17</i>	HF - 17	Propeller speed sensor
<i>18</i>	HF - 18	Sensor mounting bar
<i>19</i>	HF - 19	1" Ball Valve Probe. Hose 1
<i>20</i>	HF - 20	1" Standard Probe. Hose 2
<i>21</i>	HF - 21	Flow control system

Parts list

Rear Platform

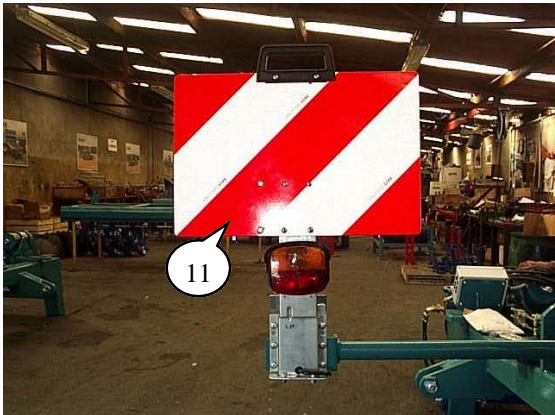
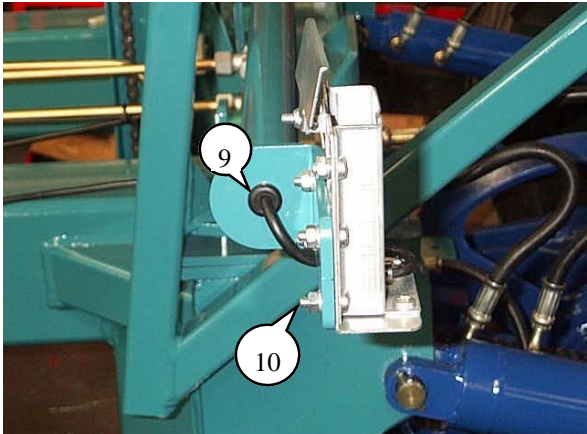

Parts list

Rear Platform

ITEM	PART No	DESCRIPTION
1	W6.500A	Rear platform Complete
2	W6.524	Safedeck
3	A118B	M10 x 60 Bolt
	A118W	M10 Washer
	A139	M10 Nyloc Nut
4	W6.501A	Ladder-Bottom Half
5	A107	M16 x 50 Bolt
	A137	M16 Nyloc Nut
6	W6.501CP	Pin and Chain
7	A107	M16 x 50 Bolt
	A137	M16 Nyloc Nut
8	A232LB	Lights / Indicator Bracket
9	11691	Plastic Grommit
10	A125	M5 x 20 Bolt
	A141	M5 Nut
11	A232	Geka lights and reflective board

Parts list

Moore Solo Marker Complete



Parts list

Moore Solo Marker Complete

ITEM	PART No	DESCRIPTION	ITEM	PART No	DESCRIPTION
1	SM-03A	Main Marker Arm	17	SM - 12A	Break off pin
2	SM-06A	Outer Marker Arm	18	A246	Shear Bolt M10 X 100
3	SPI - 01	Moore Solo Marker Ram	19	SM - 07A	Main Marker Pin
4	S720174	Retractor Cable	20	SM - 10A	Disc Mounting Arm
5	SM-02A	Marker Swivel Bracket	21	SM - 08A	Dished Disc hub Assembly
6	A102	Marker Swivel Bracket Bolt 3/4 X 4x1/2 UNC	22	A160D	Dished Disc
7	A107	Marker Ram Pivot Bolt M16 X 50	23	A182	Dust Cap - Small
	A137	M16 Nyloc Nut	24	A254	M16 X 40 Setscrew
8	KP5058-KP	Rubber Buffer 75 X 89	25	A111	M12 X 55 Bolt
9	A138	Nut M12 Nyloc		A138	Nut M12 Nyloc
10	A182	Dust Cap - Small	26	S996321	Buffer Support Bracket
11	SM - 26	Ram - Slot Bush	27	A214	M10 X 80 Bolt
12	A210	Ram Bolt M16 X 45		A139	Nut M10 Nyloc
13	A174	M16 Spring Washer	28	S1 091 542	Bottom Buffer Bracket
14	SM - 31	Ram Mounting Boss	29	S793704	Rubber Buffer
15	SM - 09A	Retractor Assembly	30	A139	Nut M10 Nyloc
16	SM - 05A	Solo Marker Knuckle			

Parts list

SPI Solo Marker Complete

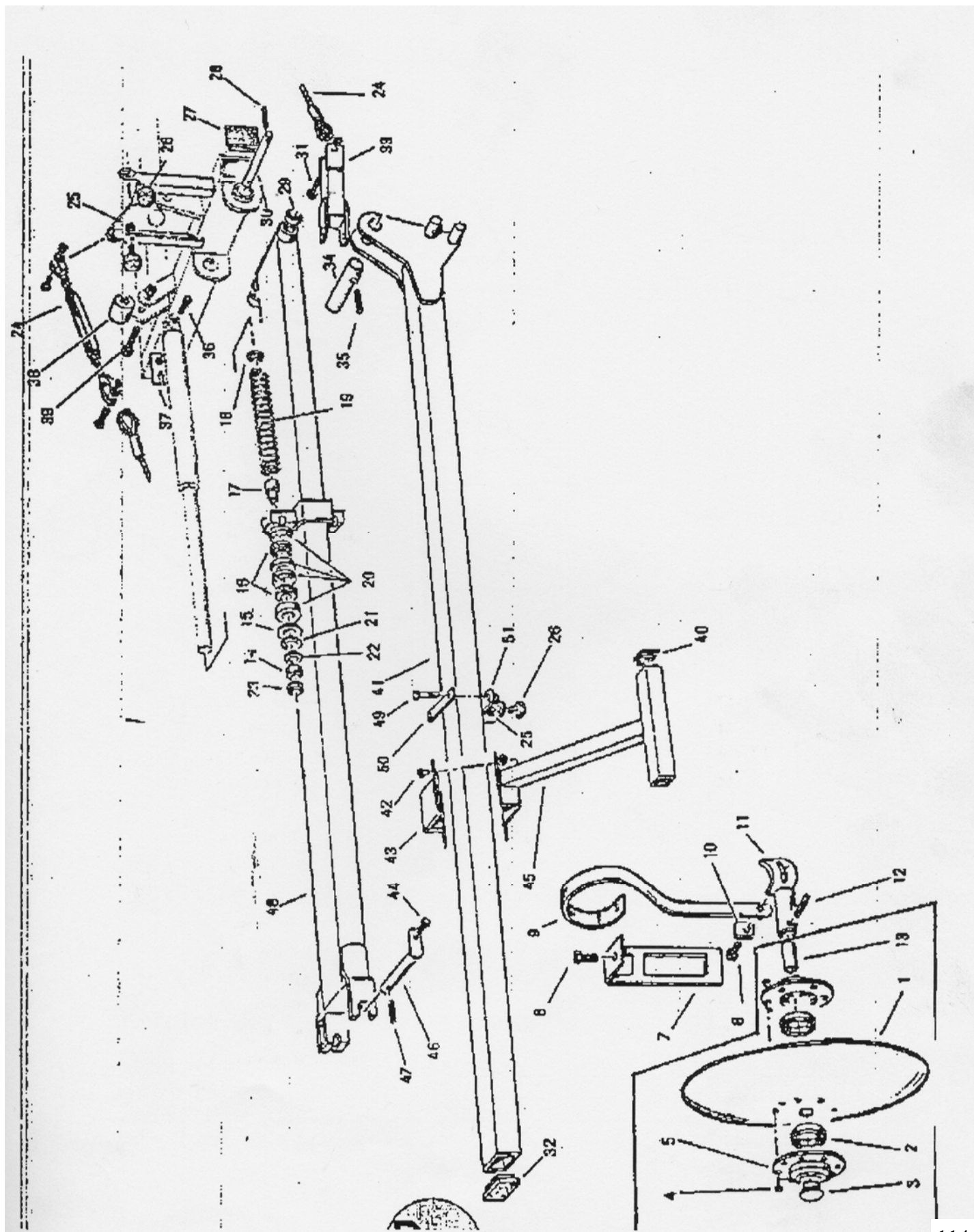

Parts list

SPI Solo Marker Complete

ITEM	PART No	DESCRIPTION	ITEM	PART No	DESCRIPTION
1	S980102	Dished Disc	29	S415722	Bushen 100 X 50
2	S711000	Bearing 6204 2 RS	30	S992324	Main Marker axle
3	S415717	End Cap GPN 910	31	S554250	Bolt CHc 12 X 55
4	S551666	Bolt H6 X 16 Zn		S571462	Nut H12
	S571406	Nut H6 Zn	32	S415722	End Cap 100 X 50
5	S908360	Dished disc Hub	33	S1 091 517	Cable Swivel Bracket
6	S554250	Bolt CHc 12 X 55	34	S992323	Cable Swivel pin
	S571462	Nut H12 Zn	35	S590307	Roll Pin 6 X 35
7	S916049	Marker Holder	36	S554250	Bolt CHc 12 X 55
8	S552125	Bolt H10 X 70 Zn		S571462	Nut H12 Zn
9	S980003	Spring Tine	37	S962071	Pin Lock
10	S963025	Packer Washer	38	S998149	Nylon Roller
11	S914011	Disc axle bracket	39	S554250	Bolt CHc 12 X 55
12	S590307	Roll Pin 6 X 35		S571462	Nut H12 Zn
13	S921017	Dished Disc Axle	40	S720175	End Cap 40 X 40
14	S571216	Nut H16 Zn	41	S1 091 516	Secondary Marker Arm
15	S573166	Washer M16 N Zn	42	S571462	Nut H12 Zn
16	S981801	Damping Mechanism		S720175	End Cap 40 X 40
17	S964064	Guide Bar	43	S996319	Support Bracket
18	S985009	Spring Collar	44	S554250	Bolt CHc 12 X 55
19	S981302	Compression Spring	45	S1 091 403	Disc Support Arm
20	S573905	Damper Washers	46	S914001	Elbow Pin
21	S573170	Washer M20 N Zn	47	S571307	Roll Pin 6 X 35
22	S573166	Washer M16 N Zn	48	S1 091 515	Main Marker Arm
23	S571366	Lock Nut Hm 16	49	S554250	Bolt CHc 12 X 55
24	S720174	Retractor Cable Complete		S571462	Nut H12 Zn
25	S571206	Nut H6	50	S996321	Buffer Support Bracket
26	S793704	Rubber Buffer	51	S1 091 542	Bottom Buffer Bracket
27	S720158	End Cap 80 X 80	52	SPIs 001	Marker Ram
28	S590307	Roll Pin 6 X 35			

Parts list

Pre Emergence Marker

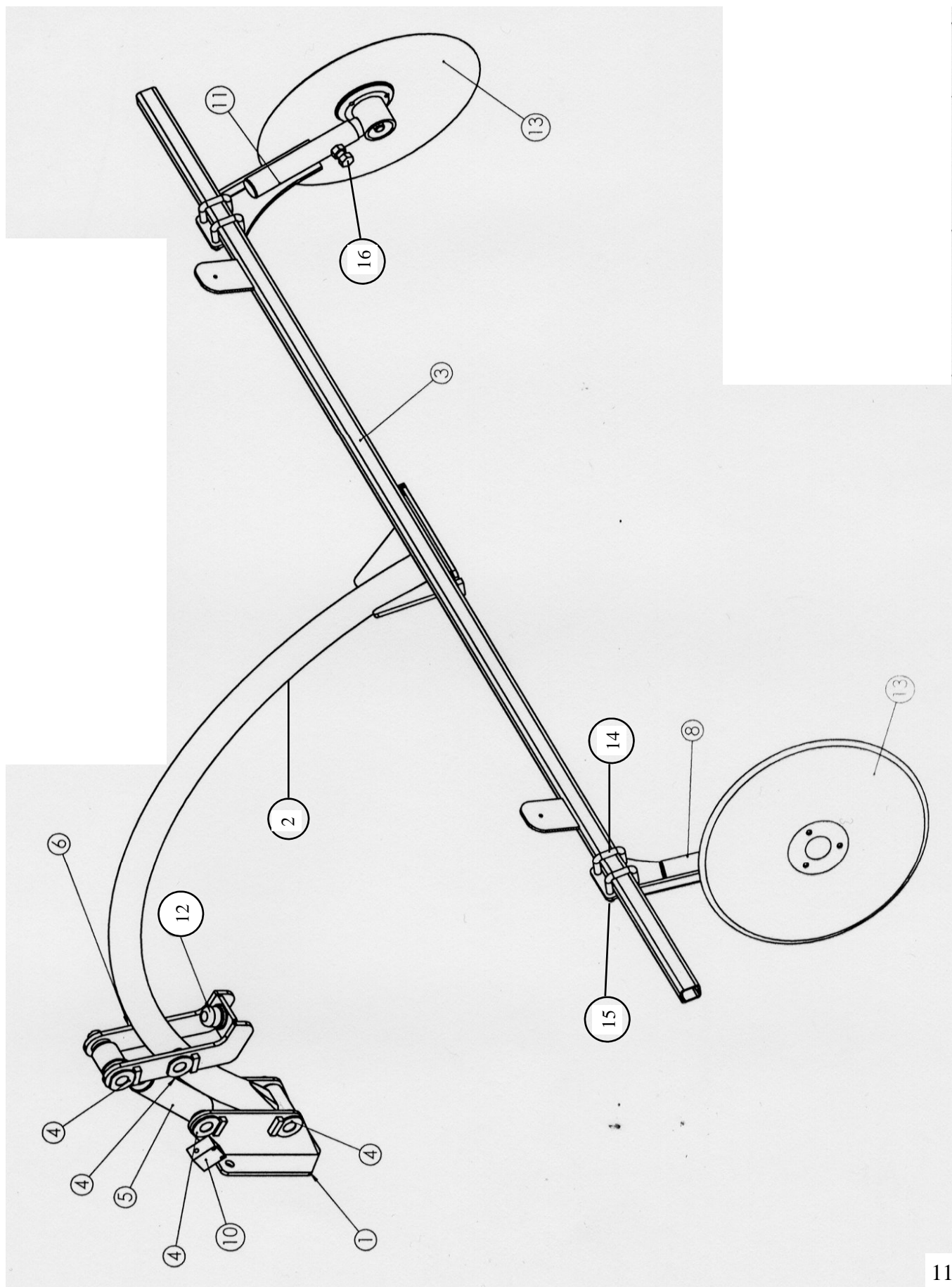

Parts list

Pre Emergence Marker

Item Number	Part Number	Description
<i>1</i>	WPM 1.1A	Pre Emergence Marker Bracket
<i>2</i>	WPM 1.2A	Main Tube
<i>3</i>	WPM 1.3A	Disc Mounting Bar
<i>4</i>	A103N	Pivot Arm Bolt
	A251	1" Binx nut
<i>5</i>	BAC398	Pre Emergence Ram
<i>6</i>	WPM 1.4A	Rocker Buffer
<i>8</i>	WPM 1.5A	Disc Mounting Arm
<i>10</i>	BY 01A	2 Way Valve 3/8"
<i>11</i>	WPM 1.13	Disc Assembly Bracket
<i>12</i>	KP 5058-KP	Rubber Buffer (50 / 58)
	A139	M10 Nyloc
<i>13</i>	SM - 08A	Disc Assembly
<i>14</i>	RTC - 01	U Bolt
<i>15</i>	A138	U Bolt Nut
<i>16</i>	A254	M16 x 20 Setscrew

Parts list

4M & 6M Hydraulic Hoses and Fittings

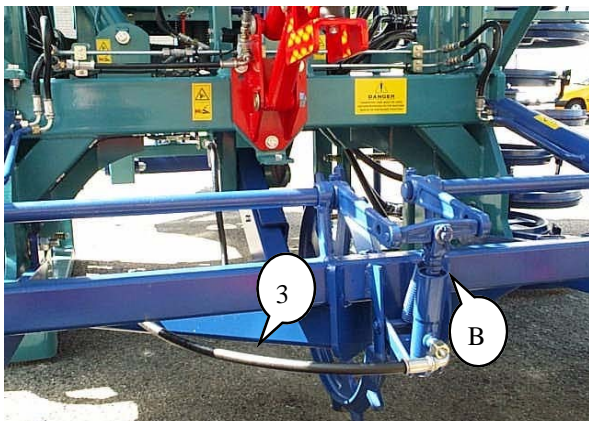
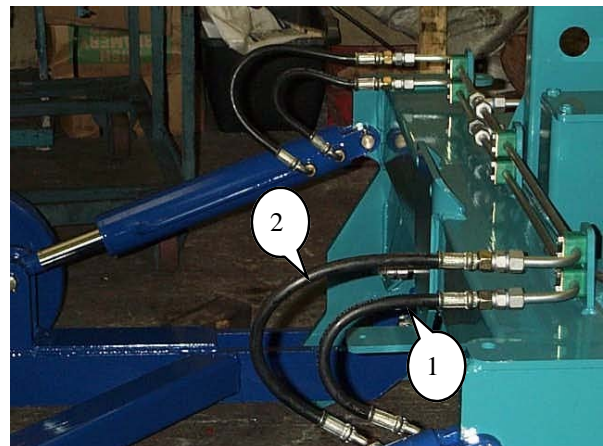
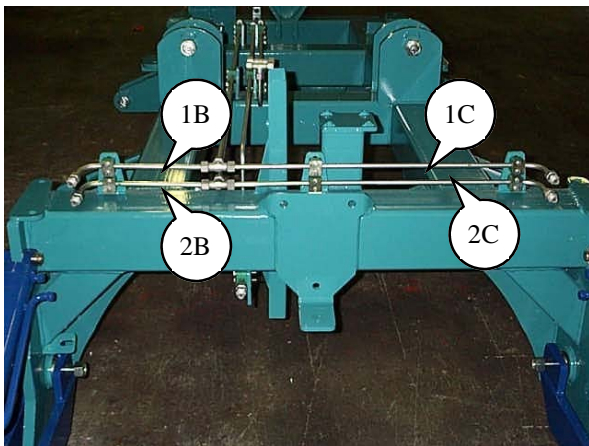
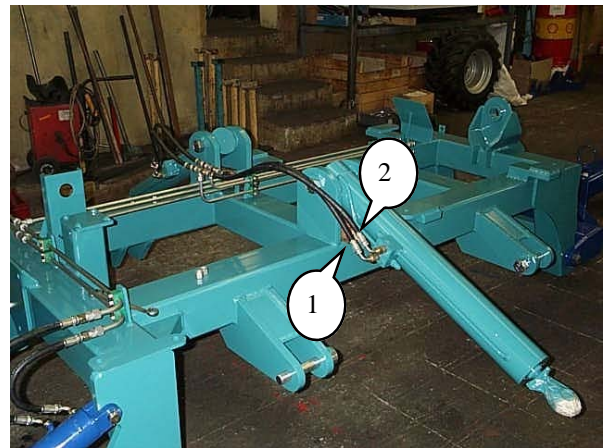
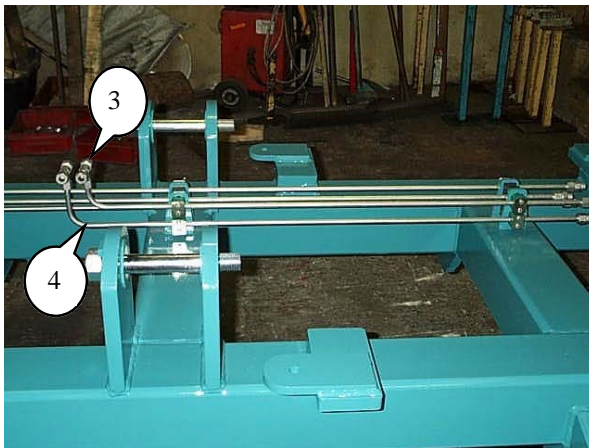
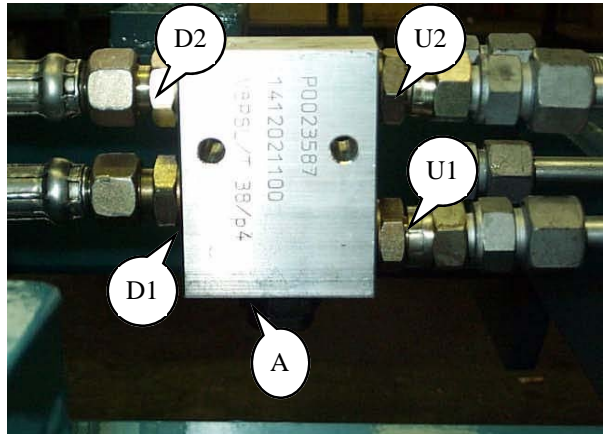
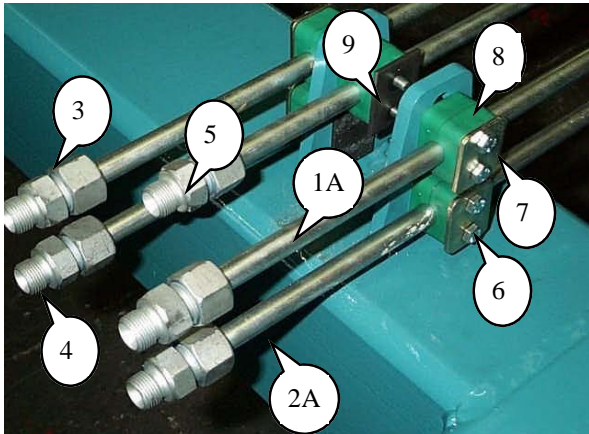

Parts list

4M & 6M Hydraulic Hoses and Fittings

Pipe Type And No.	Pipe Part No	End 1 (Left)	Fitting Part No	End 2 (Right)	Fitting Part No	Description
Steel 1A	W600SP-1A	1/2" x 3/8" BSP Straight	HABB0608	1/2" x 1/2" x 1/2" BSP Tee	TEE08	Rear Axle Ram inlet pipe Centre
Steel 1B	W600SP-1B	1/2" x 3/8" BSP Straight	HABB0608	1/2" x 1/2" x 1/2" BSP Tee	TEE08	Rear Axle Ram Left inlet pipe
Steel 1C	W600SP-1C	1/2" x 1/2" x 1/2" BSP Tee	TEE08	1/2" x 3/8" BSP Straight	HABB0608	Rear Axle Ram Right inlet pipe
Steel 2A	W600SP-2A	1/2" x 3/8" BSP Straight	HABB0608	1/2" x 1/2" x 1/2" BSP Tee	TEE08	Rear Axle Ram Return pipe Centre
Steel 2B	W600SP-2B	1/2" x 3/8" BSP Straight	HABB0608	1/2" x 1/2" x 1/2" BSP Tee	TEE08	Rear Axle Ram Left Return pipe
Steel 2C	W600SP-2C	1/2" x 1/2" x 1/2" BSP Tee	TEE08	1/2" x 3/8" BSP Straight	HABB0608	Rear Axle Ram Right Return Pipe
Steel 3	W600SP-3	1/2" x 3/8" BSP Straight	HABB0608	1/2" x 1/2" x 1/2" BSP Tee	TEE08	Wing ram inlet Pipe
Steel 4	W600SP-4	1/2" x 3/8" BSP Straight	HABB0608	1/2" x 1/2" x 1/2" BSP Tee	TEE08	Wing ram return Pipe
Steel 5	W600SP-5	1/2" x 3/8" BSP Straight	HABB0608	1/2" x 3/8" BSP Straight	HABB0608	Hydraulic Brake Pipe
Rubber 1	HW600WK-1	3/8" Female 90' Hose end	HA06A06NU90	3/8" Female Straight end	HA06A06NU	Wing ram Inlet Hose
Rubber 2	HW600WK-2	3/8" Female 90' Hose end	HA06A06NU90	3/8" Female Straight end	HA06A06NU	Wing ram Return hose
Rubber 1	HW600RAK-1	3/8" Female Straight end	HA06A06NU	3/8" Female 90' Hose end	HA06A06NU90	Rear Axle Ram Inlet Hose
Rubber 2	HW600RAK-2	3/8" Female Straight end	HA06A06NU	3/8" Female 90' Hose end	HA06A06NU90	Rear Axle Ram Return Hose
Rubber 3	HW600HBH-3	3/8" Female Straight end	HA06A06NU	3/8" Female 90' Hose end	HA06A06NU90	Hydraulic Brake Rear Hose

Single Acting Check Valve (A)

Fitting Number	Fitting Type	Part Number
U1	3/8" Male x 3/8" Female Straight	HABBS0606
U2	3/8" Male x 3/8" Female Straight	HABBS0606
D1	3/8" Male x 3/8" Male Straight	HABB0606
D2	3/8" Male x 3/8" Male Straight	HABB0606

Hydraulic Brakes

Item No:	Part No	Description
B	A167DR	Hydraulic brake ram

Steel Pipe Holders

Item No:	Part No:	Description
6	HRL1 - ASKT	M6 x 40 Bolt
7	HRL1 - DP	Top Plate
8	HRL1 - KP12PP	Plastic Clamp Body
9	HRL1 - AP	Base Plate

Parts list

Moore Expert Hydraulic Hoses and Fittings

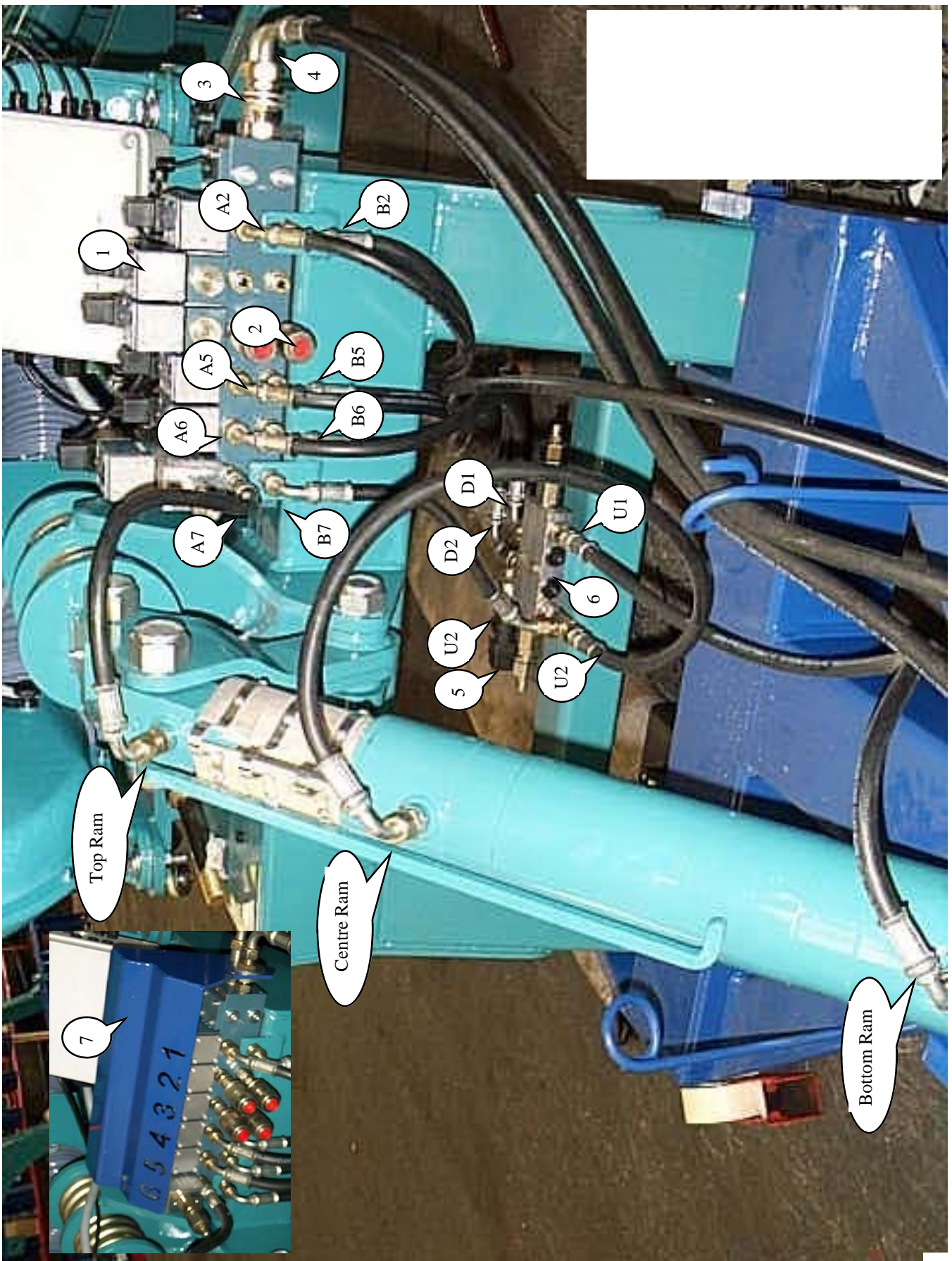

Parts list

Moore Expert Hydraulic Hoses and Fittings

Pipe Type And No.	Pipe Part No	End 1 (Left)	Fitting Part No	End 2 (Right)	Fitting Part No	Description
Rubber A2 to D1	HHW600E1 3/8	3/8" Female Hose End	HA06A06NU	3/8" Female 45' Hose End	HA06A06NU45	A2 to D1 870mm
Rubber B2 to D2	HHW600E2 3/8	3/8" Female Hose End	HA06A06NU	3/8" Female 90' Hose End	HA06A06NU90	B2 to D2 810mm
Rubber A5 to Top Wing Steel Pipe	HHW600E3 3/8	3/8" Female Hose end	HA06A06NU	3/8" Female 45' Hose End	HA06A06NU45	A5 to Top Wing Steel Pipe. 910mm
Rubber B5 to Bottom Wing Steel Pipe	HHW600E4 3/8	3/8" Female Hose End	HA06A06NU	3/8" Female 90' Hose End	HA06A06NU90	B5 to Bottom Wing Steel Pipe 780mm
Rubber A6 to D1. Dual Over Centre Valve	HHW600E5 3/8	3/8" Female 90' Hose End	HA06A06NU90	3/8" Female 45' Hose End	HA06A06NU45	A6 to D1 Dual Over Centre Valve 540mm
Rubber B6 to D2. Dual Over Centre Valve	HHW600E6 3/8	3/8" Female 90' Hose End	HA06A06NU90	3/8" Female 90' Hose End	HA06A06NU90	B6 to D2 Dual Over Centre Valve 510mm
Rubber A7 to Top ram	HHW600E7 3/8	3/8" Female Hose End	HA06A06NU	3/8" Female 90' Hose End	HA06A06NU90	A7 to Top ram 480mm
Rubber B7 to U2. Dual Over Centre Valve	HHW600E8 3/8	3/8" Female 90' Hose End	HA06A06NU90	3/8" Female 45' Hose End	HA06A06NU45	B7 to U2 Dual Over Centre Valve 290mm
Rubber U1 to Bottom Drawbar Ram	HHW600E9 3/8	3/8" Female Hose End	HA06A06NU	3/8" Female 90' Hose End	HA06A06NU90	U1 to Bottom Drawbar Ram 910mm
Rubber U2 to Centre Drawbar Ram	HHW600E10 3/8	3/8" Female Hose End	HA06A06NU	3/8" Female 90' Hose End	HA06A06NU90	U1 to Centre Drawbar Ram 940mm

Hydraulic Ram Seal Kits

Description	Part Number
Drawbar Ram Seal Kit	BAC093SK
Rear Axle Ram Seal Kit	BAC358SK
Wing Ram Seal Kit	BAC808SK
Sulky Marker Ram Seal Kit	S982301SK
SPI Solo Marker Ram Seal Kit	SPI - 01SK

Additional Components

Item No	Part Number	Description
1	LC1XB13CSN	CETOP Valves
2	VSRU14	Inline Flow control Valve 3/8"
3	HABB0808	1/2" Male Straight
4	HA08A08MU	1/2" Female Hose End 90'
5	CEL08	Pressure Switch
6	W6.262V	Dual Over Centre Valve
7	W6.800A	Expert solenoid cover plate

Parts list

Electrical Parts - Chassis



Parts list

Electrical Parts - Chassis

Item Number	Part Number	Description
<i>1</i>	S983606	Moore Expert Control Pod
<i>2</i>	RDS - 01	Wire and Signal Harness (37 Pin Plug)
<i>3</i>	RDS - 02	Power Lead to Moore Expert Junction Box
<i>4</i>	S983802	Power Lead to RDS Pod (EuroPlug)
<i>5</i>	A244B	RDS Moore Expert Junction Box
<i>6</i>	S951193	RDS Control Pod Mounting Bracket.
	A238	RDS Moore Expert Drill Control Complete Kit
<i>7</i>	W6.253L	Lights / Indicator Lead
<i>8</i>	A232	Geka Lights and Reflective Board
<i>9</i>	A201	Linak Actuator
<i>10</i>	A122	M10 x 25 Setscrew
<i>11</i>	A201B	Linak Actuator - mounting bracket

Parts list

Electrical Parts - Sensors

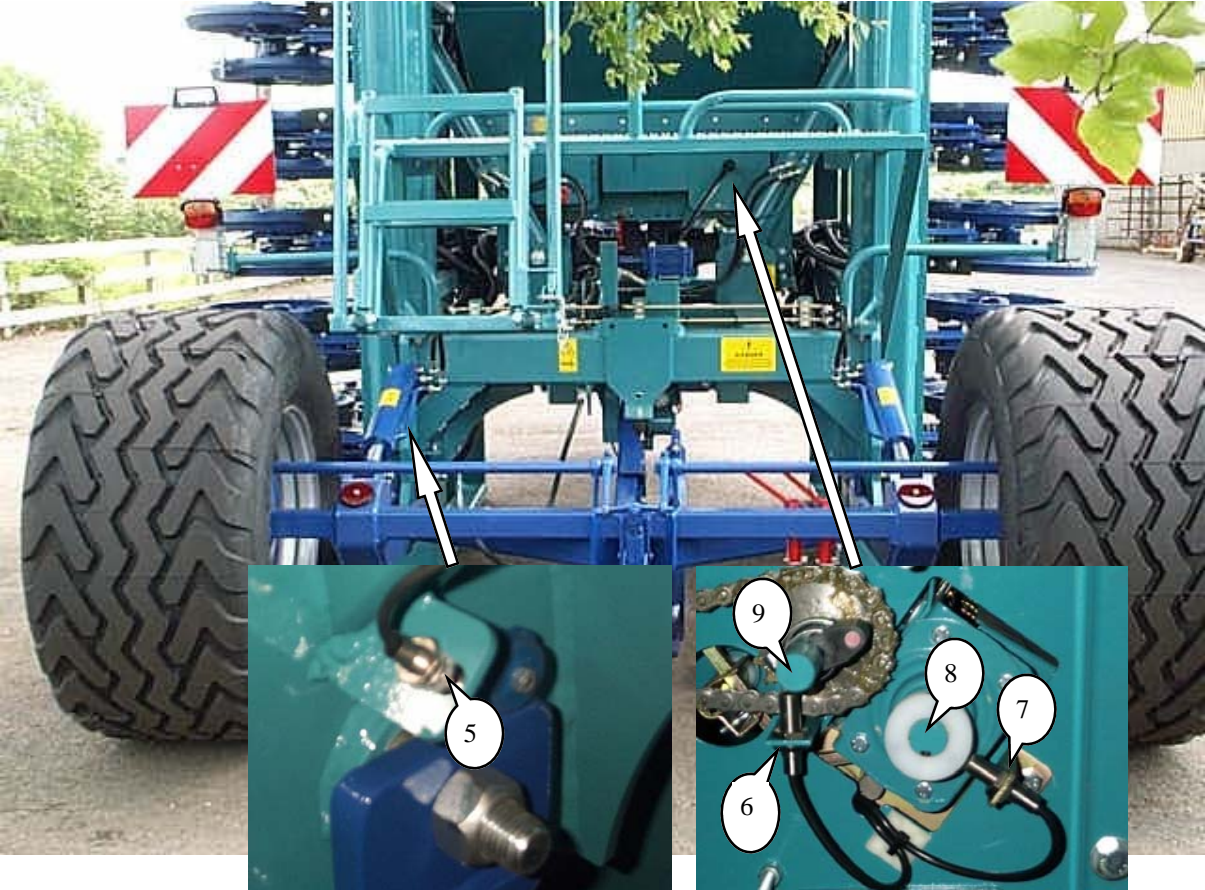
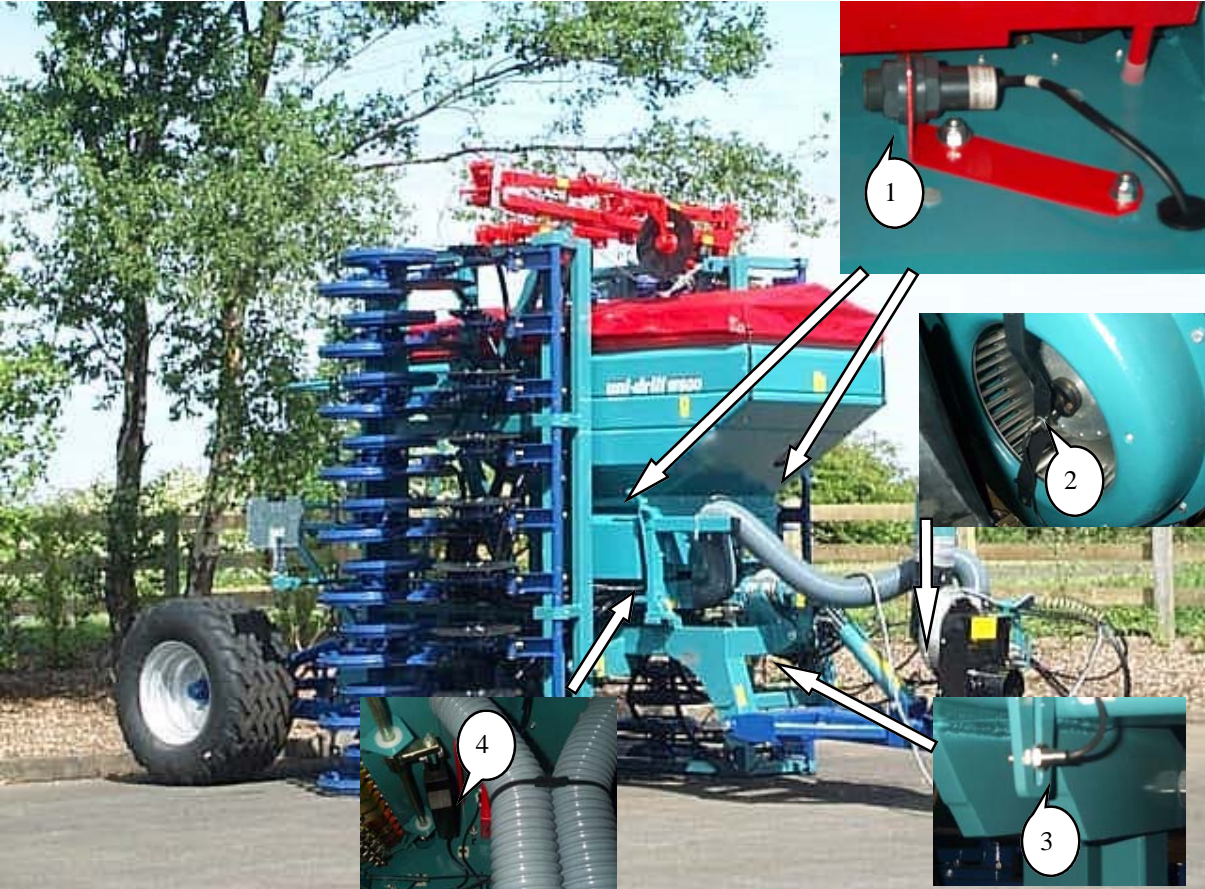

Parts list

Electrical Parts - Sensors

Item Number	Part Number	Description
<i>1</i>	S983913	Low Level Hopper Sensor
<i>2</i>	S983918	Fan Speed Sensor
<i>3</i>	S983917	Wing Fold Sensor
<i>4</i>	A201	Linak Actuator
<i>5</i>	S983912	Transport Wheel Sensor
<i>6</i>	S983915	Forward Speed/Area Sensor
<i>7</i>	S983916	Distribution Shaft Sensor
<i>8</i>	S711008S	Distribution Shaft
<i>9</i>	S720176S	Agitator Shaft

1



2



3



4

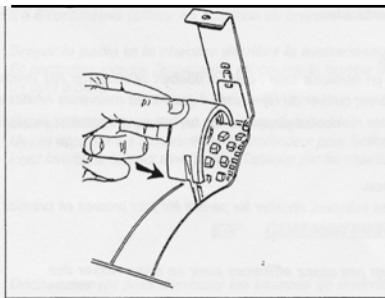

5



The calibration charts are only stated for information purposes only. Check your spreading rate per hectare for greater precision.

CALIBRATION CHARTS

A) Available Preset Reminders





1. Shutters (3 Positions)
2. Base Flap (6 Positions)
3. Air Flow Regulator (5 Positions)
4. Peg Wheels (2 Positions)
5. Variator (Markers 0 to 90)

B) Calibration Charts

- * Wheat 128
- * Rape, Barley, Peas and Beans 129
- * Oat, Mustard, Phacelia and Radish 130
- * Lucern, Linseed, Rye-grass and Clover. 131

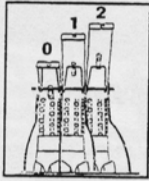
Calibration Charts

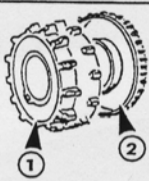
Shutter Opening Base Flap Position Peg Wheel Selection Air Flow Regulator

				
Colza Rape Raps	1	1	2	3
Luzerne Lucern Luzerne	1	1	1	3
Ray grass Rye grass Ray gras	1	1	1	3
Blé Wheat Weizen	2	1	1	4
Orge Barley Gerste	2	1	1	4
Pois Peas Erbсен	2	5	1	5
Phacélia Phacelia Phazelia	1	1	1	3
Avoine Oat Hafer	2	1	1	4
Lin Linseed Leinsaat	1	1	1	3
Radis Radish Radieschen	1	1	1	3
Moutarde Mustard Senfsamen	1	1	2	3
Féverole Field beans Ackerbohnen	2	6	1	5
Trèfle Clover Klee	1	1	1	3

Calibration Charts

An example detailing how to use the calibration chart.

Setting Chart for Wheat.

Note: Row spacing is 16 for both 3/4 metre Unidrill

Working width. No of rows. Row spacing

Working width	No of rows	Row spacing
2,50	17	16
	21	12
3	18	17
	19	16
	21	14
3,50	23	15
	29	12
4	24	17
	27	15
	29	14
	33	12
4,5	29	15,5
	33	14
4,8	33	14,5
5	33	15
6	40	
	44	
	48	
6,66	44	
	48	

Blé / Wheat / Weizen							
cm	12	13	14	15	16	17	
kg/ha							
71	20	22	24	26	28	30	
80	160	23	25	28	30	32	34
90	180	27	29	32	34	35	39
100	200	30	33	35	38	40	43
110	220	33	36	39	42	44	47
120	240	36	39	42	45	48	51
130	260	39	43	46	49	52	54
140	280	42	46	49	52	55	58
150	300	45	49	52	55	58	61
160	320	48	52	55	58	62	64
170	340	51	54	58	61	64	67
180	360	53	57	61	64	67	70
190	380	56	60	63	67	70	73
200	400	58	62	66	69	72	75
210	420	61	65	68	72	75	78
220		63	67	71	74	77	80
230		67	71	75	78	81	83
240		69	73	77	80	83	85
250		71	75	79	82	84	86

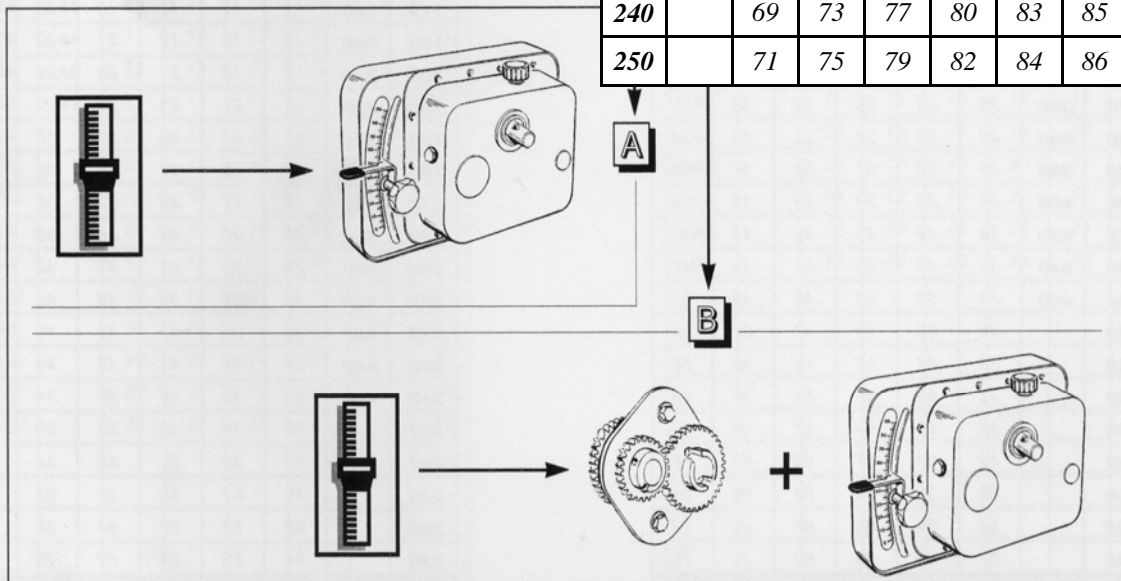

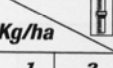

Calibration Charts

Calibration charts for Rape, Barley, Peas and Field Beans.

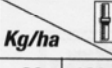
Colza / Rape / Raps							
		12	13	14	15	16	17
							
1	2	4	4	5	5	5	5
1,5	3	6	6	7	7	7	8
2	4	7	8	9	9	10	11
2,5	5	9	10	11	12	12	13
3	6	11	12	13	14	15	16
3,5	7	13	14	15	16	18	19
4	8	15	16	18	19	20	22
4,5	9	17	18	20	22	23	25
5	10	19	21	22	24	26	27
5,5	11	21	23	25	27	29	30
6	12	23	25	27	29	31	33
7	14	27	30	32	34	37	39
8	16	31	34	37	39	42	44
9	18	35	38	41	44	47	50
10	20	39	43	46	49	52	54
11		43	47	50	53	56	58
12		47	50	54	57	59	62
13		50	54	57	60	62	64
14		54	57	60	63	65	66
15		57	60	63	65	66	
A	B						

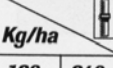

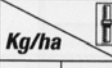

Orge / Barley / Gerste							
		12	13	14	15	16	17
							
90	180	33	36	38	41	44	47
95	190	35	38	41	44	47	49
100	200	36	40	43	46	49	52
105	210	38	42	45	48	51	54
110	220	40	44	47	50	54	57
120	240	44	48	51	55	58	61
130	260	48	52	55	59	62	65
140	280	51	55	59	63	66	69
150	300	55	59	63	66	70	73
160	320	58	62	66	70	73	76
170	340	61	65	69	73	76	80
180	360	64	68	72	76	79	83
190	380	67	71	75	79	82	86
200		70	74	78	82	85	89
210		72	77	81	85	88	
220		75	79	83	87		
240		79	84	88			
250		82	86				
160		84	89				
280		88					
A	B						

Pois / Peas / Erbsen							
		12	13	14	15	16	17
							
120	240		11	13	16	18	20
130	260	11	13	16	18	21	23
140	280	13	15	19	21	24	26
150	300	16	18	21	24	26	29
160	320	18	21	24	26	29	32
170	340	20	23	26	29	32	35
180	360	22	25	28	32	34	37
190	380	24	28	31	34	37	40
200	400	26	30	33	36	39	42
210	420	28	32	35	39	42	45
220	440	31	34	38	41	44	47
240	480	34	38	42	45	49	52
250		36	40	44	47	51	54
260		38	42	46	49	53	56
280		42	46	50	53	57	60
300		45	49	53	57	60	63
320		49	53	57	60	63	66
340		52	56	60	63	66	69
360		55	59	63	66	69	72
380		57	62	65	69	72	74
A	B						





Féverole / Field beans / Ackerbohnen							
		12	13	14	15	16	17
							
100	200	12	14	15	16	18	19
105	210	13	14	16	17	19	20
110	220	14	15	17	18	20	22
120	240	15	17	19	21	22	24
130	260	17	19	21	23	25	27
140	280	19	21	23	25	27	30
150	300	21	23	25	27	30	32
160	320	22	25	27	30	32	35
170	340	24	27	30	32	35	38
180	360	26	29	32	35	38	41
190	380	28	31	34	37	40	44
200	400	30	33	36	40	43	47
210	420	32	35	39	42	46	49
220	440	34	37	41	45	49	52
240	480	38	42	46	50	54	58
250		40	44	48	52	56	60
260		42	46	51	55	59	63
280		46	51	55	60	64	68
300		50	55	60	64	69	73
320		54	59	64	69	73	77
A	B						





Calibration Charts

Calibration charts for Oats, Mustard, Phacelia and Radish

Avoine / Oat / Hafer							
		12	13	14	15	16	17
		 Kg/ha					
80		40	42	45	48	51	54
85		42	45	48	51	54	57
90	180	44	47	51	54	57	60
95	190	46	50	53	57	60	63
100	200	48	52	56	59	63	66
105	210	51	54	58	62	65	69
110	220	53	57	61	64	68	71
120	240	57	61	65	69	72	76
130	260	61	66	70	73	77	81
140	280	65	70	74	78	82	86
150	300	69	73	78	82	86	90
160	320	72	77	82	86	91	93
170	340	76	81	86	90	93	94
180	360	79	85	90	93	94	88
190	380	83	88	93	94	89	74
200		86	91	94	91	78	47
210		90	94	93	82	55	
							

Moutarde / Mustard / Senfsamen							
		12	13	14	15	16	17
		 Kg/ha					
2	4	8	9	9	10	10	11
2,5	5	9	10	11	11	12	13
3	6	11	12	12	13	14	15
3,5	7	12	13	14	15	16	17
4	8	13	14	15	17	18	19
4,5	9	15	16	17	18	20	21
5	10	16	18	19	20	22	23
6	12	18	19	21	22	24	26
7	14	21	23	24	26	28	30
8	16	24	26	28	30	32	34
9	18	27	29	32	34	36	38
10	20	30	32	35	37	39	42
11		33	35	38	41	43	46
12		36	38	41	44	47	51
13		38	41	45	48	52	55
							

Phacélie / Phacelia / Phazelia							
		12	13	14	15	16	17
		 Kg/ha					
16	32	8	9	10	10	11	11
18	36	9	10	11	11	12	12
20	40	10	11	12	12	13	14
22	44	11	12	13	13	14	15
24	48	12	13	13	14	15	16
26	52	13	14	14	15	16	17
28		13	14	15	16	17	18
30		14	15	16	17	18	19
32		15	16	17	18	19	21
34		16	17	18	19	21	22
38		17	19	20	21	23	24
40		18	20	21	23	24	25
42		19	21	22	24	25	27
45		20	22	24	25	27	29
48		22	23	25	27	29	30
50		23	24	26	28	30	32
							

Radis / Radish / Radieschen							
		12	13	14	15	16	17
		 Kg/ha					
30	60	9	10	11	11	12	13
34	68	10	11	12	13	14	15
36	72	11	12	13	14	15	16
38		12	13	14	15	16	17
42		13	14	15	16	18	19
45		14	15	16	17	19	20
48		15	16	17	19	20	21
50		15	17	18	20	21	22
53		16	18	19	21	22	24
56		17	19	21	22	24	25
60		19	20	22	24	26	27
							

Notes

Warranty

In this warranty Moore Uni-Drill is referred to as the Company.

1. Subject to the provisions of this warranty the Company Warrants each new machine sold by it to be sold free from any defect in material or workmanship.
2. If the machine or part there of supplied by the Company is not in accordance with the warranty given in clause 1 the Company will at its option;-
 - (a) Make good the machine at the Company's expense, or
 - (b) make an allowance to the purchaser against the purchase price, or replace the machine as soon as reasonably practicable.
3. This warranty shall not oblige the Company to make any repayment in respect of loss of profit or other consequential loss or contingent liability of the purchaser alleged to arise from any defect in the machine or impose any liability on the company other than that contained in clause 2.
4. Any claim under this warranty must be notified to the company in writing specifying the matters complained of within 12 months from the date of receipt by the purchaser or his/her nominee of the machine.
5. Any claim under this warranty must be made by the original purchaser of the machine and is not assignable to any third party.
6. If the purchaser hires out the machine to any third party the warranty shall apply only to matters notified to the Company within 90 days of the date of delivery and clause 4 shall be read as if the period of 90 days were substituted for the period of 12 months.
7. **The warranty will cease to apply if:-**
 - (a) **any parts not made, supplied or approved in writing by the Company are fitted to the machine, or**
 - (b) **any repair is carried out to the machine other than by or with the express written approval of the Company, or**
 - (c) **any alterations not expressly authorised by the Company in writing are made to the machine, or**
 - (d) **the machine is damaged by accident, or**
 - (e) **the machine is abused or overloaded or used for a purpose or load beyond its design capabilities.**
8. Any dispute as to whether the goods are sold free from any defect in workmanship or materials shall be referred to a single arbitrator to be agreed between the company and the buyer.



In accordance with the program of continuous Development at **MOORE UNIDRILL Ltd**, alterations in the specification may be made at any time without notice.

Therefore **MOORE UNIDRILL Ltd** will not accept responsibility for any discrepancies which may occur between the specification of machines thereof contained in this publication.

MOORE UNIDRILL LTD
33 KIRK ROAD, BALLYMONEY
Co. ANTRIM N.IRELAND BT53 6PP

TEL: (++44) 028276 64444
FAX: (++44) 028276 65696
Email: info@moore-unidrill.com
Website: www.moore-unidrill.com