

# Foreword

Please read and observe these instructions very carefully before you proceed to operate the seed drill. In this way you will avoid accidents, reduce repair costs and downtimes and increase the reliability and service life of your seed drill. Pay particular attention to the safety instructions! Moore Unidrill Ltd cannot assume any liability for damage or malfunctions caused by a failure to observe the instructions contained in this operating manual.

The purpose of this operating manual is to enable you to familiarize your self with the working of your seed drill and to make full use of the many possibilities of application which it affords. The manual will first of all explain the seed drill in general and then proceed to describe the special features of the different models. The chapters entitled "Additional Accessories", "Care and Maintenance" and "Troubleshooting" apply to **all** seed drill models.

The terms "right", "left", "front" and "back" are used here for when sitting in the tractor seat looking forward.

This operating manual must be read and used by all persons who are required to carry out work either on or with the seed drill, e.g.,

- Operation
- Maintenance
- Transporting.

Enclosed with this operating manual is a registration card. Once you have familiarised yourself with the drills operation, please return the registration card to Moore Unidrill Ltd. This will confirm your acquisition of the seed drill. The period of guarantee commences on the date of of delivery. Moore Unidrill Ltd reserve the right to make changes to the illustrations and data on specifications and weights contained in this operating manual if we make any improvements to the seed drills. This instruction manual is to be read in conjunction with the Kverneland Accord Operating manual, also supplied.

## Seed drill identification.

Once you have accepted delivery of the seed drill, please enter the following data:

Serial No.: .....

Seed drill model: .....

Working width: .....

Number of coulters: .....

P.T.O. shaft speed: .....

Accessories: .....

.....

.....

Date of issue of Operating Manual: March 2011  
 MOORE UNIDRILL LTD  
 33,KIRK ROAD  
 BALLYMONEY,  
 Co.ANTRIM,  
 NORTHERN IRELAND BT53 6PP  
 Tel. +44(0)28 2766 44444  
[www.moore-unidrill.com](http://www.moore-unidrill.com)  
[sammy@moore-unidrill.com](mailto:sammy@moore-unidrill.com)

## Guarantee Guidelines

1. Our products are guaranteed [or a period of 12 months commencing on the date of delivery to the user. The guarantee does not cover the replacement of parts subject to wear.
2. Guarantee claims must be submitted on special Moore Unidrill Ltd claim forms to Moore Unidrill Ltd product support, at Ballymoney. Claims cannot be considered unless the claim form has been completed in full and submitted no later than 3 months after occurrence of the damage or defect giving rise to the guarantee claim.
3. Parts replaced under the terms of the guarantee will first of all be charged to the customer pending a decision by Moore Unidrill Ltd Product support Department as to whether or not the guarantee claim is justified. Parts replaced under the guarantee must therefore be returned to our works for inspection.
4. Once the guarantee claim has been acknowledged, a credit note will be issued on the basis of prices ruling on the date on which the guarantee claim was received and in accordance with Moore Unidrill Ltd. general terms of delivery and payment

## Safety

### Proper use

### Operational safety

- No liability for consequential damage

### Road safety

### Accident prevention

- When coupling seed drill to tractor
- When using p.t.o. shaft
- When using the hydraulic system
- When operating the seed drill

### Care and maintenance

Please read all safety instructions contained in this operating manual with the utmost care and also observe all warning signs attached to the seed drill. These warning signs must be kept in a legible condition and must be replaced if missing or damaged. This is especially the case when whole sections are replaced when making repairs. Warning signs are available from your dealer or importer.

Follow these instructions to prevent accidents. These instructions must also be made available to all other users. You are advised to refrain from any working methods which may be hazardous.

## Proper use

MOORE seed drills are based on state-of-the-art technology and are manufactured in accordance with recognized safety requirements. Nevertheless, the use of these seed drills does not preclude the risk of injury to the user or third parties and/or the risk of damage to the seed drill itself or to other materials or items of equipment.

Always make sure that the seed drill is in a technically perfect condition and that it is used properly and for its intended purpose and entirely in accordance with the instructions given in this manual! Any malfunctions or defects which might affect the safe operation of the seed drill must be immediately eliminated.

The seed drill may be used, maintained and repaired only by persons who are familiar with its working and have been made fully conversant with the risks involved.

OEM replacement parts and accessories from Moore Unidrill have been specially designed for use with Moore Unidrill drills. Any replacement parts and accessories not supplied by Moore Unidrill have not been tested or approved by us. The installation and/or the use of non-Moore products may under certain circumstances have a negative influence on the given design features of your seed drill and may therefore adversely affect its safe and reliable operation and your safety. Moore Unidrill cannot be held liable for damage or injury caused by the use of non-OEM replacement parts or accessories.

Moore Unidrill seed drills are intended for seeding (sowing). Any uses other than those for which the seed drills are intended, such as transportation, will automatically exempt or the supplier from its/his Moore Unidrill liability in respect of ensuing damage. Such cases of improper use will therefore be entirely at the user's own risk.

All relevant accident prevention regulations, as well as other generally acknowledged safety and health regulations and road traffic regulations, must be strictly observed.

Improper use also comprises failure to observe the instructions given in this operating manual and the manufacturer's maintenance and servicing requirements.

## Operational safety

The seed drill must not be put into operation until the user has been given proper initial instruction either by the dealer or by one of Moore Unidrill Ltd representatives or employees. Completed registration cards are to be sent to Moore Unidrill Ltd

The seed drill may be used only if all safety devices, e.g. detachable guards, are fitted and in proper working order.

Nuts and bolts should be checked at regular intervals and tightened if necessary.

Tyre pressures must also be checked regularly.

In the event of a malfunction, immediately cease operation and secure the seed drill in its stationary position. Malfunctions must be eliminated immediately.

## **No liability for consequential damage**

Even though your Moore Unidrill seed drill has been manufactured with the utmost care and you are using it properly, fluctuations and interruptions in seed delivery may still occur, the possible causes being:

- differences in composition of the seed or fertilizer (grain size, density, shape, dressing, treatment)
- clogging or bridging (e.g. through foreign bodies, glumaceous seed, sticky dressing agents, moist fertilizers)
- worn parts (e.g. metering device, V-belt)
- damage through external influences
- incorrect drive speeds and forward speeds
- incorrect setting of seed drill (wrongly mounted, failure to observe calibration charts)
- incorrect connection or operation of the electronic seed drill drive or an error in the tractor's electric installation.

It is therefore advisable, both before and during use, to check that the seed drill is functioning properly and delivering the seed with the required accuracy. Such deviations in the delivery rate are only partially detectable by the electronic seed drill control and the monitor of the electronic seed drill drive!

Any claims for damages not directly incurred by the seed drill cannot be accepted. By the same token, Moore Unidrill cannot be held liable for any consequential damage resulting from incorrect metering or distribution.

## **Road safety**

Road traffic regulations must be observed when towing the seed drill on roads, paths and other public places. The seed drill must be in a roadworthy condition!

Observe the maximum permissible width for road transport and fit all necessary rear lights, warning signs and guards. Disconnect the electrical supply when fitting.

Fold up the side sections, track markers, etc. and secure them in the transport position. When transporting the seed drill on the road, lock the control valve in the tractor cabin in order to prevent the coulter bar from being opened out accidentally. In addition close the ball valve in the hydraulic hose.

Trip ropes for quick-release couplings must hang loose and must not, when in their lowered position, release the couplings of their own accord.

Observe maximum permissible axle loads, the load-bearing capacity of the tyres and the maximum total weights in order to ensure adequate steering and braking. The behaviour of the tractor is also influenced by attached implements. Take the width and balancing weight of the seed drill into consideration, especially on sharp bends.

No persons may be allowed to ride on the seed drill.



## Accident prevention

Careful heed must be paid not only to the safety instructions contained in this operating manual but also to the accident prevention regulations governing the operation of agricultural machinery. You could injure yourself on those edges of the seed drill which need to be sharp.

### When coupling seed drill to tractor

The work of coupling and uncoupling the seed drill (using the three point linkage) involves a high risk of injury. The following instructions must therefore be carefully observed:

- Secure the tractor in such a way that it cannot roll forwards or backwards.
- Slowly and carefully actuate the three-point power lift system.
- Be extremely careful when working with a three-point linkage. Always be aware of the shearing hazard between the tractor and the seed drill.
- Position the seed drill with its support legs on firm, level ground.

The tractor and the seed drill must be equipped with the same category of three-point linkage.

### When using P.T.O. shaft

See operating instructions for universal joint shaft!

Use only the universal joint shaft which is intended for use with your seed drill and make sure that it is fitted with the prescribed protective equipment (protective tube and funnel-shaped P.T.O. shaft guard must be fitted). Make sure that the tractor engine and the P.T.O. shaft are switched off before proceeding to fit the universal joint shaft.

Make sure that the tubes overlap by the prescribed distance in both transport and operating position and are secured in such a way that they cannot rotate with the shaft.

Be absolutely sure that there is nobody standing in dangerous proximity to the seed drill when you switch on the P.T.O. shaft.

The P.T.O. shaft speed of the tractor must correspond with the maximum permissible rotational speed of the seed drill. The angle of attachment will depend on the type of P.T.O. shaft (see operating instructions for P.T.O. shaft).

Always switch off the P.T.O. shaft if the angle of divergence is excessive or whenever the P.T.O. shaft is not required.

### When using the hydraulic system

Do not connect the hydraulic hoses to the tractor's hydraulic system until you have made sure that the system is at zero pressure on both the tractor and the equipment side.

The hydraulic system generates extremely high pressures. All piping, hoses and connections must therefore be checked regularly for leakage and visible external damage! Use a proper and thorough means of searching for leakage and repair all damage immediately! Spurting hydraulic oil can cause injuries and fires. Call a doctor immediately in the event of injury!

In order to exclude the possibility of incorrect connection, all mating plugs and sockets belonging to the hydraulic connections between the tractor and the seed drill should be marked with matching colours.

### **When operating the seed drill**

Prior to start-up and operation, make sure that nobody is standing in dangerous proximity to the seed drill (especially children).

No persons may ride on the seed drill during operation.

None of the prescribed guards supplied with the seed drill may be removed during operation.

No persons may be allowed to stand within the working area of the pre-emergence markers or the (hydraulically) folding track markers.

### **Care and maintenance**

Observe all generally or specifically prescribed intervals for maintenance checks and inspections which have to be carried out regularly.

Before carrying out any care or maintenance work, always de-pressurize the hydraulic system and switch off the P.T.O shaft and the tractor engine. Uncouple the seed drill from the tractor.

Make sure, prior to carrying out any care or maintenance work, that the seed drill is standing on firm, level ground and cannot roll away or tip over (support legs). Do not make use of any parts of the seed drill as steps or footholds. Use a proper and safe means of gaining access to the parts of the seed drill which require care or maintenance.

Prior to washing the seed drill with water or a steam jet (high-pressure cleaner) or with any other suitable cleansing agents, use protective coverings to seal off all openings which, for safety or functional reasons, must be protected against ingress of water, steam or cleansing agent. These are, for example, the bearings, the fan, the signal distributor and the electric plug type connectors. These protective coverings must be completely removed after the washing operation.

All hydraulic lines must now be checked for leakage, looseness, abrasion and damage. All defects and damage must be immediately rectified!

Prior to carrying out maintenance and repair work on the electrical system, disconnect it from the power supply.

When carrying out electric welding on the tractor-mounted seed drill, disconnect the cables from the tractor's generator and battery.

All screw connections which had been slackened or unscrewed for maintenance and repair purposes must now be refitted and properly tightened. All screw connections which had been slackened or unscrewed for maintenance and repair purposes must now be refitted and properly tightened.

## Description and technical detail.

The Moore Grassland Unidrill uses a Kverneland Accord DE/S hopper, and full operating details, parts lists, and other CE information is included within the attached instruction books pertaining to that product.

The following description will allow you to familiarize yourself fully with the working of the seed drill.



1. Hopper access steps
2. Hand rail
3. Accord DE/S Hopper
4. A frame cat 1 top link
5. PTO Shaft
6. Parking Stand in work position
7. Rear packer depth adjustment arrangement and pin.
8. Accord Drive Wheel
9. Seedbox A frame
10. Additional ballast weights
11. Cat 3 Headstock
12. Trailed Rubber suspension arms
13. Seeding coultter disc assemblyGuttler packer roller
14. Guttler Roller

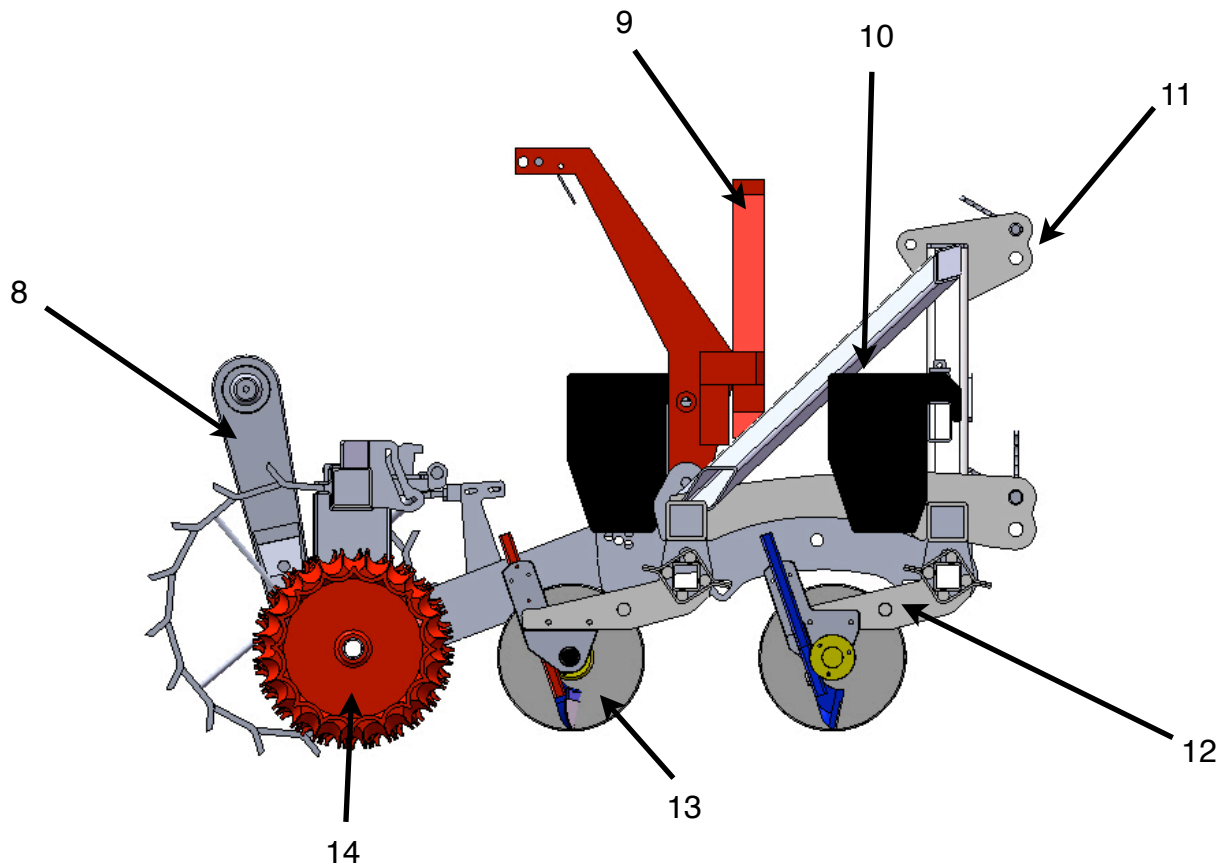

- Cat 3 linkage mounting.
- 32 rows at 90mm close spacing disc seed coulters.
- 700 litre Kverneland ACCORD hopper
- 1000rpm PTO fan drive (Hydraulic Optional)
- Total weight is 2400kg and with standard 20 x 30 kg ballast it is approx 3000kgs.
- Optional additional ballast, in 35kg sections can also take this up to a maximum of 3700kgs
- 3 metre transport width , with a drive wheel , which is quickly set inside frame for road transport, working width is 2.9 metres
- Heavy Duty 100mm x 100mm x 10mm Powder coated chassis.
- Low maintenance trailing arm rubber suspension, offset to achieve close row spacing.
- Proven MOORE UNIDRILL sowing disc/coulter arrangement 370mm x 5 mm boron discs
- LONG LIFE Tungsten carbide tipped coulters
- NKE tapered roller bearings. QUADRUPLE sealed on the disc face, and double sealed on the outer face.
- Folding rear filling safety step with safety rail
- LED Road lights
- Full width GUTTLE GREENMASTER self cleaning packer roller.

# Setting and using the seed drill

## Road transport

Fit warning signs and the necessary lighting and guards for road transport.

Make sure the seed hopper is empty before you proceed to transport your seed drill along the road.

The maximum speed at which the seed drill may be transported on the road is 25km/h

Retract the Seeding drive wheel and lock it in position.

Fold up the hopper access steps.

An adequate front tractor ballast should be used, to ensure safe transportation at all times.

## Prior to sowing

### Coupling the drill to tractor

When coupling the seed drill to tractor, make sure there are no persons standing between the tractor and the seed drill.



Set the tractor's draft links in such a way that the seed drill can swing sideways only very slightly, and so that each arm can float independently, and allow the rear packer to control the seeding depth independently of the tractor. After hitching on to the lower links, raise the drill and fold up the parking stands, slide them inside the chassis and secure with the lynch pins provided.

Lower the lower link arms and then attach the top link.

The top link should be positioned as high as possible on the tractor and as low as possible on the headstock so that the seed drill is as parallel as possible with the ground when raised.

On level ground, Set the top link length so that the **swingometer** on the side of the drill points to the middle position, to indicate that the chassis is level, so that both front and rear discs will operate at the same depth.

Make sure the tractor engine and PTO are switched off before you proceed to fit the universal joint shaft.

Observe the special operating instructions for the universal joint shaft.

In the case of some tractor models, the universal joint shaft must be cut to the correct length. This must be done in such a way that the power transmission is not adversely affected. After shortening



the shaft, cut the PTO drive shaft guard to size at both ends and then de-burr, clean and grease the protective tubes and the special section tubes.

After it has been adapted fit the universal joint shaft.

The PTO shaft speed of the tractor must correspond with the maximum permissible rotational speed of the seed drill.

In the field pull out the seed drive wheel and secure with pins provided in working position. An adjustable stop can be used to set the downward limit of the drive wheel

When unhitching the drill, put the depth control pins on the packer roller into their lowest position, or shallowest working position so that the packer is carrying the weight of the drill. Set the drill down, and uncouple the top link first, then raise the drill, with the full weight on the rear packer, and at this point, and at this point only, pull out the parking stands, so that the hinge is just proud of the chassis, unfold them, and gently lower the drill onto the stands, making sure the hinge mechanism has engaged properly on both sides, and until they have taken the remaining weight, at which point, uncouple the lower links. **FAILURE TO FOLLOW THIS PROCEDURE WILL CAUSE DAMAGE TO THE HINGE MECHANISM ON THE PARKING STANDS.**

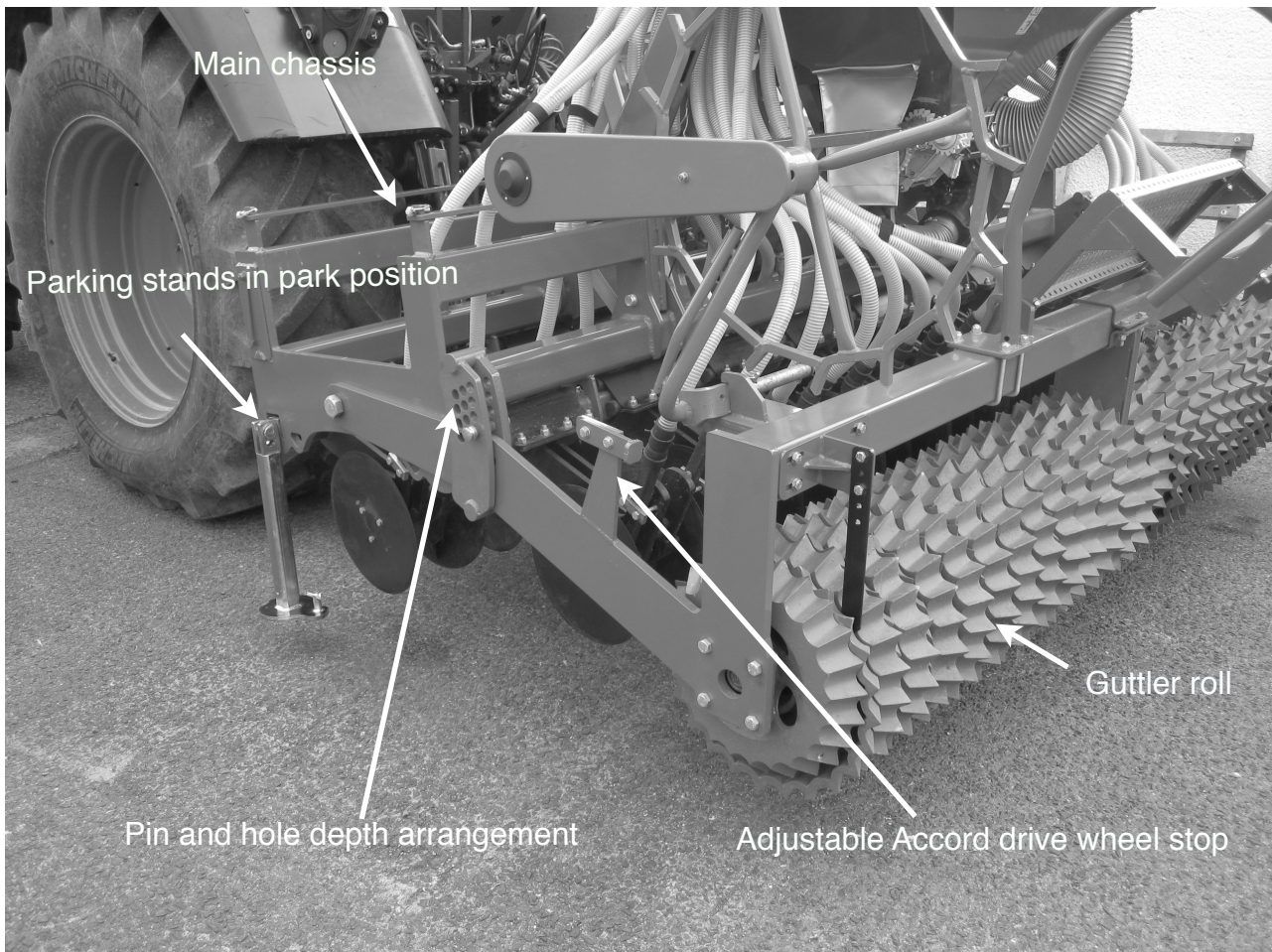

### Setting the sowing depth

The sowing depth can be adapted to the soil conditions by adjusting the coulter pressure.

This is done by adjusting the pin and hole arrangement for raising/lowering the rear Guttler packer roll height in relation to the main chassis. The rear packer acts as a depth stop, and can increase and decrease the amount of pressure on the rubber units.

By keeping the distance between ground and main chassis greater, using the lowest pin holes, then less weight is transferred onto the rubber suspension, and so sowing depth is minimised. But by allowing the main chassis height to come closer to the ground, using the highest holes, then more of the frame weight is allowed to load the rubber suspension, and greater sowing depth is achieved.

In normal circumstances, in good moist conditions, very few of the removable ballast weights are required to achieve grass and small seeding depths, and so these 35kg weights, can be added and removed as required. Please observe HSE manual handling guidelines. Additional weight can be transferred from the Guttler roller, (approx 850kg) by locking the Guttler roller chassis/frame to the main chassis frame. This prevents the Guttler roller from fully floating, and the weight is then used to aid disc penetration. This is done by removing the depth pins on each side, placing 2 block of wood or concrete blocks under the roller, at each end and lowering the complete roller followed by chassis to the desired position, and placing the depth pins on each side into the long slots provided on the guttler chassis/frame, which will line up with the relevant pin and hole depth arrangement. It is possible to get a reasonable position with a balance of weight transfer to disc coulters and also still achieve some packing behind the disc units.

Ballast weights, 750 kg standard, with 750 kg optional, in 35 kg sections can be put on the chassis, so long as it is balanced on each side.....ie if you add 35 kg on one side of the chassis, you must do so on the other side.

When the desired seeding depth is achieved, check that the front and rear coulters are sowing at the same depth, by re-adjusting the top link again, and keeping the swingometer in the central and therefore level position.

### **Calibration and sowing operation.**

Please refer to the Kverneland Accord manual.

## **Care and Maintenance**

All maintenance should be carried out with machine unhitched, with packer roller on lowest pin position, the top link unattached, and both front stands in park position. There is no need ever to get underneath the machine whilst mounted on the tractor. All maintenance and checks can be achieved whilst in the park position. In the highly unlikely event of coulter blockage, this can be relieved, by un doing the corbin clips which attach the flexible seed pipes on top of the tungsten seed tube coulters, and relieving the blockage with a long screw driver or piece of stiff wire from above. When removing articles for service, please observe HSE manual handling guidelines. Common service component weights are listed in the full spare parts list included later in this operating manual.

### **Guttler roller**

The Guttler roller is self cleaning except at each end, were the hardox scrapers work to clean the back to back 50cm rolls. Scrapers should be adjusted and replaced as necessary.

Guttler roll main bearings (1 on each end, and 2 back to back in the middle) should be greased every 20 hours of work, and before each seasons storage.

## Nuts and bolts

All nuts and bolts should be checked regularly. When working in stoney or trashy conditions it will be necessary to check all nuts and bolts daily, particularly the seed tube coulters and disc bolts.

## Bearings

**IMPORTANT: REGULAR CHECKING OF THE BEARINGS WILL ENSURE TROUBLE FREE USE, ESPECIALLY DURING THE FIRST 100 HA. OF USE.**

1" NKE tapered roller bearings are fitted to the disc hubs on the drill. With the drill in the parked position it is easy to check for movement in the bearings. If there is no lateral movement of the disc coulters and they turn freely, the bearing is properly adjusted. If there is lateral movement, that is, if the discs can be moved slightly sideways, then adjust the bearing tension as follows. Remove the dust cover and use a 3/4" socket on the lock nut to tighten up the two taper roller bearings so that they can just turn freely.

**Always replace the locknut and cover if you have to replace a bearing !**

## Seed tube coulters adjustment

Check the position of the seed tube coulters in relation to the disc coulters daily.

For most seeding conditions and as a general rule the tip F of the seed tube coulters should be set so that it is approximately 12mm above the outer edge of the disc.

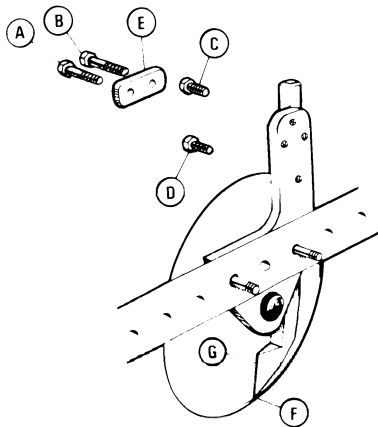

The leading edge of the seed coulters should be set parallel to the disc and just touching it. This can be achieved by means of the retaining bolts A and B and the adjusting screws C and D. If the tip, F, of the seed coulters is out from the disc, this can be corrected by tightening bolt A (front bolt) more than bolt B, while the top, G, of the seed coulters can be brought in towards the disc by tightening Bolt B (rear bolt) more than Bolt A.

Some discs, may be slightly distorted, but when in work the side force of the soil on the disc will keep it in contact with the seed coulters. A certain amount of bedding in and wear takes place between the disc and the seed coulters and it may become necessary to adjust screws C and D to position the seed coulters close to the disc

## Spare Parts

### Disc unit part one (above)

A & B	140032	m10 x 70 bolt
C & D	140037	m10 x 20 bolt
E	10017	seed tube retaining plate
G	20005	370mm x 5mm disc



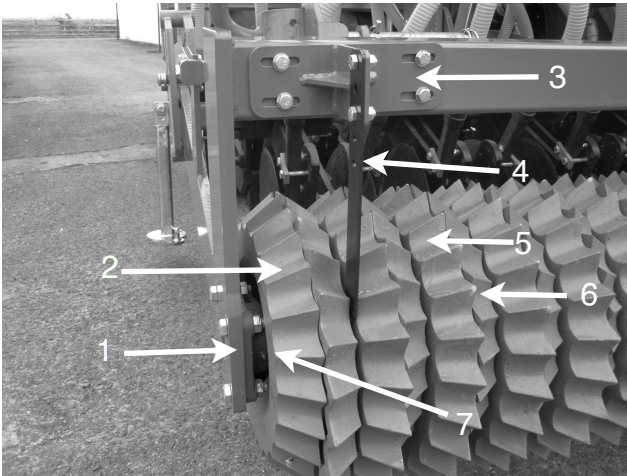

**Guttler roller**

- 1. 75517000 ucf 40mm bearing
- 2. 75408000 45cm special end guttler
- 3. GUT2 guttler scraper holder
- 4. GUT3 guttler hardox scraper
- 5. 75407000 50cm guttler
- 6. 75406000 45cm guttler
- 7. 70403005 1472mm shaft to fit 40mm

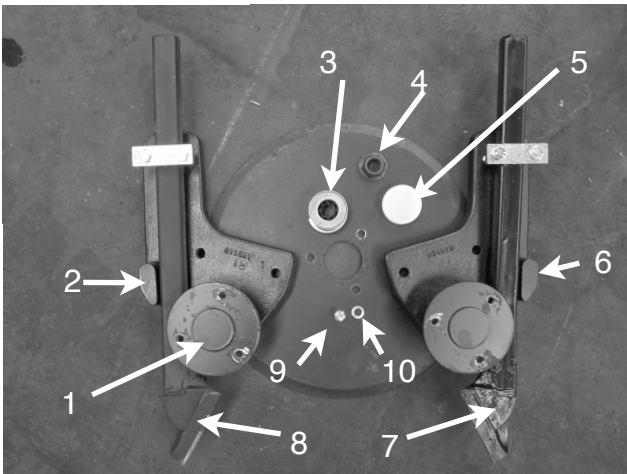

**Disc unit part 2**

- 1. 10258 nke disc hub
- 2. 205-12rh disc bracket right hand
- 3. 660001 1" nke bearing
- 4. 140143 3/4" unfl locknut
- 5. 560004 dust cap
- 6. 206-12lh disc bracket left hand
- 7. 20088LH 30 grass tungs tip coulter left
- 8. 20089RH 30 grass tungs tip coulter right
- 9. 140055 3/8" x 3/4" unfl bolt
- 10. 140039 M10 split washer

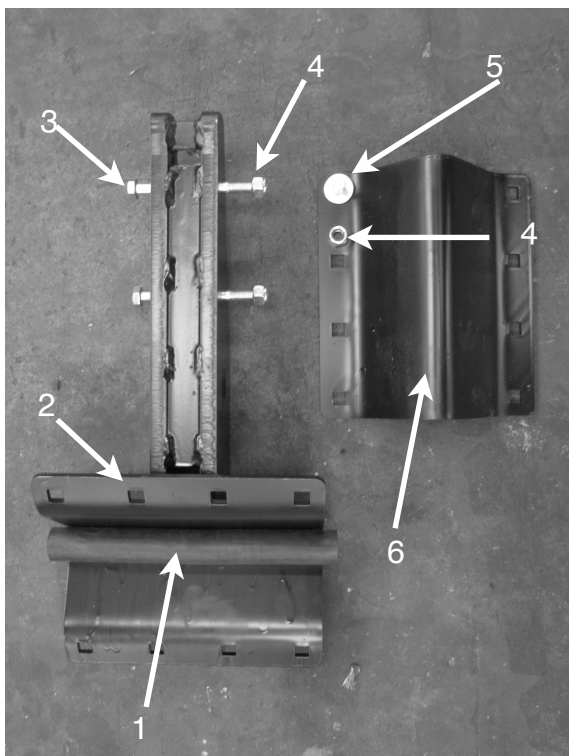

**Suspension unit**

- 1. RC01 rubber sausage
- 2. HUT1001 suspension unit lower arm
- 3. 140022 m12 x 120 bolt
- 4. 140030 m12 nyloc
- 5. 140028 m12 x 35 cup head
- 6. HUT1002 suspension unit bracket upper

**Complete parts list total including weights of common serviceable components.**

	<b>Material</b>		
	<b>Description</b>		
206-12LH / 205-12RH	Disc Bracket Left hand / Right Hand		1
660001	Bearing		1
10258	nke Hub		1
560004	Dust cap		1
140143	3/4 unf locknut		1
<b>201 27 lh / 201 58 rh</b>	<b>Disc bearing replacement unit</b>		<b>1</b>
200005	370mm x 5mm Disc		1
20088LH / 20089RH	30mm coultter Tungsten Tip LH / RH		1
140055	3/8 x 3/4 unf bolt		3
140039	m10 split washer		3
140037	m10 x 20 bolt		2
140032	m10 x 70 bolt		2
10017	seedtube retaining plate		1
<b>20159LH / 20160RH</b>	<b>DISCS UNITS COMPLETE LH / RH</b>	<b>14KG</b>	<b>1</b>
HUT1001	Suspension unit lower arm		1
HUT1002	suspension arm bracket upper		1
RC01	Rubber sausage		4
140028	m12 x 35 cup head bolt		8
140030	m12 nylocs		10
140022	m12 x 120 bolt		2
<b>HUT1003</b>	<b>SUSPENSION UNIT COMPLETE</b>	<b>15KG</b>	
GD1001	Chassis		1
HUT1005	Top link pin CAT 3		1
HUT1006	Bottom link pin CAT 3		2
P122	Top link pins cat 2 25.4 x 110		2
HUT1004 LH/RH	Parking legs LH / RH	11KG	2
P385	P385 Linch pin 7/16"		15
<b>GD1001C</b>	<b>CHASSIS COMPLETE</b>		
LA20612	Lights		2
8JA001918001	7 pin plug		1
HUT1007	light mounting brackets		2
140096	m10 x 35		2
140041	m10 nyloc		2
140098	m10 washer		2
<b>LA20612C</b>	<b>LIGHTS COMPLETE</b>		
<b>MA1001</b>	<b>Paint and finish</b>		
	<b>Zinc Plating</b>		
	<b>Dipping Paint</b>		<b>25</b>
<b>BC1001</b>	<b>Stickers</b>		<b>1</b>
<b>MUDP1001</b>	<b>Instruction Book</b>		<b>1</b>
GUT1	Guttler Packer Roller frame and mounts		1
GUT2	scraper mount plates		2
GUT3	hardox scrapers		2
DWR	drive wheel rest		1
GUT70412100	Guttler Roller Kit includes shaft and bearings		1
75517000	ucf 40mm bearing		4
75408000	45cm special end guttler	14KG	4
75407000	50cm guttler	18KG	26
70406000	45cm guttler	14KG	22
70403005	1472mm shaft to fit 40 mm bearing		2

140010	m16 x 70 bolt	4
140012	m16 x 55 bolt	8
140017	m16 nyloc	12
140065	1 1/4 x 7 1/2 unc bolt 3"	2
140062	1 1/4 nyloc	2
140096	m10 x 35	6
140041	m10 nyloc	14
140098	m10 washer	10
140109	m10 x 120 bolt	8
P111	P111 top link pin cat 1 22 x 78	2
P384	Linch pin 1/4"	2
<b>GUT1C</b>	<b>GUTTLER ROLLER COMPLETE</b>	
HUT1010	Handrail	1
140029	m12 x 55 bolts	4
140030	m12 nylocs	4
140084	m12 washers	8
<b>HUT1010C</b>	<b>HANDRAIL COMPLETE</b>	
HUT1020	step frame	1
SD360750	safe deck 360 x 750	1
SD360750	safe deck 300 x 750	1
140103	m8 x 20 bolts	8
140046	m8 nylocs	8
140042	m8 washers	8
140027	m12 x 30 bolt	2
140030	m12 nyloc	2
140084	m12 washer	4
<b>HUT1020C</b>	<b>REAR STEP COMPLETE</b>	<b>23KG</b>
AC DES_01	ACCORD HOPPER KIT AC DES_01	1
AC489139	Hactaremeter AC489139	1
AC687251	Corbin clip A 26 B	64
AC499970	Hose holder plastic sleeve 32	32
AC499112	A Frame AC499112	1
AC499115	PTO KIT AC499115	1
W300E_1010	PTO SHAFT Walterscheid W300E_1010	1
PTOY1118	PTO Yoke 1118	1
P64	TOP LINK McHugh cat 2	1
P122	p 122 top link pins cat 2 25.4 x 110	2
P385	P385 Linch pin 7/16"	2
ACDB	Drive Belts SPZ 1512	2
	<b>HOPPER COMPLETE</b>	
	<b>ACCORD DRIVE WHEEL</b>	<b>22KG</b>
	<b>Weights 35 KGS x 20</b>	<b>35KG EACH</b>
		<b>20</b>
	OPTIONS	
	<b>Hydraulic Drive in lieu of PTO</b>	
AC497	hyd drive AC497	
AC499866	tachometer AC499866	
AC494253	Hopper low level sensor W lamp	
A200	<b>Weights 35kg each</b>	

# Techniques

The Moore unidrill prepares its own mini seedbed by using an angled disc and seed tube coulter tine. All seeds are planted at a constant depth, The points of the guttler roller slit the ground 305 times per square meter, to give good seed soil contact, however in some conditions another pass with a flat roll is necessary. In all conditions, drilling should be conducted in reasonably straight lines as turning with the drill engaged in the ground, can cause premature bearing failure, and blockages, by pulling disc away from seed tube coulters.

## Direct drilling grass or clover into grass

A healthy field of grass is one of the most valuable assets a livestock farmer can have and direct drilling can help you grow more and better grass at less cost, because there is less labour, machinery and time involved. Other benefits are reduced poaching, a reduction in the number of broad leaved weeds, and the direct drills ability to tackle even quite "difficult" land. The direct drilling of grass into either a short term or mid term sward is a simple enough matter, and even older worn out pastures can be reseeded with the direct drill provided a few precautions are observed .

A one to ten year old sward which is open, presents few problems having had no time to build up any substantial quantity of mat/thatch under the surface. As a rule of thumb, if you can sink the disc into 25mm of 80% clean soil and not root mat and thatch, then you are in business. As with all reseeding, weather plays an important part, but with reasonable moisture and heat the following methods may apply for successful seeding.

### **Method 1 No chemical top up.....clean (weed free) open swards following silage.**

Where a final cut of silage is being taken, and the field is going to grazing, cut low to the ground and direct drill 1/2 to full rate seeds as soon as possible, whilst moisture is retained in the ground, and before the regrowth starts. There should be enough moisture retained in the ground to get the seeds germinated, and provided it doesn't dry out subsequently due to lack of rain, seed should be established before the old sward has fully recovered, and should be grazed with young stock or sheep 2 to 4 weeks later, depending on growing conditions. This grazing keeps the old grass down, stops the old sward choking the new seedlings, and allows light into the newly established grass. This sward should be grazed in 2/3 weekly intervals until the end of the season, never overgrazing as this can cause the new seedlings to be pulled out. Newly established grass often does not normally become apparent until the regrowth following first cut the following season.

Check the Ph of ground prior to seeding and apply lime as necessary to get the ideal pH of 6.5, especially with clover.

A light to medium coat of slurry immediately after seeding (depending on moisture) can be applied providing it contains no effluent or dairy washings.

### **Method 2 No chemical top up.....clean (weed free) open swards following grazing.**

Graze the sward really bare, using a mob stocking rate, harrow/rake/roll the dung pats if necessary, drill the sward, and keep the stock grazing on, until the new shoots are just visible. As above re graze in 2 to 4 weeks time, depending on growth.

Check the Ph of ground prior to seeding and apply lime as necessary to get the ideal pH of 6.5, especially with clover.

A light to medium coat of slurry immediately after seeding (depending on moisture) can be applied providing it contains no effluent or dairy washings.

### **Method 3 Off label herbicide.**

Some customers have reported good results using an off label herbicide.

Metsulfuron Methyl (ally) at 1/3 rate 1.5 - 2.5g/ha. Not only does the chemical kill broad leaved weeds, but also helps suppress the growth of the existing sward for up to 10 days. Leave 10 days before regrazing.

0.8 l/ha of 250 g/l trinexapac-ethyl (moddus) can be used as a growth regulator on silage or grazing land to act as a growth regulator to slow down growth of the existing swards, to allow new grass to get established. This should be applied as soon as regrowth is actively growing.

Check the Ph of ground prior to seeding and apply lime as necessary to get the ideal pH of 6.5, especially with clover.

A light to medium coat of slurry immediately after seeding (depending on moisture) can be applied providing it contains no effluent or dairy washings.

Moore Unidrill cannot be held accountable for off label use of chemicals

### **Method 4 Early Spring drilling**

If the pasture has been badly poached, or there are bad patches due to frost kill, leatherjackets, pests etc, over the winter, new grass seeds should be drilled in just before growth starts in springtime.

Check the Ph of ground prior to seeding and apply lime as necessary to get the ideal pH of 6.5, especially with clover.

A light to medium coat of slurry immediately after seeding (depending on moisture) can be applied providing it contains no effluent or dairy washings.

### **Method 5 Complete sward destruction**

Where the old sward is very weedy, and a complete re seed is required, spray with glyphosate pre or post harvest/grazing to get a total kill off of all vegetation, and direct drill with a new seeds mixture.

**Following grazing** We prefer to graze tight, harrow/rake/roll as necessary after grazing, to disperse dung pats, then drill, and then leave up to a week before spraying off, or certainly before the new seeds germinate. This procedure helps get a good regrowth going to take the chemical, without affecting seed germination.

Check the Ph of ground prior to seeding and apply lime as necessary to get the ideal pH of 6.5, especially with clover.

A light to medium coat of slurry immediately after seeding (depending on moisture) can be applied providing it contains no effluent or dairy washings.

**After silage** We prefer to cut the silage first rather than apply glyphosate pre harvest, at the recommended 5 days, as this prevents any wheelings from the sprayer appearing in subsequent crop, also Glyphosate seems more effective on less volume of grass. By delaying drilling up to a week after cutting, regrowth will have started, and then drill, and delay spray application up to another week, at least before the new seed germinates. This has the effect of giving another weeks regrowth to take the chemical.

The downside of the above techniques is that the grass damaged at the disc row during drilling, is sometimes not adequately controlled by the glyphosate.

Check the Ph of ground prior to seeding and apply lime as necessary to get the ideal pH of 6.5, especially with clover.

A light to medium coat of slurry immediately after seeding (depending on moisture) can be applied providing it contains no effluent or dairy washings.

## **Method 6 Older leys, rough permanent grass or old worn out pastures**

These need to be approached with care. Although Glyphosate deactivates in contact with soil, there is a problem with toxic phenol and acetic acids being released by old decaying sprayed off vegetation, so if there is a thick mat or subsurface mat of roots and fibre, and inevitably the seed is placed near this mat, then germination problems can occur due to localized acidic soil. This is worse in wet anaerobic conditions, before during or after seeding

The problem with direct drilling into sprayed off grass or anything else that has a large root mat is that it is always a big gamble depending on the weather, especially after you have drilled, which is why some people say it's successful and others don't. An analogy is that silage (decaying grass) made in wet conditions is always more acidic when opened.

In a heavy mat situation, waiting for long enough for all the plants to die completely after spraying is the only way to guarantee success with direct drilling on old matted pastures, otherwise you need to either shallow cultivate and roll, to increase the oxygen levels or if you're feeling lucky take a gamble, that the sward wont lie wet after drilling. If you had a thick mat of decaying vegetation and spun bean seeds on the surface and then ploughed them in, you would get the same results. So either spray off in spring and drill in autumn, after a lime application, and probably another lower rate spray, pre drilling, or less production can be lost by spraying off in autumn, applying lime, and drilling in early spring, when a further lower rate spray is usually necessary.

In a lower more marginal mat situation, the application of lime alone can help neutralize the effects of the acidic decomposition, but like all seeding techniques depend on moisture and ground heat. In this situation, we recommend the delayed glyphosate application techniques discussed above, that is to delay glyphosate application until after seeds have been planted, but before they germinate, so that the seeds get maximum exposure to germination, establishment, and deeper rooting before the acidic effects of the decaying plant material come to bear.

A few test sites dug with a spade, will help you decide on the subsurface mat/thatch problems that might be present.

Direct drilling after sprayed off temporary or more open leys isn't usually a problem as the root matt isn't big enough to damage seedlings with its acids and phenols.

**In all the above cases use a vigorous quick establishing grass seed mixture up to 35kg/ha**  
There is no doubt that a blend of 50% perennial Hybrid Tet, 25% Intermediate tet and 25% diploid works best. These are mostly larger seeds with greater energy reserves for coping with adverse situations. Italian ryegrass swards can easily be re-established at the end of their allotted production cycle, by re drilling typically after the third season.

## **Pests**

**Slugs.** Old grass swards can harbour slugs all year round, so it may be advisable, especially on heavy soils, to sow slug pellets along with the seed, or broadcast them at a higher rate where an attack had been observed post drilling.

**Leather jackets (daddy long legs / cut worm/ Tipulidae)** Can be a problem , especially in spring drilling. If a field is thought to be at risk, spray with chlorpyrifos (Spannit or Dursban) on its own or with the glyphosate pre or early post drilling can give 6 weeks control.

**Frit fly (Oscinella frit)** Reseeds sown after early august can be at risk from frit fly attacks. This pest is usually very localised, fields with a past history of attacks, and high risk frit fly years, should be acknowledged. Once again can be controlled by Chlorpyrifos application as above.

## **Sowing into ploughed, pre cultivated and looser seedbeds.**

By running the packer in the highest position, and therefore least pressure on the coulters, seed can be laid on top, or shallow in ploughed or pre cultivated seedbeds.

The guttler press wheels will make a nice job of firming the seed into the soil, without the risk of capping, and no further rolling need take place if required.

## **Sowing into cereal stubble**

It is recommended to run at a slight angle to the existing stubble, approximately 10 to 15 degrees, so that the discs are never constantly running on a row of stubble, and are therefore running in and out of the existing stubble rows.



# Original Instructions

# Moore *System*



## MOORE UNIDRILL LTD

33, KIRK ROAD, BALLYMONEY, Co. ANTRIM, NORTHERN IRELAND. BT53 6PP

PHONE +44 (0) 2827 66 44444 email [sammy@moore-unidrill.com](mailto:sammy@moore-unidrill.com) [www.moore-unidrill.com](http://www.moore-unidrill.com)



## EU DECLARATION OF CONFORMITY

Declaration No. 300G1

**We, the undersigned**

Moore Unidrill Ltd  
33 Kirk Road, Ballymoney  
County Antrim, Northern Ireland.  
BT53 6PP

**Declare under our sole responsibility that the following apparatus:**

Name: MOORE UNI DRILL  
Model:300  
Type:GRASSLAND  
Serial number:

**Is in conformity with the following relevant EC legislation:**

2006/42/EC

**Based on the following harmonised standards:**

EN12100-2:1998., BS EN ISO 14121-1:2007  
EN 982:1996+A1:2008

**And the following Non Harmonised standard**

BS ISO 4254-9:2008

**Risk Analysis was carried out using the following standards:**

BS EN ISO 14121-1:2007

**We, the undersigned, undertake to transmit, in response to a reasoned request by national authorities, relevant information on the machinery by the following method of transmission: Parcel.**

**Name and position of person binding the manufacturer :**

**Signature** \_\_\_\_\_

**Name** Sam Moore

**Function** Managing Director

**Location** Newhill House  
33 Kirk Road, Ballymoney  
County Antrim, Northern Ireland.  
BT53 6PP

**Date of issue** 24/3/11